

The small pumps described on this page are membrane-type. They can be used both as vacuum pumps and compressors. In the latter version they can supply compressed air 100% oil-free up to a maximum 2 bar pressure.

They are composed of:

- An air-cooled single-phase electric motor with protection class IP 00 (assembly execution).
- A pump body made of plastic corrosion-resistant material, complete with fittings at both suction and blowing ports or, upon request, with threaded connections.
- A Viton membrane, fixed to a connecting rod, resistant to wear and corrosion.
- A connecting rod with incorporated long life bearing powered by an eccentric balanced system fitted on the crankshaft.
- An aluminium support, for fastening the pump.

They are available in the versions with single and double head to be used in series or in parallel.

Membrane vacuum mini pumps are very silent ($\leq 50\text{dB(A)}$), they have reduced vibrations and can be installed in any position.

Lubrication-free, they require no maintenance.

Thanks to their minimal overall dimensions and reduced weight, they are particularly indicated for being installed on portable equipment.

They are suited for a discontinuous and non-intense use.

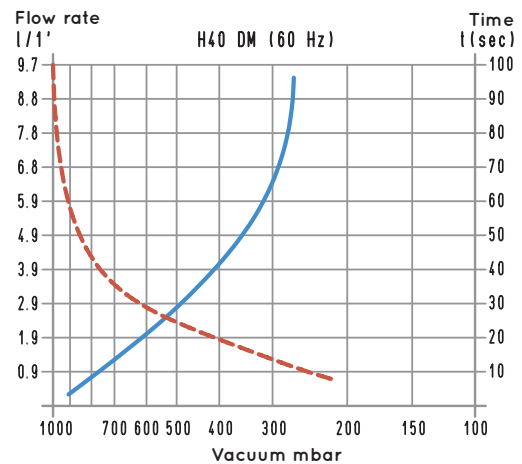
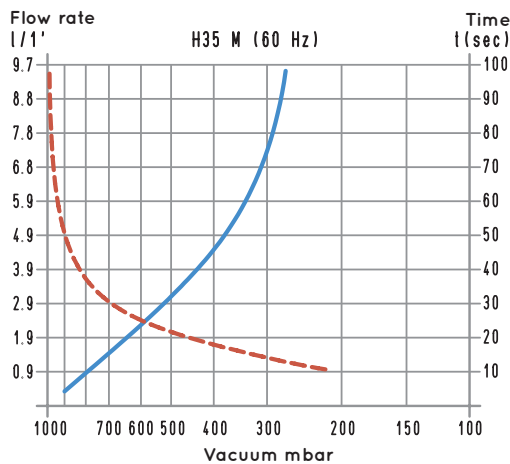
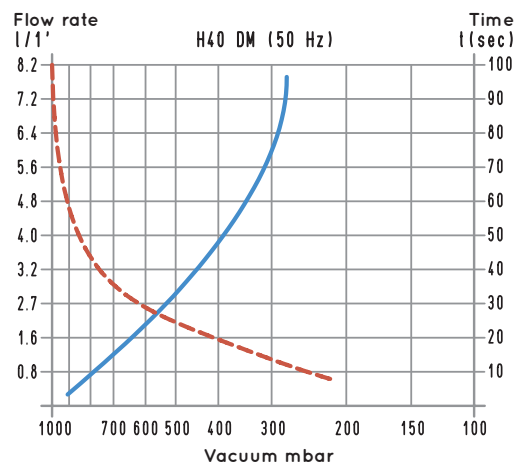
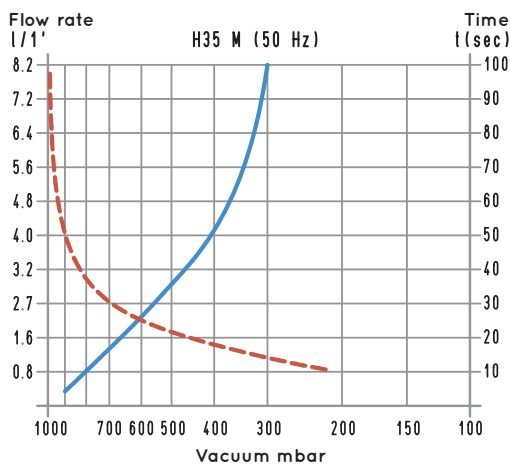
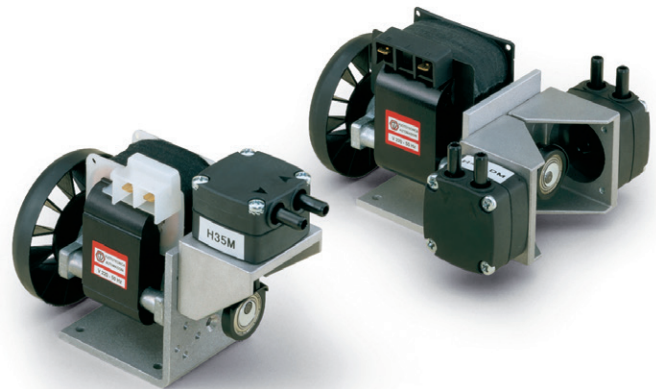

To calculate the emptying time of a volume of V_1 , use the following formula: $t_1 = \frac{t \times V_1}{6}$

- - - Curve relative to the flow rate (referring to a 1013 mbar pressure)
- Curve relative to the emptying time of a 6-litre volume

V_1 : Volume to be emptied (l)
 t_1 : time to be calculated (sec)
 t : time obtained in the table (sec)

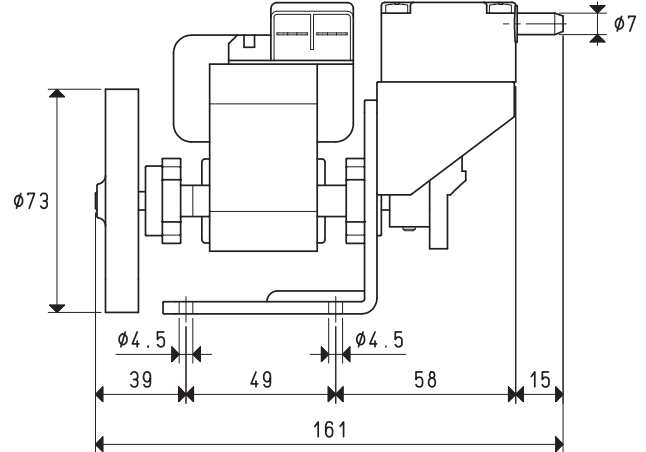
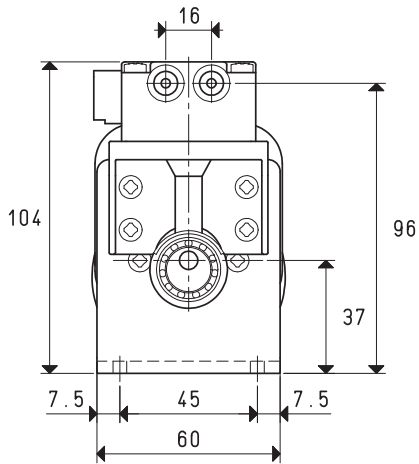
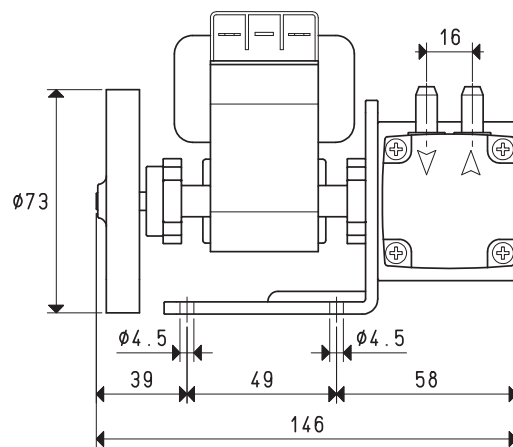
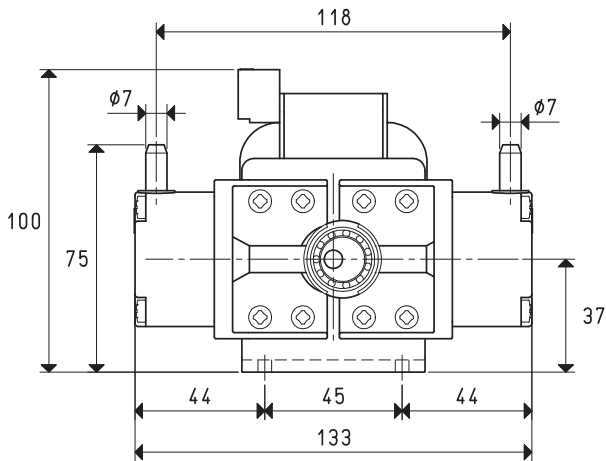
H 35 M

H 40 DM

Item	H35 M		H40 DM	
	50Hz	60Hz	50Hz	60Hz
Frequency	50Hz	60Hz	50Hz	60Hz
Nominal flow rate:				
Connection in series	8	9,5	8	9,5
Parallel connection	=	=	8 + 8	9,5 + 9,5
Final pressure:				
Connection in series	mbar abs.	200	60	
Parallel connection	mbar abs.	=	200	
Maximum pressure	bar	2	2	
Motor performance 1~	volt	110/230 VAC	110/230 VAC	
Motor power 1~	watt	60	72	72
Rotation speed	g/min ⁻¹	2800	3300	3300
Noise level	dB(A)	≤ 50	≤ 50	
Max weight	Kg	1.3	1.6	
Accessories and Parts	H35 M		H40 DM	
Membrane	item	00 H35M 15	00 H40DM 15	
Cover with fittings	item	00 H35M 16	00 H40DM 20	
Cover without fittings	item	00 H35MF 16	00 H40DMF 20	

Add the letter F to the item for a mini pump supplied with G 1/8" threaded suction and blowing connections, without hose fittings. (Example: H40 DM F).