

To calculate the emptying time of a volume of  $V_1$ , use the following formula:  $t_1 = \frac{t \times V_1}{100}$

- Curve relative to the flow rate (referring to the suction pressure)
- - - Curve relative to the flow rate (referring to a 1013 mbar pressure)
- Curve regarding the emptying time of a 100-litre volume

$V_1$ : Volume to be emptied (l)  
 $t_1$ : time to be calculated (sec)  
 $t$ : time obtained in the table (sec)

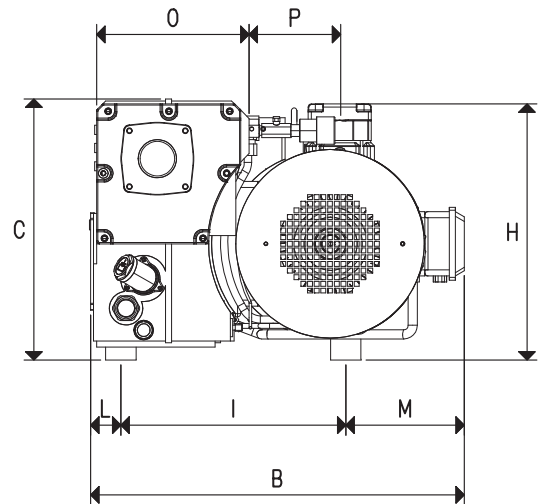
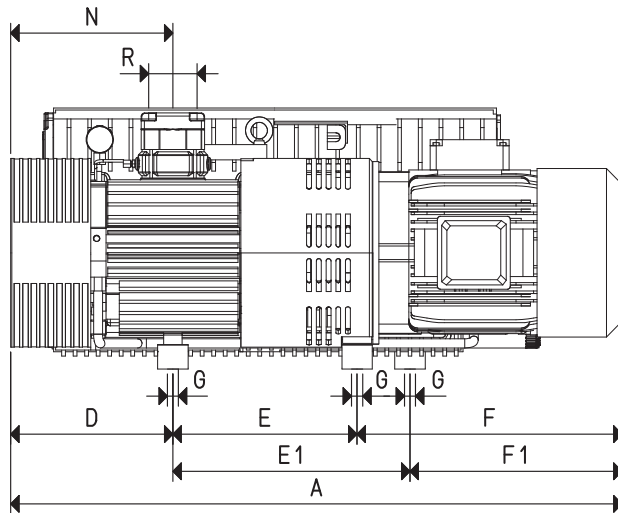

Item		RVP 250		RVP 300	
<b>Frequency</b>		50 Hz	60 Hz	50 Hz	60 Hz
<b>Flow rate</b>	m <sup>3</sup> /h	250	300	300	360
<b>Final pressure</b>	mbar abs.	0.5		0.5	
<b>H<sub>2</sub>O steam quantity permitted</b>	Kg/h	4		4.5	
<b>Motor performance 3~</b>	Volt	400/690 ± 10%	480/830 ± 10%	400/690 ± 10%	480/830 ± 10%
<b>Motor power 3~</b>	Kw	5.5	7.5	7.5	11
<b>Motor protection</b>	IP	55		55	
<b>Rotation speed</b>	g/min <sup>-1</sup>	1450	1740	1450	1740
<b>Motor shape</b>		B5		B5	
<b>Motor size</b>		132		132	
<b>Noise level</b>	dB(A)	74	75	75	76
<b>Max weight</b>	Kg	198.0		212.0	
<b>A</b>		975		1010	
<b>B</b>		579		579	
<b>C</b>		411		411	
<b>D</b>		287		287	
<b>E</b>		303		303	
<b>E1</b>		390		390	
<b>F</b>		385		420	
<b>F1</b>		350		350	
<b>G</b>	∅	M10		M10	
<b>H</b>		421		421	
<b>I</b>		369		369	
<b>L</b>		50		50	
<b>M</b>		185		185	
<b>N</b>		267		267	
<b>O</b>		242		242	
<b>P</b>		150		150	
<b>R</b>	∅ gas	G2"		G2"	
<b>Accessories and Parts</b>		<b>RVP 250</b>		<b>RVP 300</b>	
<b>Oil charge</b>	L	8		8	
<b>Lubricating oil</b>	type	VT OIL 100		VT OIL 100	
<b>Oil filter</b>	item	00 RVP 250 07		00 RVP 300 07	
<b>4 deoiling cartridges</b>	item	00 RVP 250 05		00 RVP 300 05	
<b>3 vanes</b>	item	00 RVP 250 04		00 RVP 300 04	
<b>Sealing kit</b>	item	00 RVP 250 06		00 RVP 300 06	
<b>Check valve</b>	item	00 RVP 250 03		00 RVP 300 03	
<b>Suction filter</b>	item	FC 60		FC 60	
<b>Ballast valve</b>	item	integrated		integrated	