

This series of single-stage vacuum generators, also based on the Venturi principle, can be supplied for optimal supply pressures of 4 or 6 bars. Thanks to their shape, they can be installed directly on the user device and used at the most suitable supply pressure, depending on the desired level of vacuum. They have different capacities and can be used in all gripping systems with vacuum cups, for gripping and handling objects that are not very porous and on equipment with limited capacities. They are available upon request with an SSX 3/8" R high sound suppression silencer, installed on air exhaust R. They are fully made with anodised aluminium, with brass or aluminium ejectors, depending on the items.

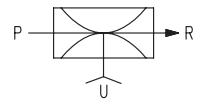
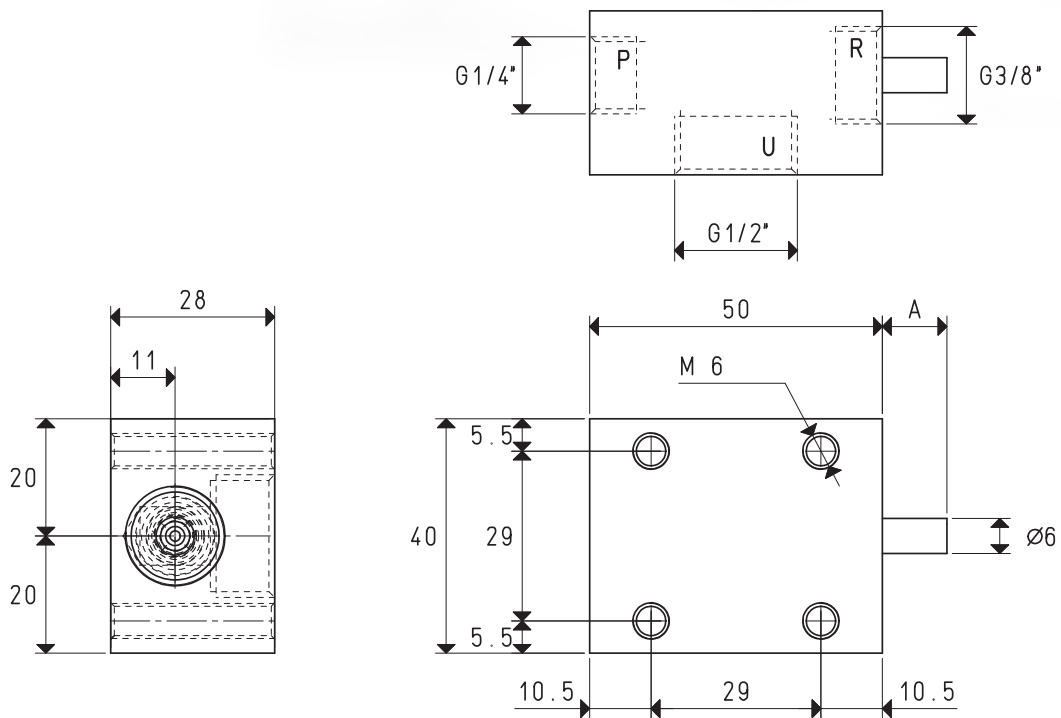

Item	P=COMPRESSED AIR CONNECTION	R=EXHAUST	U=VACUUM CONNECTION								
			VG 03			VG 03 LP			VG 05 LP		
Intake air flow rate	m ³ /h		2.7	2.8	2.9	2.6	2.8	3.0	4.8	4.9	5.0
Maximum level of vacuum	-KPa		55	70	85	43	61	85	40	61	85
Final pressure	mbar abs.		450	300	150	570	390	150	600	390	150
Supply pressure	bar		4	5	6	2	3	4	2	3	4
Optimal supply pressure	bar				6			4			4
Air consumption	NI/s		0.7	0.8	0.9	0.7	0.9	1.2	1.3	1.7	2.2
Operating temperature	°C				-10 / +80			-10 / +80			-10 / +80
Noise level at optimal supply pressure	dB(A)				63			62			71
Weight	g				134			124			124
A	mm				6			9			11

Note: All vacuum values indicated in the table are valid at the normal atmospheric pressure of 1013 mbar and obtained with a constant supply pressure.

Vacuum generator supply must be carried out with non-lubricated compressed air, 5 micron filtration, in accordance with standard ISO 8573-1 class 4.

150110 portata

Air flow rate (NI/s) at different level of vacuum (-KPa) at optimal supply pressure

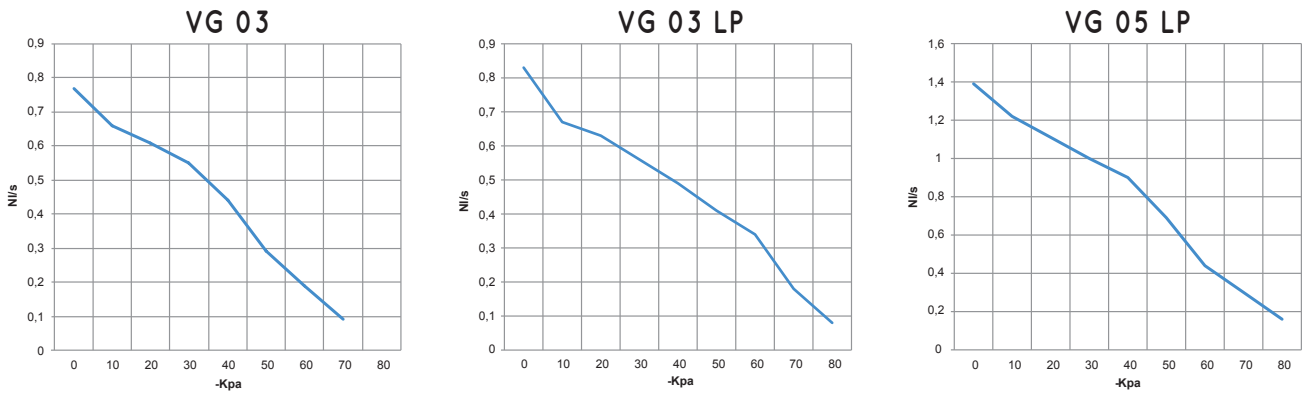

150110 temp

Generator item	Supp. press. bar	Air consumption NI/s	Air flow rate (NI/s) at different levels of vacuums (-KPa) at optimal supply pressure										Max vacuum -KPa
			0	10	20	30	40	50	60	70	80		
VG 03	6.0	0.9	0.80	0.66	0.61	0.55	0.44	0.29	0.19	0.09	--	85	
VG 03 LP	4.0	1.2	0.83	0.67	0.63	0.56	0.49	0.41	0.34	0.18	0.08	85	
VG 05 LP	4.0	2.2	1.39	1.22	1.11	1.00	0.90	0.69	0.44	0.30	0.16	85	

Evacuation rates (ms/l = s/m³) at different levels of vacuums (-KPa) at optimal supply pressure

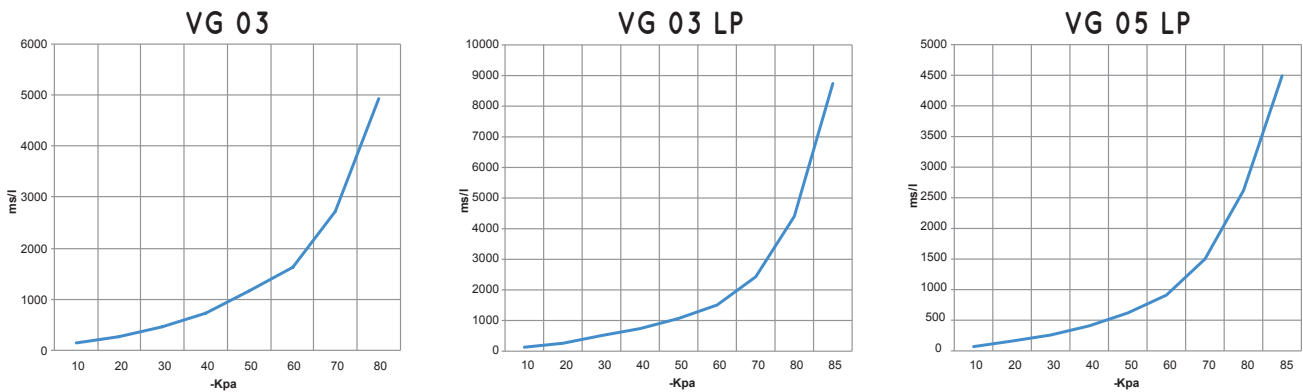

Generator item	Supp. press. bar	Air consumption NI/s	Evacuation rates (ms/l= s/m ³) at different levels of vacuums (-KPa) at optimal supply pressure										Max vacuum -KPa
			10	20	30	40	50	60	70	80	85		
VG 03	6.0	0.9	139	278	472	727	1171	1628	2720	4928	--	85	
VG 03 LP	4.0	1.2	130	260	510	740	1070	1510	2430	4400	8740	85	
VG 05 LP	4.0	2.2	70	160	260	410	620	910	1500	2620	4490	85	

ACCESSORIES UPON REQUEST

Silencer item SSX 3/8" R

