

This single-stage vacuum generator operation is based on the Venturi principle. When the generator is supplied with compressed air in P, the vacuum will be generated at connection U and the supply air with the suctioned air will be discharged in R. During the operating cycle, a chamber inside the generator body will be supplied and, when supply stops in P, the compressed air accumulated in it will be discharged through the U connection, quickly the restoring atmospheric pressure of use.

If when using U, for example, it is connected to a vacuum cup, it will disconnect much faster with this ejector system with respect to the previously described vacuum generators. The optimal air supply pressure is normally 6 bar, but for generators with the letters LP in their item, a pressure lower than 4 bar is sufficient to obtain the best performance. They are fully made with anodised aluminium, with brass or aluminium ejectors, depending on the items.

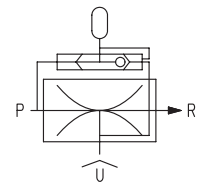
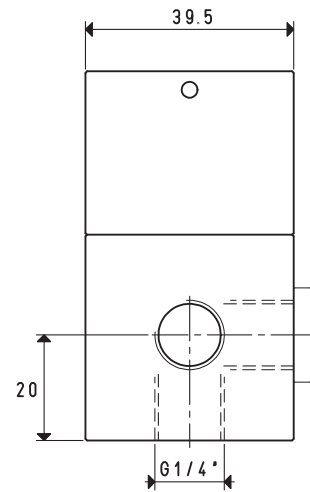
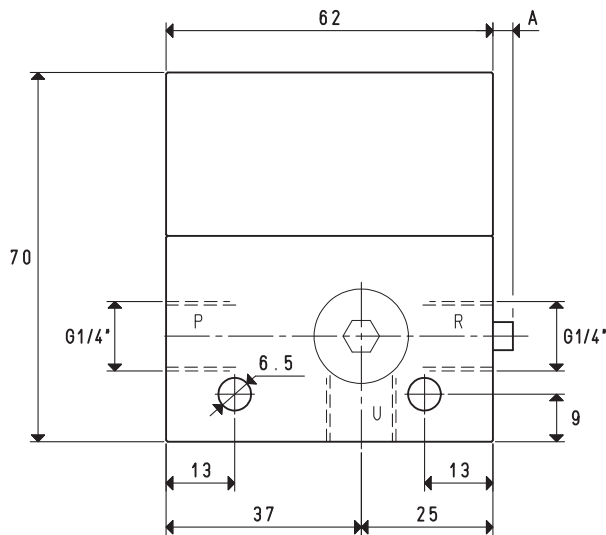
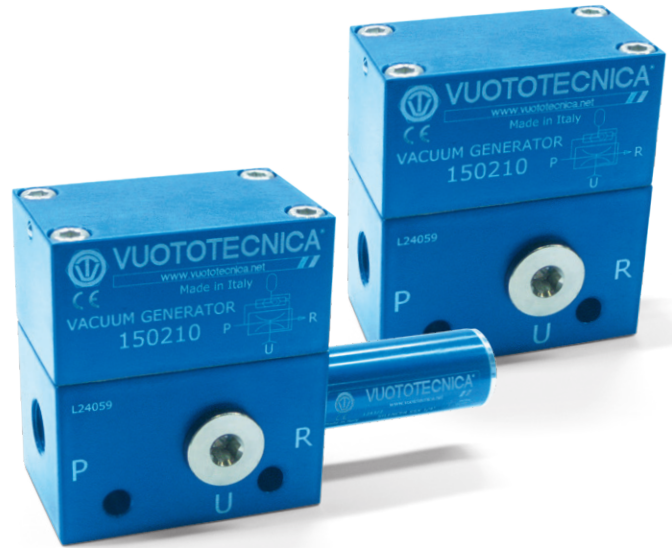

P=COMPRESSED AIR CONNECTION R=EXHAUST U=VACUUM CONNECTION

Item		15 02 10			15 02 10 LP			15 02 15 LP		
Intake air flow rate	m ³ /h	2.7	2.8	2.9	2.6	2.8	3.0	4.8	4.9	5.0
Maximum level of vacuum	-kPa	55	70	85	43	61	85	40	61	85
Final pressure	mbar abs.	450	300	150	570	390	150	600	390	150
Supply pressure	bar	4	5	6	2	3	4	2	3	4
Optimal supply pressure	bar			6			4			4
Air consumption	NI/s	0.7	0.8	0.9	0.7	0.9	1.2	1.3	1.7	2.2
Operating temperature	°C			-20 / +80			-20 / +80			-20 / +80
Noise level at optimal supply pressure	dB(A)			63			63			65
Weight	g			319			320			320
A	mm						3			5
Spare parts		15 02 10			15 02 10 LP			15 02 15 LP		
Sealing kit	item	00 15 500			00 15 500			00 15 500		

Note: All vacuum values indicated in the table are valid at the normal atmospheric pressure of 1013 mbar and obtained with a constant supply pressure.

Vacuum generator supply must be carried out with non-lubricated compressed air, 5 micron filtration, in accordance with standard ISO 8573-1 class 4.

Air flow rate (NI/s) at different level of vacuum (-KPa) at optimal supply pressure

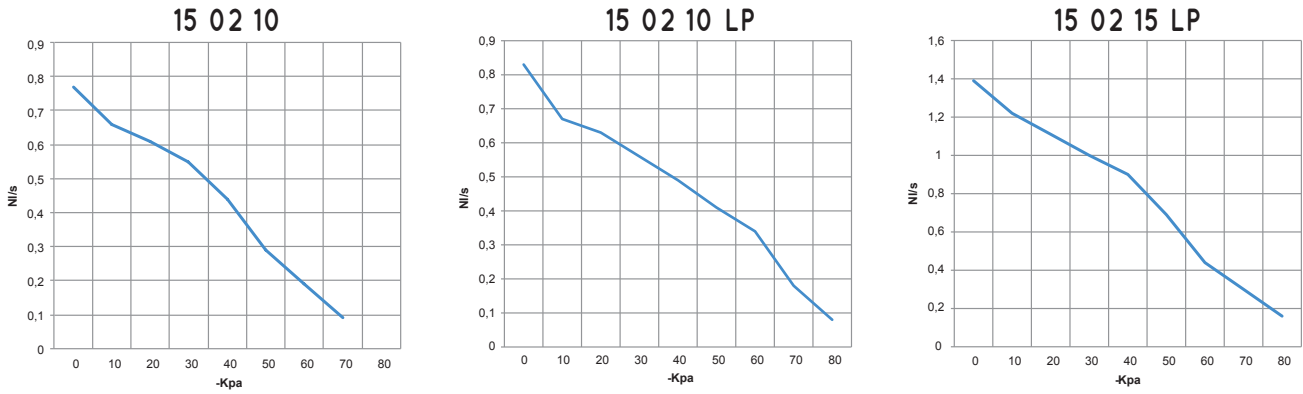

Generator item	Supp. press. bar	Air consumption NI/s	Air flow rate (NI/s) at different levels of vacuums (-KPa) at optimal supply pressure										Max vacuum -KPa
			0	10	20	30	40	50	60	70	80		
15 02 10	6.0	0.9	0.80	0.66	0.61	0.55	0.44	0.29	0.19	0.09	--	85	
15 02 10 LP	4.0	1.2	0.83	0.67	0.63	0.56	0.49	0.41	0.34	0.18	0.08	85	
15 02 15 LP	4.0	2.2	1.39	1.22	1.11	1.00	0.90	0.69	0.44	0.30	0.16	85	

Evacuation rates (ms/l = s/m³) at different levels of vacuums (-KPa) at optimal supply pressure

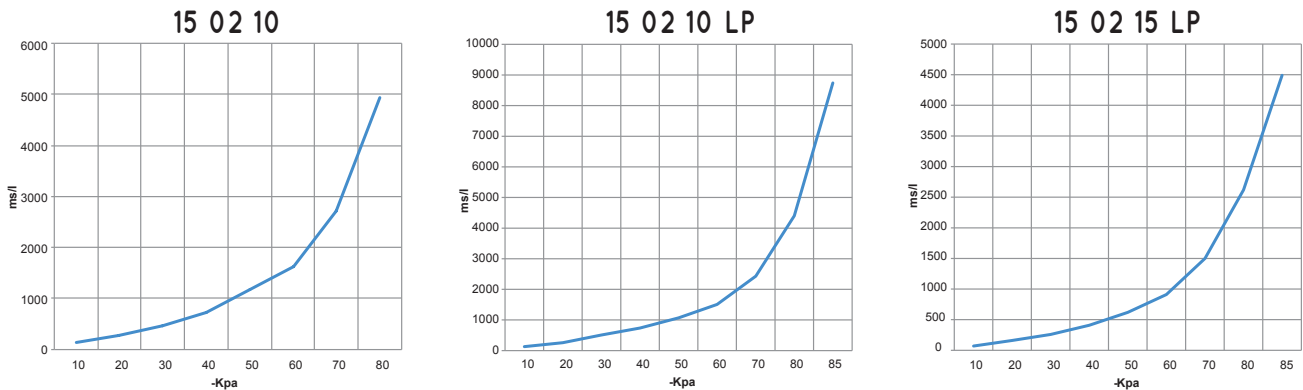

Generator item	Supp. press. bar	Air consumption NI/s	Evacuation rates (ms/l = s/m ³) at different levels of vacuums (-KPa) at optimal supply pressure									Max vacuum -KPa
			10	20	30	40	50	60	70	80	85	
15 02 10	6.0	0.9	139	278	472	727	1171	1628	2720	4928	--	85
15 02 10 LP	4.0	1.2	130	260	510	740	1070	1510	2430	4400	8740	85
15 02 15 LP	4.0	2.2	70	160	260	410	620	910	1500	2620	4490	85

ACCESSORIES UPON REQUEST

Silencer item SSX 1/4"

