

The three-way vacuum solenoid valves in this series are two-position valves with pneumatically servo-controlled conical shutters. They can be used normally either closed or open. They are composed of an anodised aluminium body, two Vulkollan® shutters assembled onto a stainless steel stem, a membrane for servo-control made with special compounds and a thrust spring for the shutter return; an actuator activated by an electric coil managed the compressed air supply. These valves allow reducing frictions and internal dynamic stresses to the minimum. The result being a high response speed and a guarantee of long lasting duration. The standard electric coil is fully plasticised with synthetic resin, tight execution, insulation class F (up to 155°C) compliant with VDE standards, with 6.3 mm three-terminal electrical connections in compliance with EN 175301-803 (ex DIN 43650). Protection degree IP 54; IP 65 with connector inserted. Tolerance permitted on the nominal voltage value: ±10%. Maximum absorption: 20 V.A. with AC and 18 W with DC. The electric coil can be rotated 360°. The connector can be rotated 180° on the coil and can be supplied, upon request, with LED lights, anti-interference circuit and/or with protection devices against overvoltage and polarity reversal. The three-way vacuum solenoid valves are used for vacuum interception on power supply units and suction palletisers, robots, feeders, bag opening units and in all those cases where rapid exchange between pump suction for vacuums and air supply into the circuit is necessary for quick restoration of atmospheric pressure.

Technical features

Operating pressure: from 0.5 to 3000 absolute mbar
 Servo-control pressure: see table
 Temperature of suctioned fluid: from -5 to +60°C

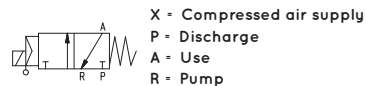
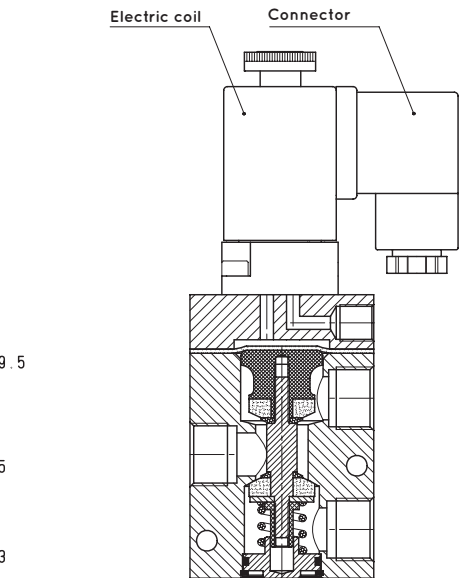
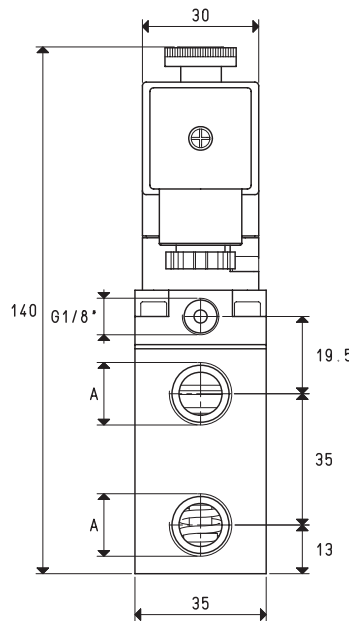
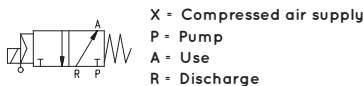
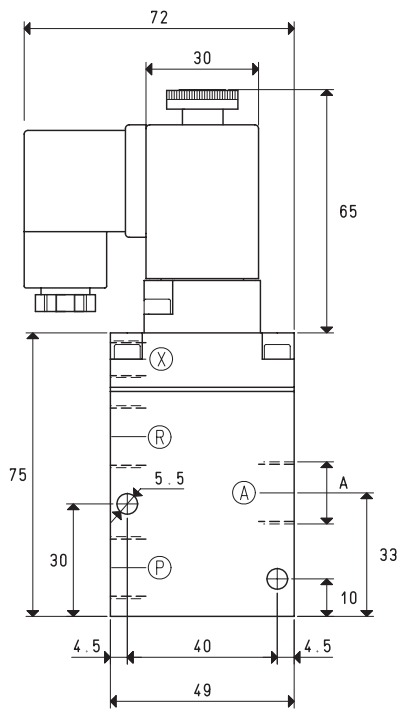

Item	A Ø	Max flow rate m³/h	Level of vacuum abs. mbar		Reaction time msec		Mouth Ø	Cross-section of passage mm²	Pressure at servo-controlled *bar	Weight Kg
			min	max	energ.	de-energ.				
07 01 11	G1/4"	6	1000	0.5	16	27	8.5	56.8	4 ÷ 7	0.56
07 02 11	G3/8"	10	1000	0.5	16	27	11.5	103.8	4 ÷ 7	0.54

Note: The coil and the connector are not integral parts of the solenoid valve and, therefore, must be ordered separately (See accessories for solenoid valves).

Solenoid valve servo-controlled power must be supplied with non-lubricated compressed air, 5 micron filtration, according to standard ISO 8573-1 class 4.

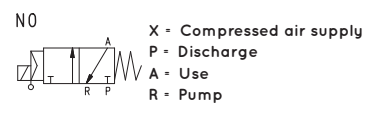
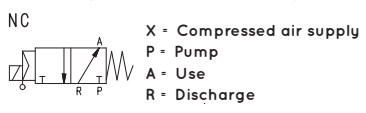
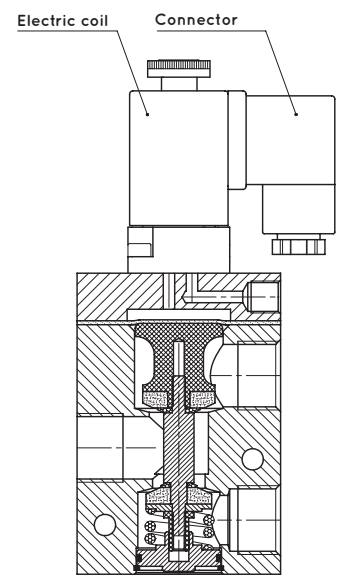
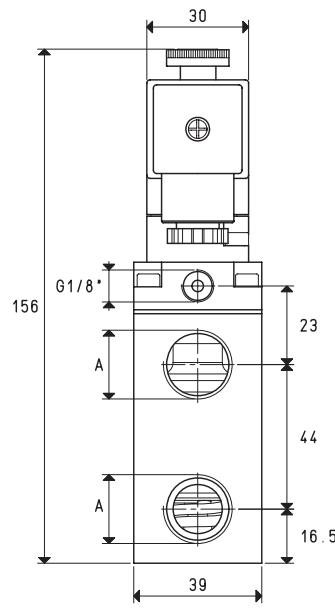
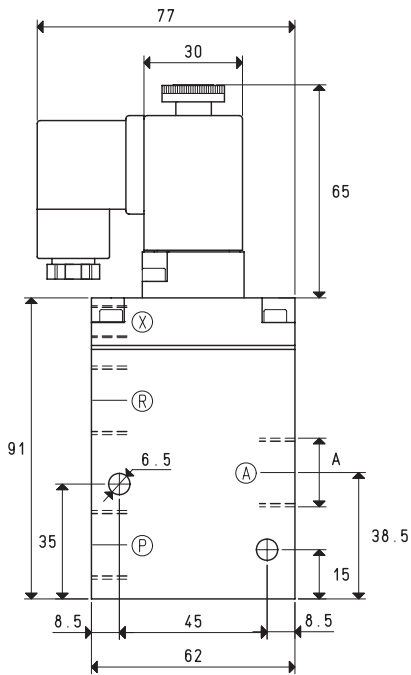

Item	A Ø	Max flow rate m³/h	Level of vacuum abs. mbar		Reaction time msec		Mouth Ø	Cross-section of passage mm²	Pressure at servo-controlled *bar	Weight Kg
			min	max	energ.	de-energ.				
07 03 11	G1/2"	20	1000	0.5	16	40	15.0	176	6 ÷ 8	0.73

* Add the letters LP to the item for servo-controlled pressures 4 - 6 bar.

Note: The coil and the connector are not integral parts of the solenoid valve and, therefore, must be ordered separately (See accessories for solenoid valves).

Solenoid valve servo-controlled power must be supplied with non-lubricated compressed air, 5 micron filtration, according to standard ISO 8573-1 class 4.

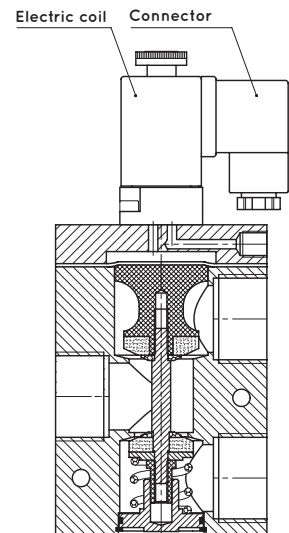
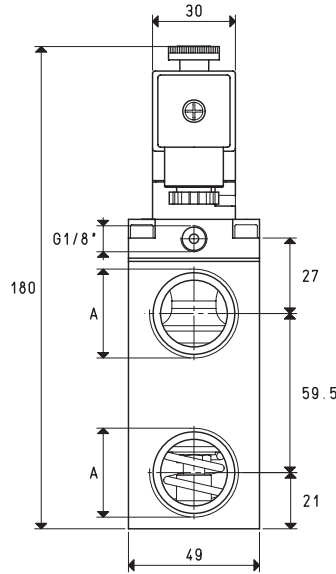
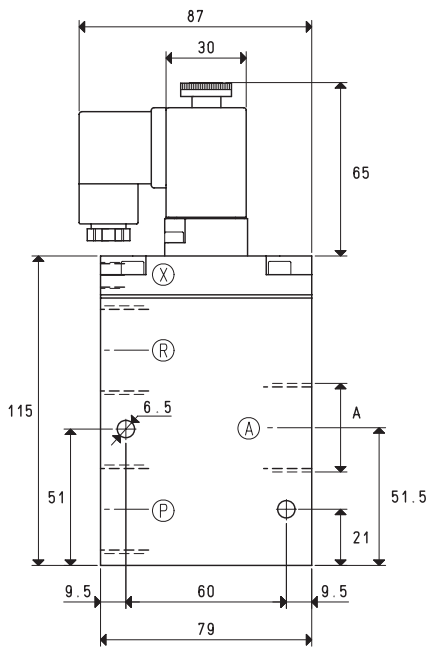

NC

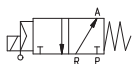

X = Compressed air supply
P = Pump
A = Use
R = Discharge

NO

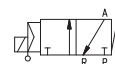

X = Compressed air supply
P = Discharge
A = Use
R = Pump

Item	A Ø	Max flow rate m ³ /h	Level of vacuum abs. mbar		Reaction time msec		Mouth Ø	Cross-section of passage mm ²	Pressure at servo-controlled *bar	Weight Kg
			min	max	energ.	de-energ.				
07 04 11	G3/4"	40	1000	0.5	16	40	20	314	6 ÷ 8	1.25
07 05 11	G1"	90	1000	0.5	18	42	25	490	6 ÷ 8	1.16

* Add the letters LP to the item for servo-controlled pressures 4 - 6 bar.

Note: The coil and the connector are not integral parts of the solenoid valve and, therefore, must be ordered separately (See accessories for solenoid valves).

Solenoid valve servo-controlled power must be supplied with non-lubricated compressed air, 5 micron filtration, according to standard ISO 8573-1 class 4.

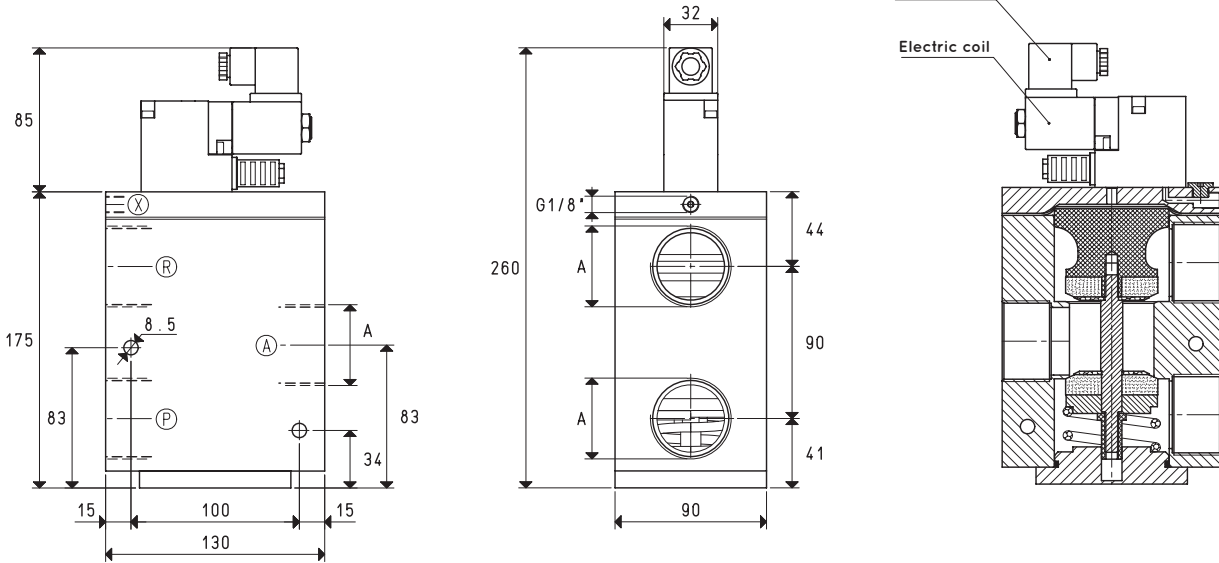

NC

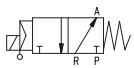

X = Compressed air supply
P = Pump
A = Use
R = Discharge

N0

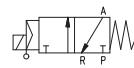

X = Compressed air supply
P = Discharge
A = Use
R = Pump

Item	A Ø	Max flow rate m³/h	Level of vacuum abs. mbar		Reaction time msec		Mouth Ø	Cross-section of passage mm²	Pressure at servo-controlled *bar	Weight Kg
			min	max	energ.	de-energ.				
07 06 11	G1" 1/2	230	1000	0.5	60	38	40	1256	6 ÷ 8	4.79

* Add the letters LP to the item for servo-controlled pressures 4 - 6 bar.

Note: The coil and the connector are not integral parts of the solenoid valve and, therefore, must be ordered separately (See accessories for solenoid valves).

Solenoid valve servo-controlled power must be supplied with non-lubricated compressed air, 5 micron filtration, according to standard ISO 8573-1 class 4.

Strengthened by our constant desire for research and innovation and our experience, acquired over more than forty years of operations in the vacuum sector, we have made these new solenoid valves using absolutely innovative technologies, to guarantee exceptionally low intervention times, almost negligible pressure drops, and minimal dimensions compared to the large connections with which they are equipped. Furthermore, we have obtained them from aluminium block to eliminate even the slightest chance of loss due to transpiration, as perhaps could occur with a fusion.

This new series of solenoid valves for vacuums are three-way, two-position and are composed of:

- An anodised aluminium body set with attachment connections
- Two conical Vulkollan® shutters fitted on the aluminium pistons, pneumatically powered with spring return

- An actuator, powered by an electrical coil to manage compressed air supply

The composition of these valves, especially the original Teflon® slide system that the pistons have been equipped with, help minimise friction and internal dynamic stress, deriving high response speed and ensuring enduring operation.

They can be used normally either closed or open.

The standard electric coil of the actuator is fully plastic-coated in synthetic resin, watertight, insulation class F (up to 155°C) as per standard VDE, with 6.3 mm three-terminal electrical connections for connectors in compliance with EN 175301-803.

Degree of protection IP 54;

IP 65 with connector inserted.

Tolerance permitted on the nominal voltage value: ± 10%.

Maximum absorption: 20 VA in AC and 18 W in DC.

The electric coil can be rotated 360°. The connector can be rotated 180° on the coil and can be supplied, upon request, with LED lights, anti-interference circuit and/or with protection devices against overvoltage and polarity reversal.

The three-way solenoid valves are used for vacuum interception on power supply units and suction palletisers, vacuum thermoformers, vacuum packaging units, robots, feeders, bag opening units and in all those cases where rapid exchange between pump suction for vacuums and air supply into the circuit is necessary for quick restoration of atmospheric pressure.

Technical features

Operating pressure: from 0.5 to 1000 absolute mbar

Servo-control pressure: from 4 to 8 bar

Temperature of suctioned fluid: from - 5 to + 60°C

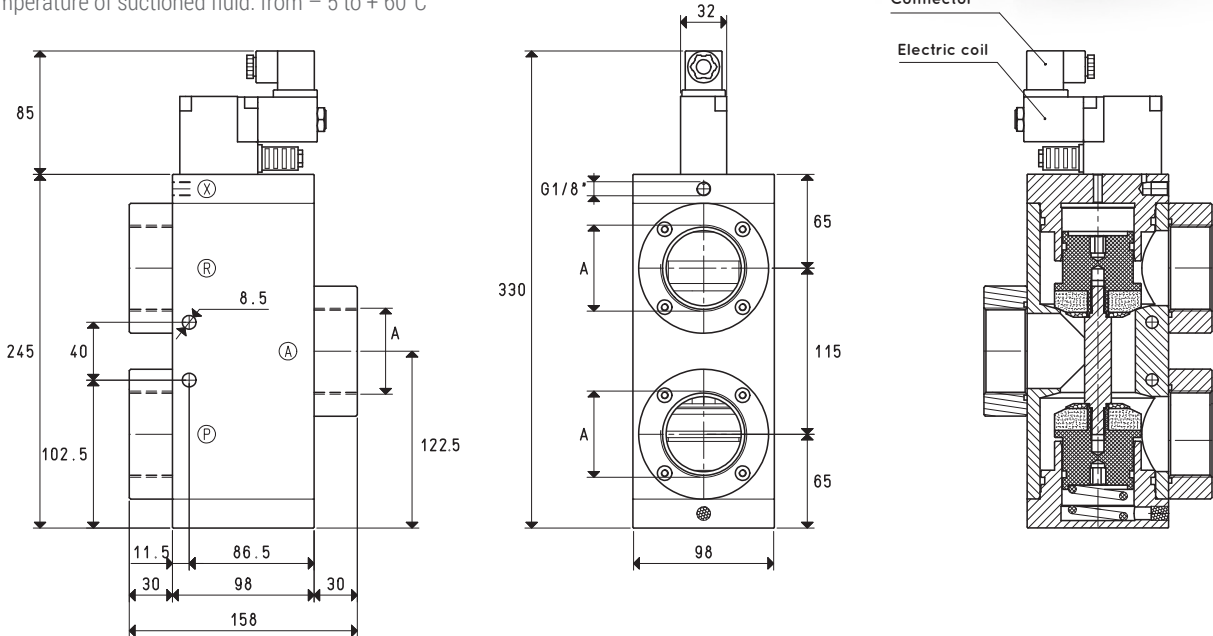

NC

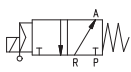

- X = Compressed air supply
- P = Pump
- A = Use
- R = Discharge

NO

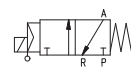

- X = Compressed air supply
- P = Discharge
- A = Use
- R = Pump

Item	A	Max flow rate	Level of vacuum		Reaction time		Mouth	Cross-section of passage	Pressure at servo-controlled	Weight
			abs. mbar	min	max	msec				
07 08 11	G2"	390	1000	0.5	78	50	52	2123	4 ÷ 8	5.87

Note: The coil and the connector are not integral parts of the solenoid valve and, therefore, must be ordered separately (See accessories for solenoid valves).

Solenoid valve servo-controlled power must be supplied with non-lubricated compressed air, 5 micron filtration, according to standard ISO 8573-1 class 4.

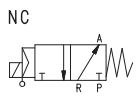
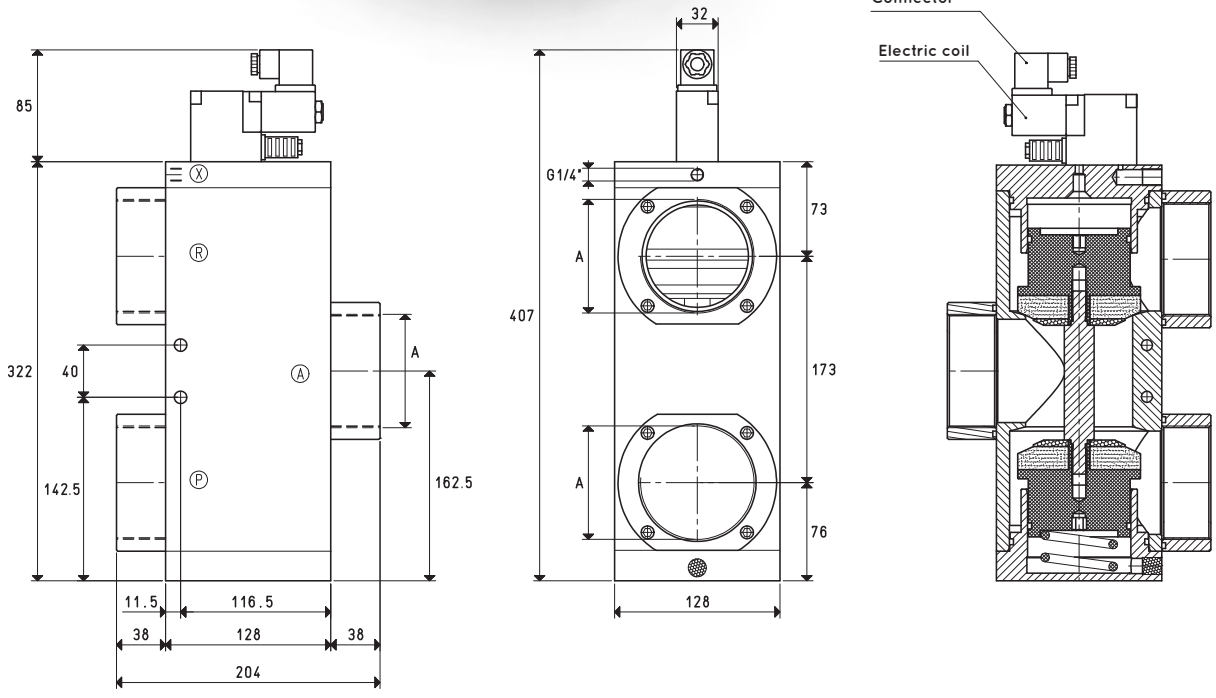

NC
 X = Compressed air supply
 P = Pump
 A = Use
 R = Discharge

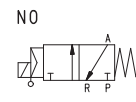

NO
 X = Compressed air supply
 P = Discharge
 A = Use
 R = Pump

Item	A Ø	Max flow rate m³/h	Level of vacuum abs. mbar		Reaction time msec		Mouth Ø	Cross-section of passage mm²	Pressure at servo-controlled *bar	Weight Kg
			min	max	energ.	de-energ.				
07 09 11	G3"	750	1000	0.5	132	84	80	5024	4 ÷ 8	11.8

Note: The coil and the connector are not integral parts of the solenoid valve and, therefore, must be ordered separately (See accessories for solenoid valves).
 Solenoid valve servo-controlled power must be supplied with non-lubricated compressed air, 5 micron filtration, according to standard ISO 8573-1 class 4.