

These direct drive three-way, two-position vacuum solenoid valves feature conical shutters servo-controlled by the vacuum. They are normally closed as standard, but they can be supplied normally open upon request. They are composed of an anodised aluminium body where the connections are located, two silicone shutters assembled onto a stainless steel stem and a membrane in special reinforced compound. An actuator activated by an electric coil manages the vacuum at the servo-control. The operating principle of these solenoid valves is based on the pressure differential between the vacuum pump or generator and the pressure of the suctioned air. By addressing this "differential pressure" to the servo-control via the actuator, the shutters can be controlled without compressed air or springs. Due to their operating principle, they are not recommended on plants with rough vacuum levels (below 850 absolute mbar, equal to 15 % vacuum). The lack of springs, frictions and internal dynamic stresses favours a high response speed and guarantees long lasting operation. The standard electric coil is fully plasticised with synthetic resin, tight execution, insulation class F (up to 155°C) compliant with VDE standards, with 6.3 mm three-terminal electrical connections in compliance with EN 175301-803 (ex DIN 43650). Protection degree IP 54; IP 65 with connector inserted. Tolerance permitted on the nominal voltage value: ±10%. Maximum absorption: 20 V.A. with AC and 18 W with DC. The electric coil can be rotated 360°. The connector can be rotated 180° on the coil and can be supplied, upon request, with LED lights, anti-interference circuit and/or with protection devices against overvoltage and polarity reversal. The solenoid valves in this series, along with the uses described for the 07 .. 11 series, can be used on plants with no compressed air. The solenoid valve must be always chosen according to the flow rate and, therefore, to the vacuum pump or generator suction connection.

Technical features

Operating pressure: from 0.5 to 850 absolute mbar
 Temperature of suctioned fluid: from -5 to +60°C

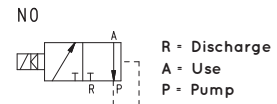
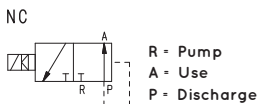
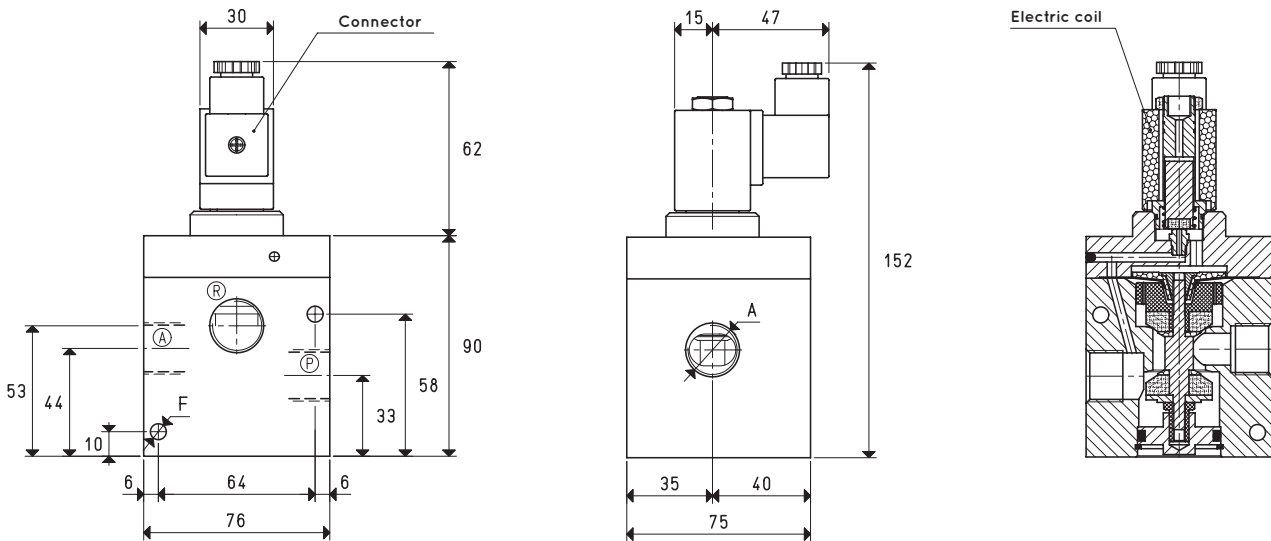

Item	A Ø	Max flow rate m³/h	Level of vacuum abs. mbar		Reaction time msec		Mouth Ø	Cross-section of passage mm²	F Ø	Weight Kg
			min	max	energ.	de-energ.				
07 03 40 NC	G1/2"	20	850	0.5	30	15	15	176	6.5	1.53
07 03 40 NO					20	18				
07 04 40 NC	G3/4"	40	850	0.5	30	15	20	314	6.5	1.50
07 04 40 NO					20	18				

Note: The coil and the connector are not integral parts of the solenoid valve and, therefore, must be ordered separately (See accessories for solenoid valves).

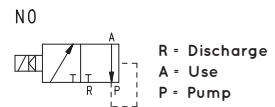
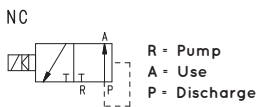
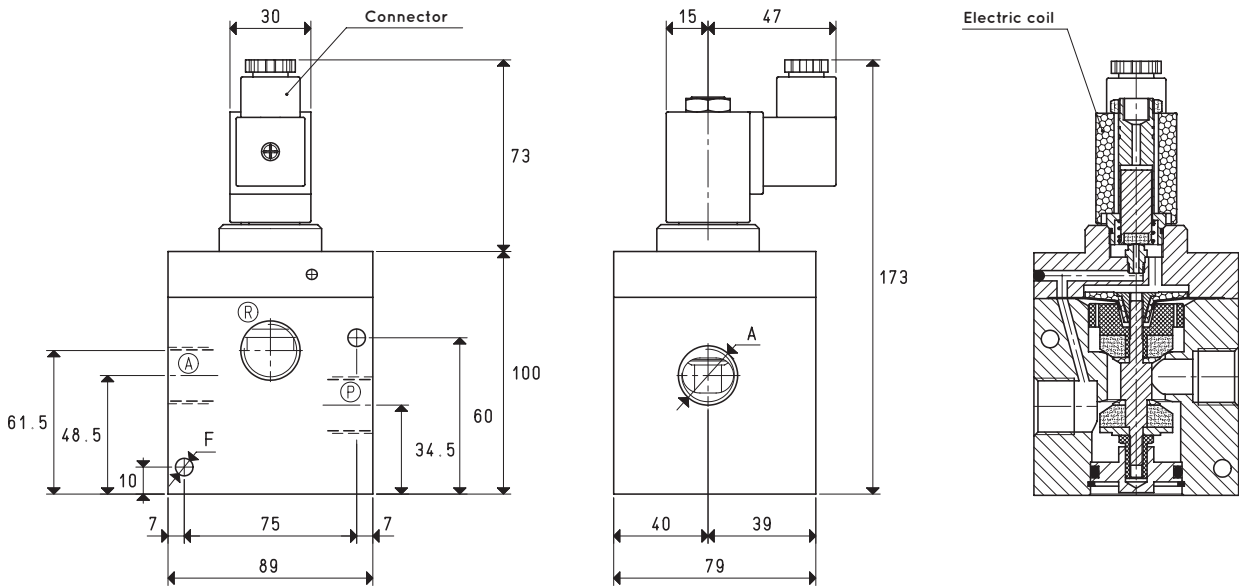

Item	A	Max flow rate	Level of vacuum		Reaction time		Mouth	Cross-section of passage	F	Weight
			abs. mbar	min	max	msec				
	Ø	m ³ /h					Ø	mm ²	Ø	Kg
07 05 40 NC	G1"	90	850	0.5	38	18	25	490	6.5	1.91
07 05 40 NO					25	20				

Note: The coil and the connector are not integral parts of the solenoid valve and, therefore, must be ordered separately (See accessories for solenoid valves).

Transformation ratio: N (newton) = Kg x 9.81 (force of gravity)

inch = $\frac{\text{mm}}{25.4}$; pounds = $\frac{\text{g}}{453.6} = \frac{\text{Kg}}{0.4536}$

Adapters for GAS - NPT threading available on page 1.130

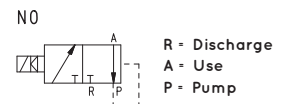
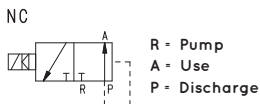
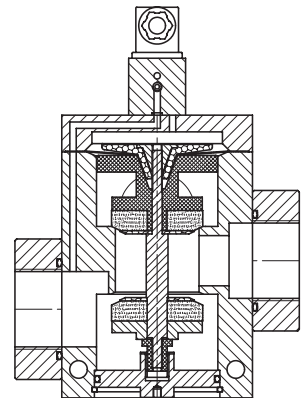
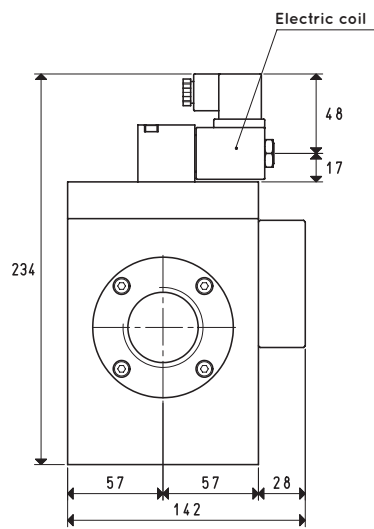
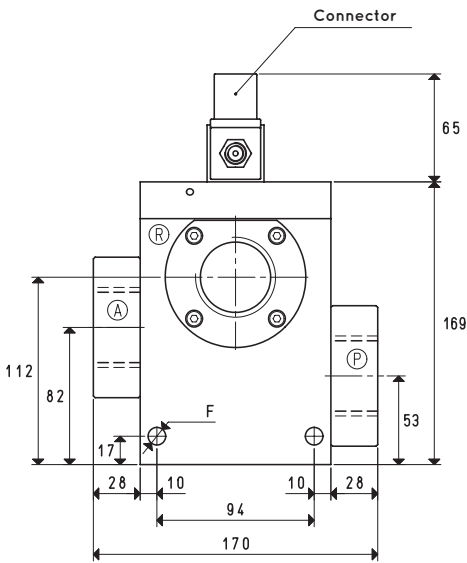

Item	A	Max flow rate	Level of vacuum		Reaction time		Mouth	Cross-section of passage	F	Weight
			abs. mbar	min	max	msec				
07 06 40 NC	G1" 1/2	230	850	0.5	75	50	40	1256	10.5	5.90
07 06 40 NO					70	60				

Note: The coil and the connector are not integral parts of the solenoid valve and, therefore, must be ordered separately (See accessories for solenoid valves).