

The manufacturers of glass and marble machining centres require increasingly accurate and safe clamping systems. This has led us to creating this new series of cups.

They are vulcanised onto a steel support and are provided with a hole in the centre for vacuum connection or for a BALL VALVE, as well as with 2 holes on the internal circumference for housing allen screws.

Their extremely flexible lip allows them to easily adapt themselves to the sheets to be held, with no risk of deformation or rupture, even for the thinnest ones. The particular internal support plane of these cups ensure a high friction coefficient with the gripping surface and a considerable grip on wet glass and marble sheets, thanks to the water drainage. All this guarantees a firm and safe grip.

Furthermore, these cups feature the highest accuracy of their thickness, whose nominal height has a tolerance of only five hundredths of millimetre.

They are normally produced with oil-resistant rubber A, but they can be ordered in other compounds, listed at page 21, upon request and in minimum quantities to be defined in the order.

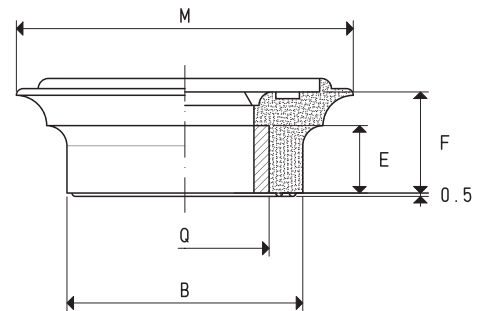
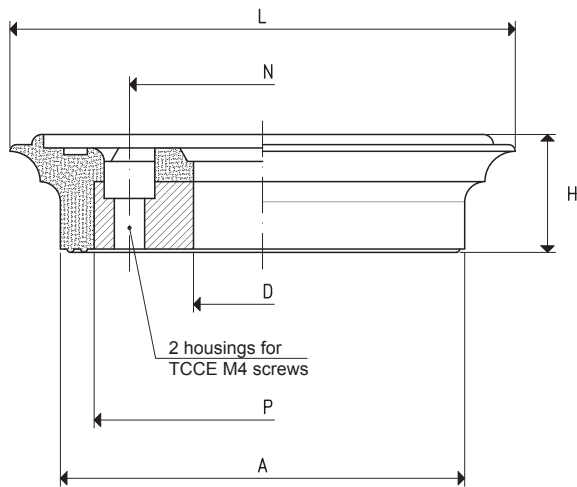

CUP WITH VULCANISED SUPPORT

Art.	Force Kg	A	B	D ∅	E	F	H	L	M	N	P	Q	Support material	Weight g
08 50 75 A	7.5	60	35	20.5	10	15	17.5	75	50	39.5	50	25	steel	92

Conversion ratio: inch = $\frac{\text{mm.}}{25.4}$; pounds = $\frac{\text{g}}{453.6} = \frac{\text{Kg}}{0.4536}$