

These cups have been designed to solve many of the gripping and handling problems we have encountered in over thirty years of activity. They differ from all the other cups for the variety of their shapes.

They are suited for gripping CDs, labels, bags, paper or plastic sheets, stickers, cardboard, metal and plastic objects, biscuits, chocolates, etc.

Their nickel-plated brass or anodised aluminium supports are provided with a threaded male or female pin to enable suction and to fasten them to the machine.

These cups can be manually assembled onto their supports with no adhesives. They are available in the standard compounds, but they can also be provided in the special compounds listed at page 21 in minimum amounts to be defined in the order.

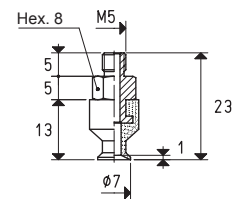
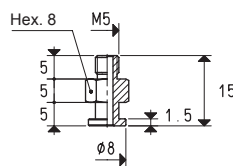
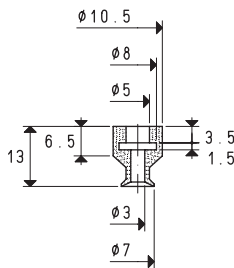

Cup Art.	Force Kg	Support Art.	Support material	Weight g	Cup with support Art.	Weight g
01 07 13 *	0.10	00 08 236	brass	3	08 07 13 *	3.6

\* Complete the code indicating the compound: A= oil-resistant rubber; N= natural para rubber; S= silicon

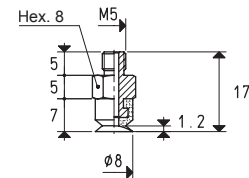
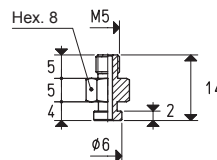
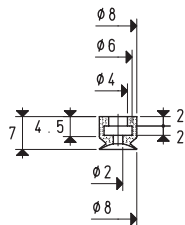

Cup Art.	Force Kg	Support Art.	Support material	Weight g	Cup with support Art.	Weight g
01 08 07 *	0.13	00 08 237	brass	3	08 08 07 *	3.1

\* Complete the code indicating the compound: A= oil-resistant rubber; N= natural para rubber; S= silicon

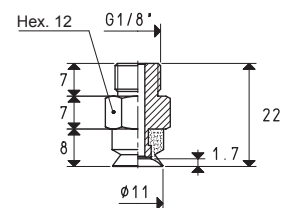
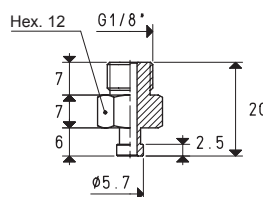
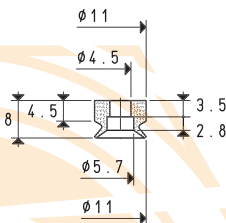

Cup Art.	Force Kg	Support Art.	Support material	Weight g	Cup with support Art.	Weight g
01 11 08 *	0.24	00 08 238	brass	7	08 11 08 *	7.6

\* Complete the code indicating the compound: A= oil-resistant rubber; N= natural para rubber; S= silicon

Conversion ratio:  $\text{inch} = \frac{\text{mm}}{25.4}$ ;  $\text{pounds} = \frac{\text{Kg}}{453.6} = \frac{\text{Kg}}{0.4536}$

GAS - NPT thread adapters available at page 1.117

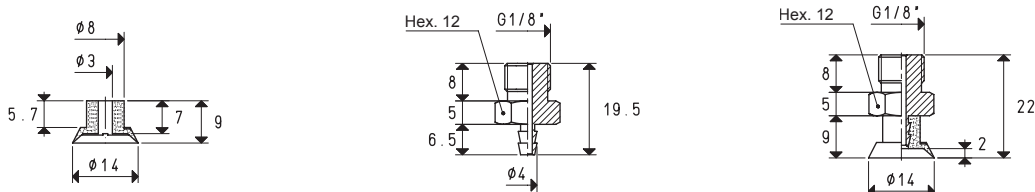

Cup Art.	Force Kg	Support Art.	Support Material	Weight g	Cups with support Art.	Weight g
01 14 09 *	0.38	00 08 239	brass	8.0	08 14 09 *	8.3

\* Complete the code indicating the compound: A= oil-resistant rubber; N= natural para rubber; S= silicon

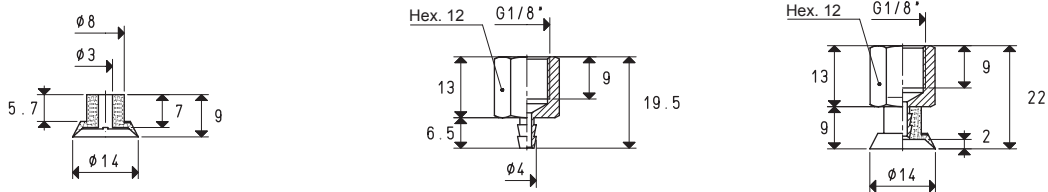

Cup Art.	Force Kg	Support Art.	Support material	Weight g	Cup with support Art.	Weight g
01 14 09 *	0.38	00 08 240	brass	7.0	08 14 09 F *	7.3

\* Complete the code indicating the compound: A= oil-resistant rubber; N= natural para rubber; S= silicon

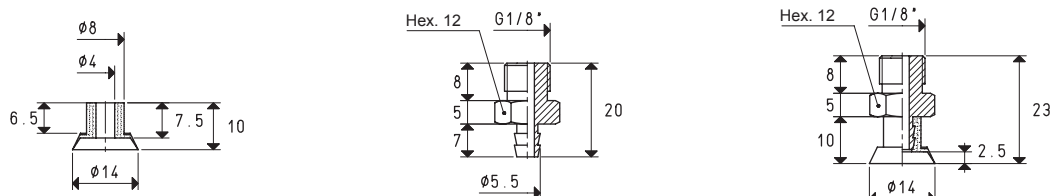

Cup Art.	Force Kg	Support Art.	Support material	Weight g	Cup with support Art.	Weight g
01 14 10 *	0.38	00 08 03	brass	9.0	08 14 10 *	9.4

\* Complete the code indicating the compound: A= oil-resistant rubber; N= natural para rubber; S= silicon

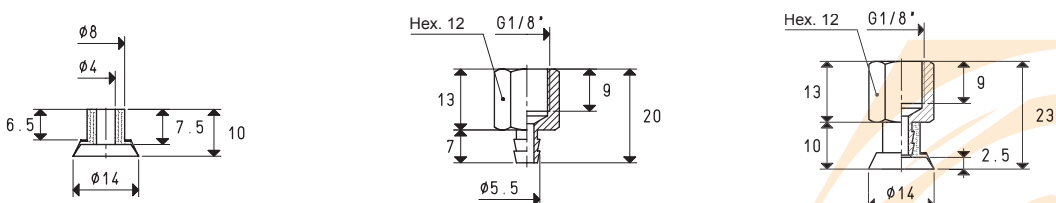

Cup Art.	Force Kg	Support Art.	Support material	Weight g	Cup with support Art.	Weight g
01 14 10 *	0.38	00 08 04	brass	8.1	08 14 10 F *	8.5

\* Complete the code indicating the compound: A= oil-resistant rubber; N= natural para rubber; S= silicon

Conversion ratio: inch =  $\frac{\text{mm}}{25.4}$  ; pounds =  $\frac{\text{g}}{453.6} = \frac{\text{Kg}}{0.4536}$

GAS - NPT thread adapters available at page 1.117

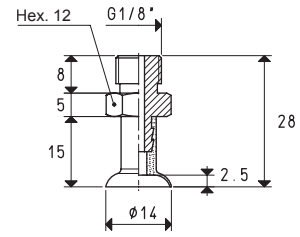
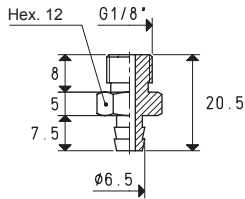
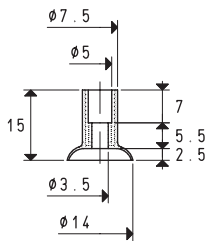

Cup Art.	Force Kg	Support Art.	Support material	Weight g	Cup with support Art.	Weight g
01 14 15 *	0.38	00 08 67	brass	11.4	08 14 15 *	11.9

\* Complete the code indicating the compound: A= oil-resistant rubber; N= natural para rubber; S= silicon

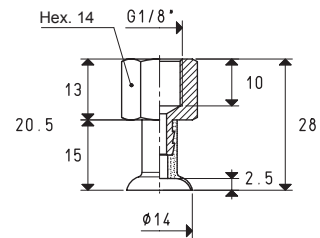
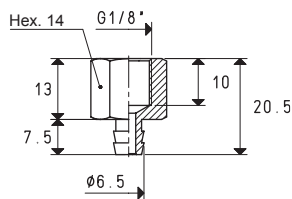
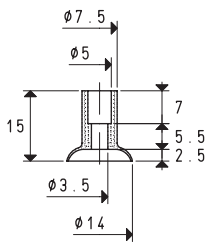

Cup Art.	Force Kg	Support Art.	Support material	Weight g	Cup with support Art.	Weight g
01 14 15 *	0.38	00 08 64	brass	13.9	08 14 15 F *	14.4

\* Complete the code indicating the compound: A= oil-resistant rubber; N= natural para rubber; S= silicon

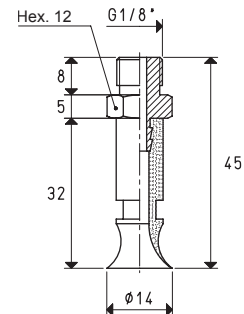
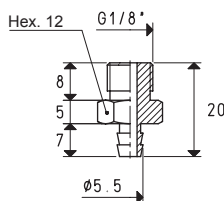
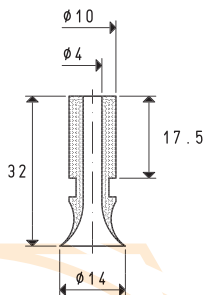

Cup Art.	Force Kg	Support Art.	Support material	Weight g	Cup with support Art.	Weight g
01 14 32 *	0.38	00 08 03	brass	9.0	08 14 32 *	10.9

\* Complete the code indicating the compound: A= oil-resistant rubber; N= natural para rubber; S= silicon

Conversion ratio: inch =  $\frac{\text{mm}}{25.4}$ ; pounds =  $\frac{\text{g}}{453.6} = \frac{\text{Kg}}{0.4536}$

GAS - NPT thread adapters available at page 1.117

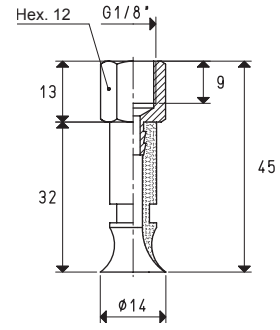
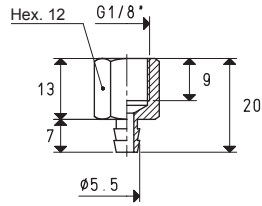
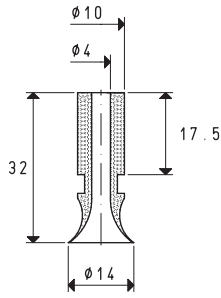

Cup Art.	Force Kg	Support Art.	Support material	Weight g	Cup with support Art.	Weight g
01 14 32 *	0.38	00 08 04	brass	8.1	08 14 32 F *	10.0

\* Complete the code indicating the compound: A= oil-resistant rubber; N= natural para rubber; S= silicon

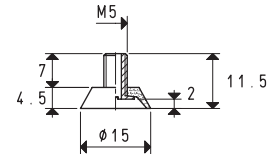
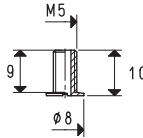
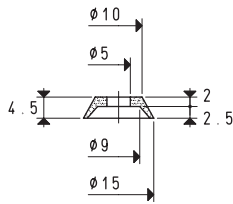

Cup Art.	Force Kg	Support Art.	Support material	Weight g	Cup with support Art.	Weight g
01 15 04 *	0.44	00 08 241	brass	1.5	08 15 04 *	1.7

\* Complete the code indicating the compound: A= oil-resistant rubber; N= natural para rubber; S= silicon

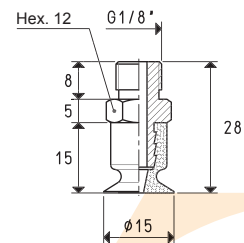
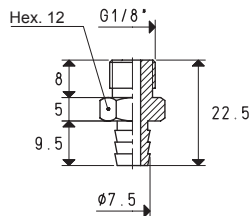
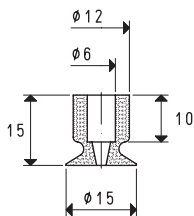

Cup Art.	Force Kg	Support Art.	Support material	Weight g	Cups with support Art.	Weight g
01 15 15 *	0.03	00 08 05	brass	10.4	08 15 15 *	11.7

\* Complete the code indicating the compound: A= oil-resistant rubber; N= natural para rubber; S= silicon

Conversion ratio: inch =  $\frac{mm}{25.4}$  ; pounds =  $\frac{g}{453.6}$  =  $\frac{Kg}{0.4536}$

GAS - NPT thread adapters available at page 1.117

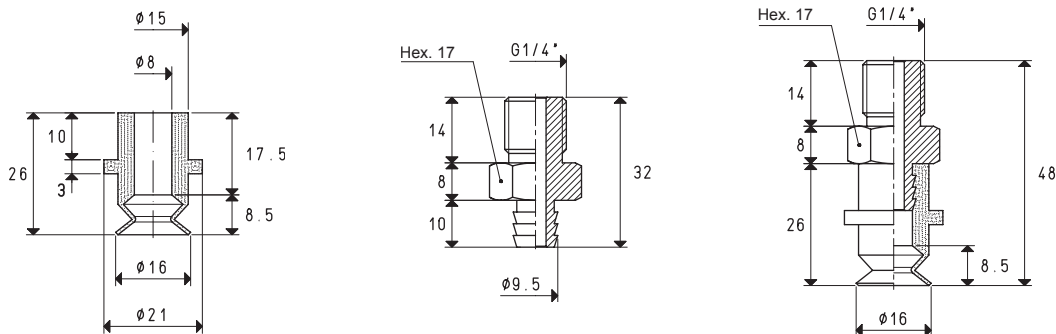

Cup Art.	Force Kg	Support Art.	Support material	Weight g	Cup with support Art.	Weight g
01 16 26 *	0.50	00 08 18	aluminium	10.3	08 16 26 *	13.7

\* Complete the code indicating the compound: A= oil-resistant rubber; N= natural para rubber; S= silicon

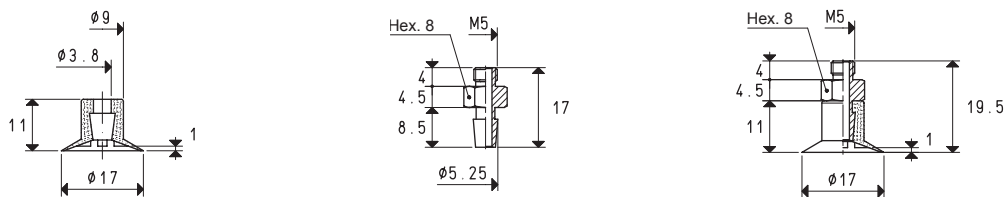

Cup Art.	Force Kg	Support Art.	Support material	Weight g	Cup with support Art.	Weight g
01 17 12 *	0.60	00 08 06	brass	2.6	08 17 12 *	3.3

\* Complete the code indicating the compound: A= oil-resistant rubber; N= natural para rubber; S= silicon

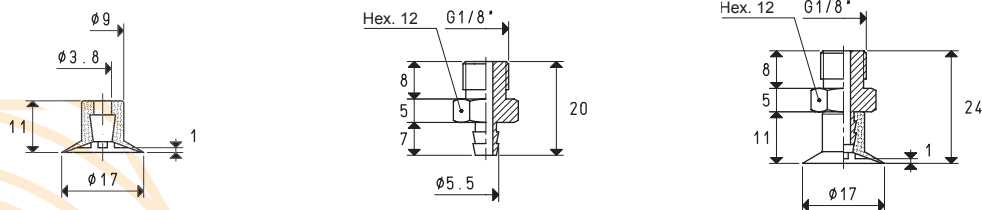

Cup Art.	Force Kg	Support Art.	Support material	Weight g	Cup with support Art.	Weight g
01 17 12 *	0.60	00 08 03	brass	9.0	08 17 13 *	9.7

\* Complete the code indicating the compound: A= oil-resistant rubber; N= natural para rubber; S= silicon

Conversion ratio: inch =  $\frac{mm}{25.4}$ ; pounds =  $\frac{g}{453.6}$  =  $\frac{Kg}{0.4536}$

GAS - NPT thread adapters available at page 1.117

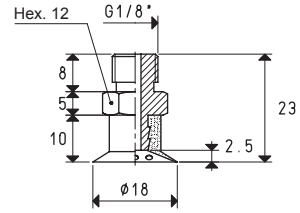
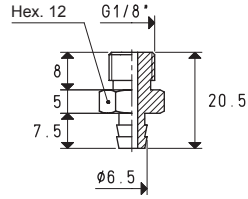
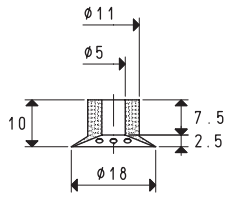

Cup Art.	Force Kg	Support Art.	Support material	Weight g	Cup with support Art.	Weight g
01 18 12 *	0.63	00 08 67	brass	11.4	08 18 12 *	12.2

\* Complete the code indicating the compound: A= oil-resistant rubber; N= natural para rubber; S= silicon

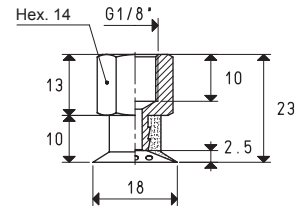
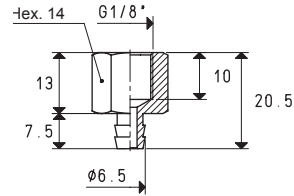
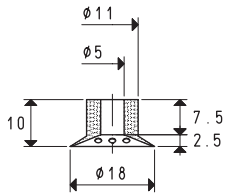

Cup Art.	Force Kg	Support Art.	Support material	Weight g	Cup with support Art.	Weight g
01 18 12 *	0.63	00 08 64	brass	13.9	08 18 12 F *	14.7

\* Complete the code indicating the compound: A= oil-resistant rubber; N= natural para rubber; S= silicon

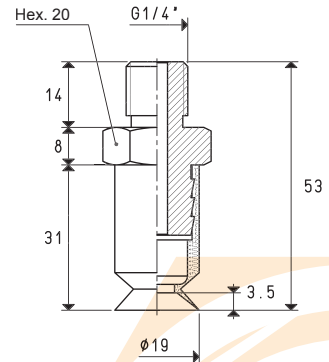
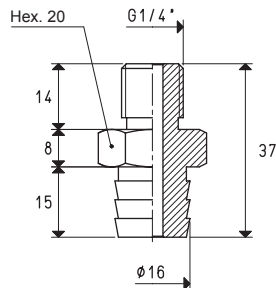
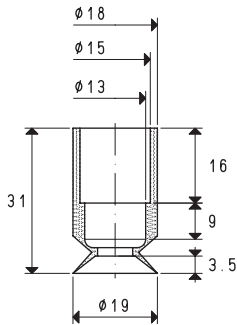

Cup Art.	Force Kg	Support Art.	Support material	Weight g	Cup with support Art.	Weight g
01 19 31 *	0.70	00 08 09	aluminium	18.1	08 19 31 *	20.9

\* Complete the code indicating the compound: A= oil-resistant rubber; N= natural para rubber; S= silicon

Conversion ratio: inch =  $\frac{mm}{25.4}$ ; pounds =  $\frac{g}{453.6} = \frac{Kg}{0.4536}$

GAS - NPT thread adapters available at page 1.117

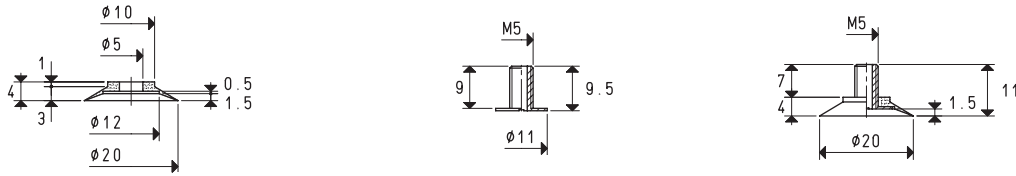

Cup Art.	Force Kg	Support Art.	Support material	Weight g	Cup with support Art.	Weight g
01 20 04 *	0.78	00 08 242	brass	1.8	08 20 04 *	2.0

\* Complete the code indicating the compound: A= oil-resistant rubber; N= natural para rubber; S= silicon

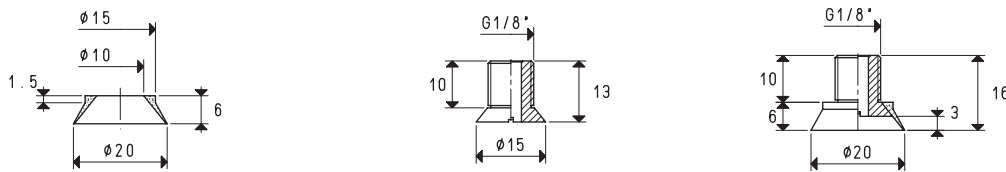

Cup Art.	Force Kg	Support Art.	Support material	Weight g	Cup with support Art.	Weight g
01 20 06 *	0.78	00 08 243	brass	6.0	08 20 06 *	6.3

\* Complete the code indicating the compound: A= oil-resistant rubber; N= natural para rubber; S= silicon

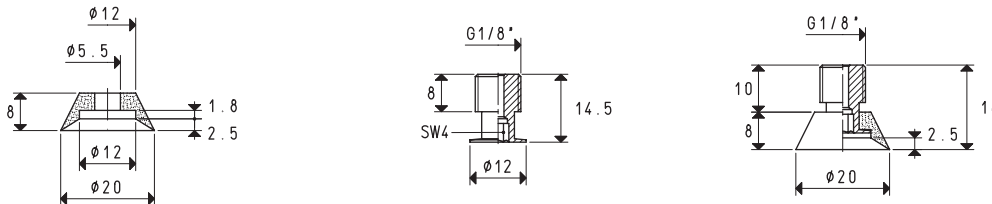

Cup Art.	Force Kg	Support Art.	Support material	Weight g	Cup with support Art.	Weight g
01 20 08 *	0.78	00 08 60	brass	5.6	08 20 08 *	6.4

\* Complete the code indicating the compound: A= oil-resistant rubber; N= natural para rubber; S= silicon

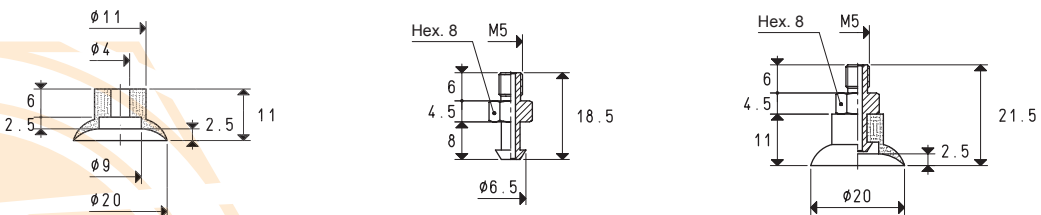

Cup Art.	Force Kg	Support Art.	Support material	Weight g	Cup with support Art.	Weight g
01 20 11 *	0.78	00 08 245	brass	2.7	08 20 11 *	3.7

\* Complete the code indicating the compound: A= oil-resistant rubber; N= natural para rubber; S= silicon

$$\text{Conversion ratio: inch} = \frac{\text{mm}}{25.4}, \text{ pounds} = \frac{\text{g}}{453.6} = 0.4536$$

GAS - NPT thread adapters available at page 1.117

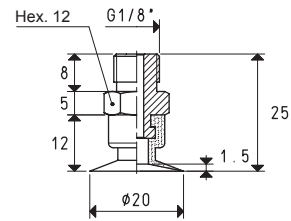
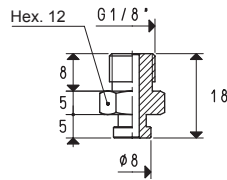
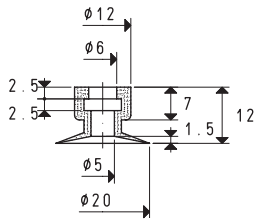

Cup Art.	Force Kg	Support Art.	Support material	Weight g	Cup with support Art.	Weight g
01 20 12 *	0.78	00 08 146	brass	9.8	08 20 12 *	10.7

\* Complete the code indicating the compound: A= oil-resistant rubber; N= natural para rubber; S= silicon

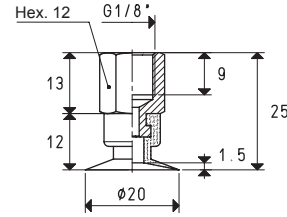
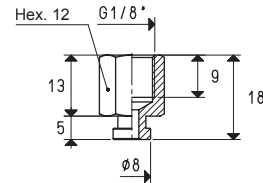
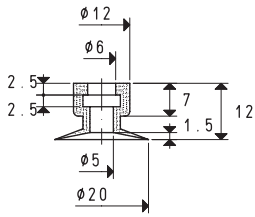

Cup Art.	Force Kg	Support Art.	Support material	Weight g	Cup with support Art.	Weight g
01 20 12 *	0.78	00 08 155	brass	9.1	08 20 12 F *	10.0

\* Complete the code indicating the compound: A= oil-resistant rubber; N= natural para rubber; S= silicon

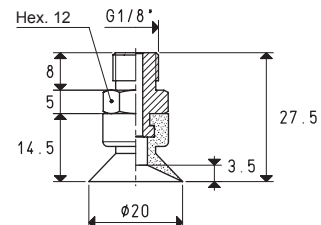
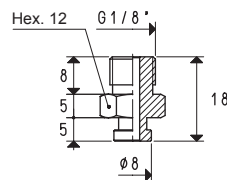
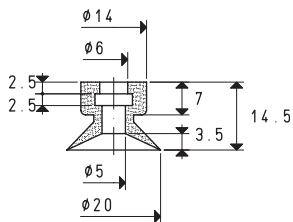

Cup Art.	Force Kg	Support Art.	Support material	Weight g	Cup with support Art.	Weight g
01 20 14 *	0.78	00 08 146	brass	9.8	08 20 14 *	11.3

\* Complete the code indicating the compound: A= oil-resistant rubber; N= natural para rubber; S= silicon

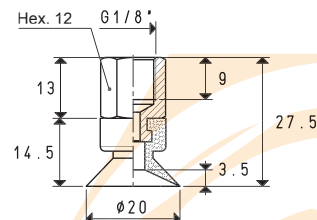
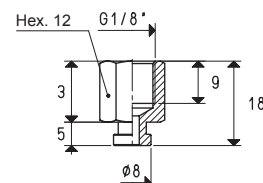
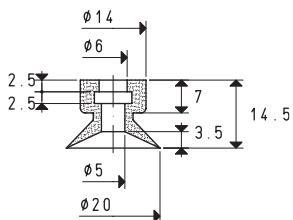

Cup Art.	Force Kg	Support Art.	Support material	Weight g	Cup with support Art.	Weight g
01 20 14 *	0.78	00 08 155	brass	9.1	08 20 14 F *	10.6

\* Complete the code indicating the compound: A= oil-resistant rubber; N= natural para rubber; S= silicon

Conversion ratio: inch =  $\frac{mm}{25.4}$  ; pounds =  $\frac{g}{453.6} = \frac{Kg}{0.4536}$

GAS - NPT thread adapters available at page 1.117



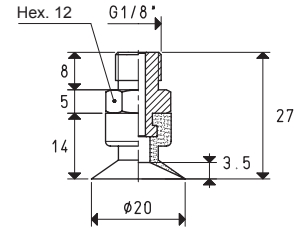
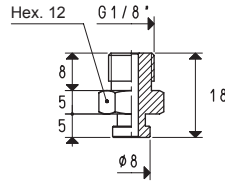
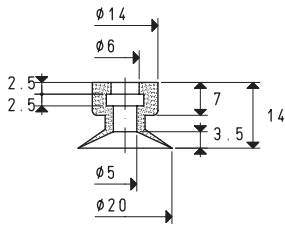

Cup Art.	Force Kg	Support Art.	Support material	Weight g	Cup with support Art.	Weight g
01 20 15 *	0.78	00 08 146	brass	9.8	08 20 15 *	11.0

\* Complete the code indicating the compound: A= oil-resistant rubber; N= natural para rubber; S= silicon

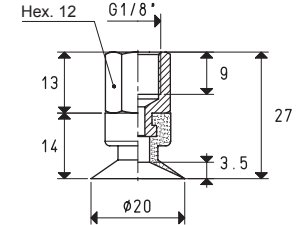
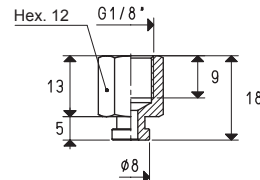
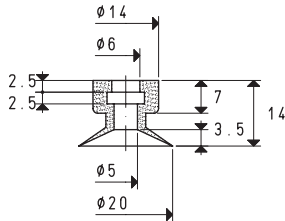

Cup Art.	Force Kg	Support Art.	Support material	Weight g	Cup with support Art.	Weight g
01 20 15 *	0.78	00 08 155	brass	9.1	08 20 15 F *	10.3

\* Complete the code indicating the compound: A= oil-resistant rubber; N= natural para rubber; S= silicon

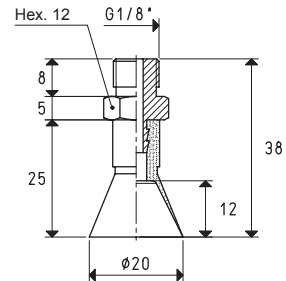
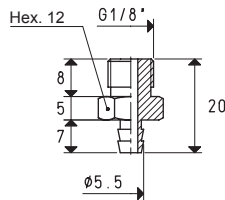
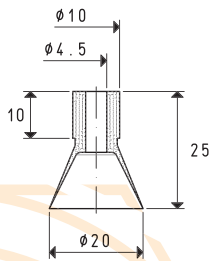

Cup Art.	Force Kg	Support Art.	Support material	Weight g	Cup with support Art.	Weight g
01 20 24 *	0.78	00 08 03	brass	9.0	08 20 24 *	10.2

\* Complete the code indicating the compound: A= oil-resistant rubber; N= natural para rubber; S= silicon

Conversion ratio:  $\text{inch} = \frac{\text{mm}}{25.4}$ ;  $\text{pounds} = \frac{\text{g}}{453.6} = 0.4536$

GAS - NPT thread adapters available at page 1.117

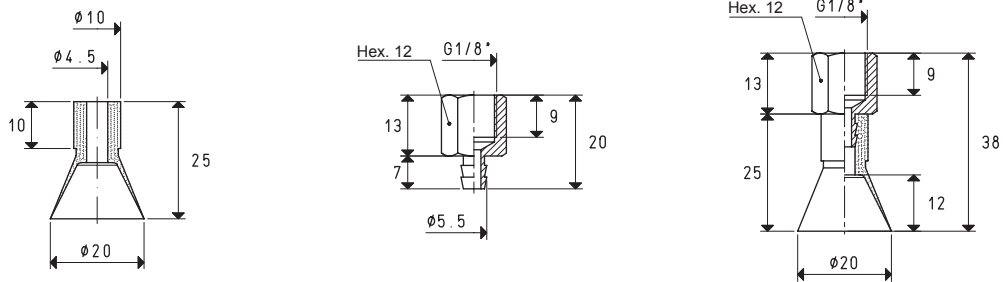

Cup Art.	Force Kg	Support Art.	Support material	Weight g	Cup with support Art.	Weight g
01 20 24 *	0.78	00 08 04	brass	8.1	08 20 24 F *	9.3

\* Complete the code indicating the compound: A= oil-resistant rubber; N= natural para rubber; S= silicon

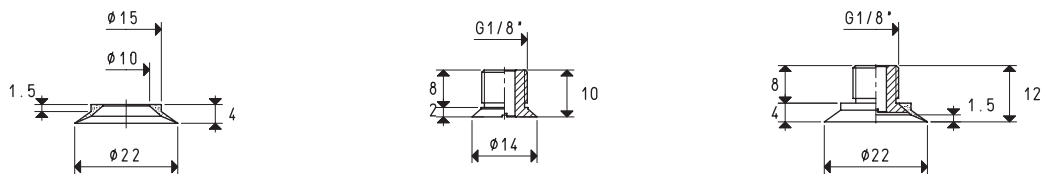

Cup Art.	Force Kg	Support Art.	Support material	Weight g	Cup with support Art.	Weight g
01 22 06 *	0.95	00 08 246	brass	5.0	08 22 06 *	5.3

\* Complete the code indicating the compound: A= oil-resistant rubber; N= natural para rubber; S= silicon

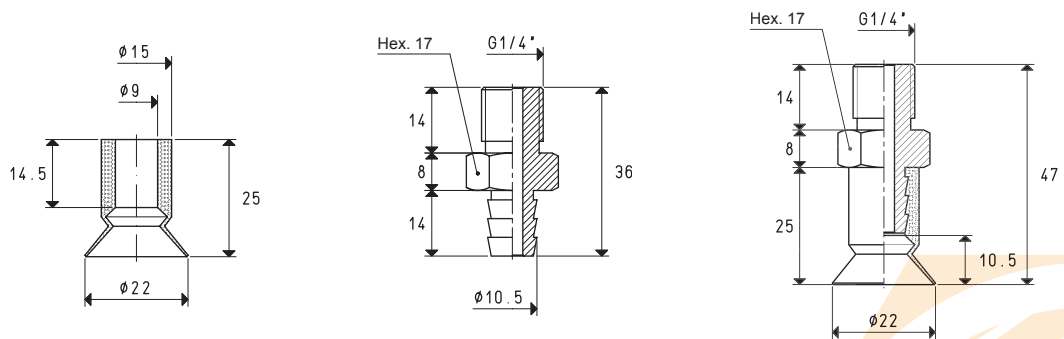

Cup Art.	Force Kg	Support Art.	Support material	Weight g	Cup with support Art.	Weight g
01 22 24 *	0.95	00 08 10	brass	30.3	08 22 24 *	32.9

\* Complete the code indicating the compound: A= oil-resistant rubber; N= natural para rubber; S= silicon

Conversion ratio: inch =  $\frac{mm}{25.4}$  ; pounds =  $\frac{g}{453.6}$  =  $\frac{Kg}{0.4536}$

GAS - NPT thread adapters available at page 1.117

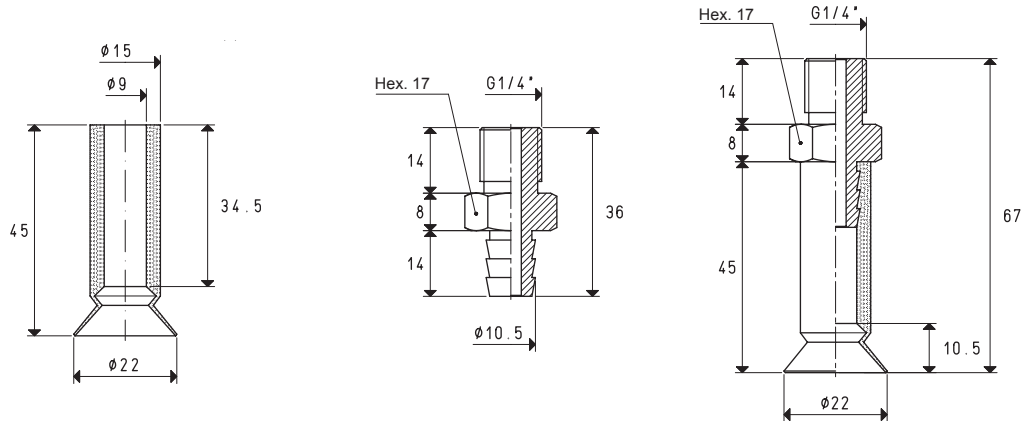

Cup Art.	Force Kg	Support Art.	Support material	Weight g	Cup with support Art.	Weight g
01 22 45 *	0.95	00 08 10	brass	30.3	08 22 45 *	35.4

\* Complete the code indicating the compound: A= oil-resistant rubber; N= natural para rubber; S= silicon

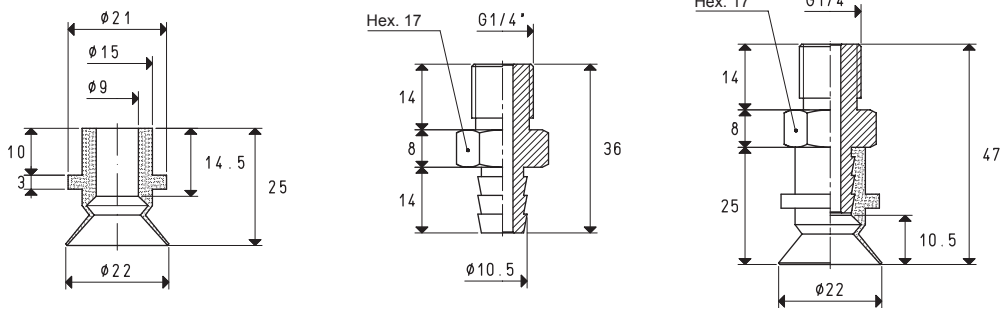

Cup Art.	Force Kg	Support Art.	Support material	Weight g	Cup with support Art.	Weight g
01 22 99 *	0.95	00 08 10	brass	30.3	08 22 99 *	33.1

\* Complete the code indicating the compound: A= oil-resistant rubber; N= natural para rubber; S= silicon

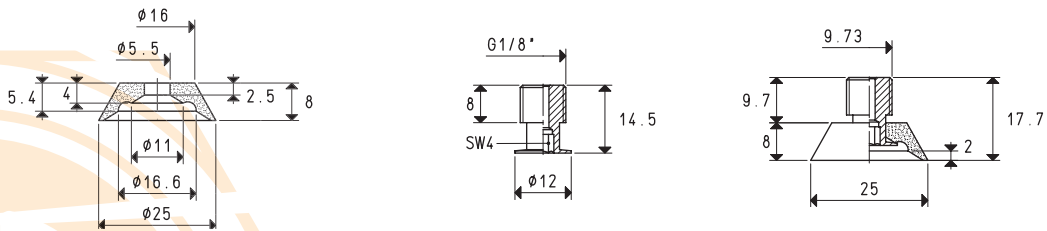

Cup Art.	Force Kg	Support Art.	Support material	Weight g	Cup with support Art.	Weight g
01 25 08 *	1.23	00 08 60	brass	5.6	08 25 08 *	7.4

\* Complete the code indicating the compound: A= oil-resistant rubber; N= natural para rubber; S= silicon

Conversion ratio:  $\text{inch} = \frac{\text{mm}}{25.4}$ ,  $\text{pounds} = \frac{\text{g}}{453.6} = 0.4536$

GAS - NPT thread adapters available at page 1.117



# SPECIAL CUPS WITH SUPPORT

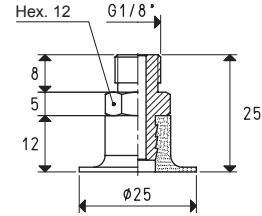
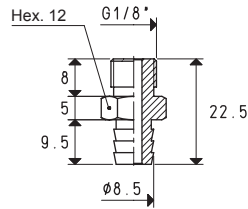
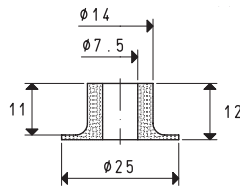

Cup Art.	Force Kg	Support Art.	Support material	Weight g	Cup with support Art.	Weight g
01 25 12 *	0.11	00 08 82	brass	11.2	08 25 12 *	12.7

\* Complete the code indicating the compound: A= oil-resistant rubber; N= natural para rubber; S= silicon

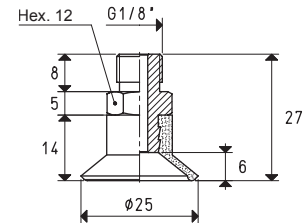
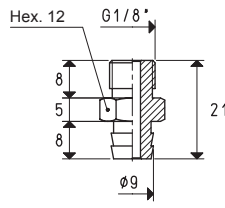
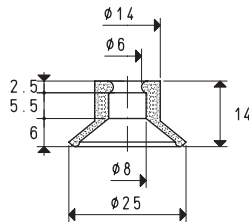

cup Art.	Force Kg	Support Art.	Support material	Weight g	Cup with support Art.	Weight g
01 25 14 *	1.23	00 08 101	brass	10.8	08 25 14 *	12.6

\* Complete the code indicating the compound: A= oil-resistant rubber; N= natural para rubber; S= silicon

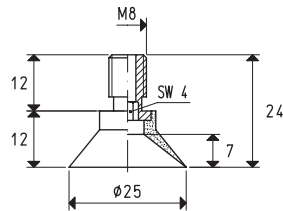

Cup with vulcanised support art.	Force Kg	Support material	Weight g
08 25 22 *	1.23	steel	5.0

\* Complete the code indicating the compound: A= oil-resistant rubber; N= natural para rubber; S= silicon

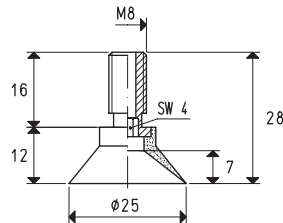

Cup with vulcanised support art.	Force Kg	Support material	Weight g
08 25 27 *	1.23	steel	5.2

\* Complete the code indicating the compound: A= oil-resistant rubber; N= natural para rubber; S= silicon

Conversion ratio: inch =  $\frac{mm}{25.4}$ ; pounds =  $\frac{g}{453.6}$  =  $\frac{Kg}{0.4536}$  GAS - NPT thread adapters available at page 1.117

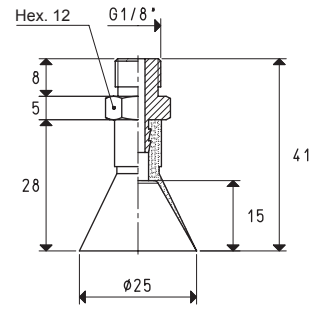
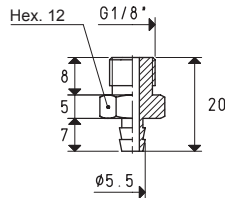
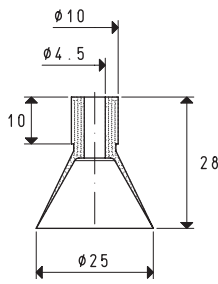

Cup Art.	Force Kg	Support Art.	Support material	Weight g	Cup with support Art.	Weight g
01 25 28 *	1.23	00 08 03	brass	9.0	08 25 28 *	10.7

\* Complete the code indicating the compound: A= oil-resistant rubber; N= natural para rubber; S= silicon

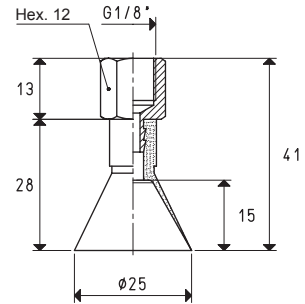
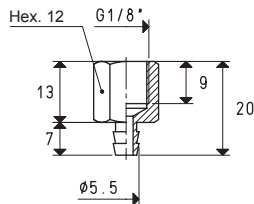
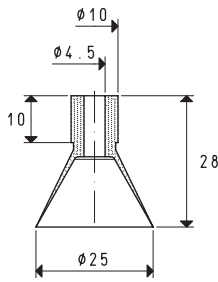

Cup Art.	Force Kg	Support Art.	Support material	Weight g	Cup with support Art.	Weight g
01 25 28 *	1.23	00 08 04	brass	8.1	08 25 28 F *	9.8

\* Complete the code indicating the compound: A= oil-resistant rubber; N= natural para rubber; S= silicon

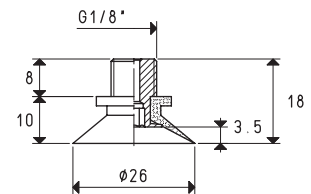
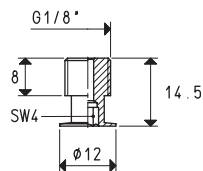
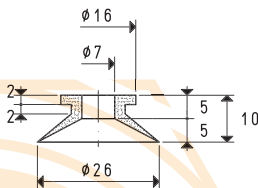

Cup Art.	Force Kg	Support Art.	Support material	Weight g	Cup with support Art.	Weight g
01 26 10 *	1.33	00 08 60	brass	5.6	08 26 10 *	6.5

\* Complete the code indicating the compound: A= oil-resistant rubber; N= natural para rubber; S= silicon

Conversion ratio: inch =  $\frac{\text{mm}}{25.4}$ ; pounds =  $\frac{\text{g}}{453.6} = \frac{\text{Kg}}{0.4536}$

GAS - NPT thread adapters available at page 1.117

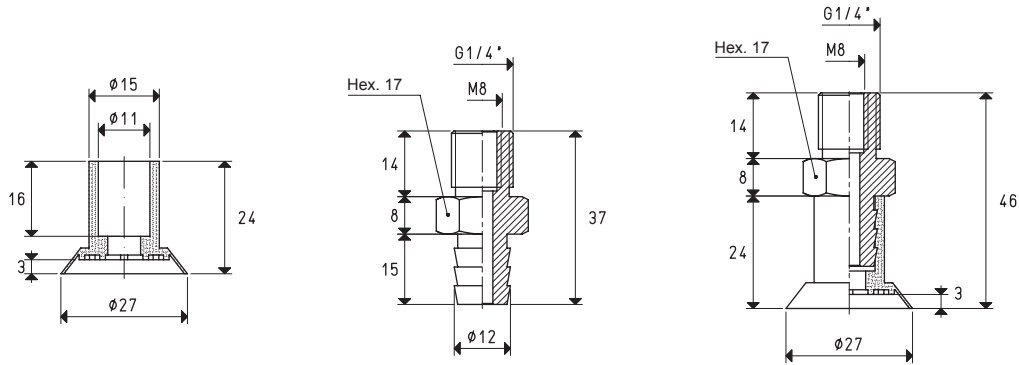

Cup Art.	Force Kg	Support Art.	Support material	Weight g	Cup with support Art.	Weight g
01 27 24 *	1.43	00 08 15	aluminium	12.3	08 27 24 *	15.1

\* Complete the code indicating the compound: A= oil-resistant rubber; N= natural para rubber; S= silicon

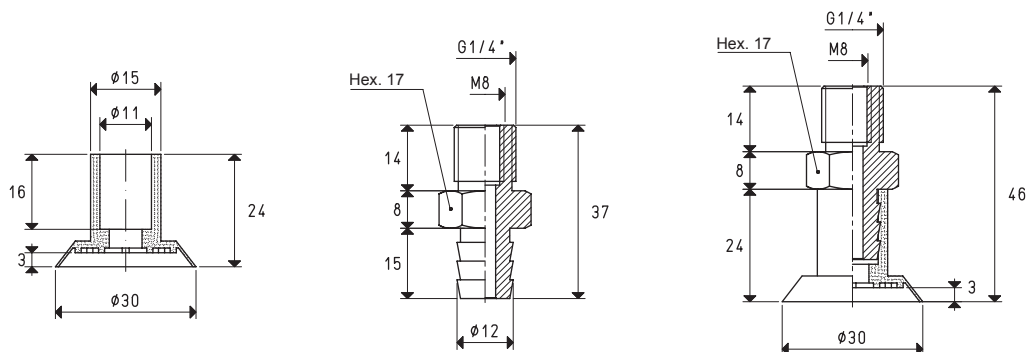

Cup Art.	Force Kg	Support Art.	Support material	Weight g	Cup with support Art.	Weight g
01 30 24 *	1.76	00 08 15	aluminium	12.3	08 30 24 *	15.2

\* Complete the code indicating the compound: A= oil-resistant rubber; N= natural para rubber; S= silicon

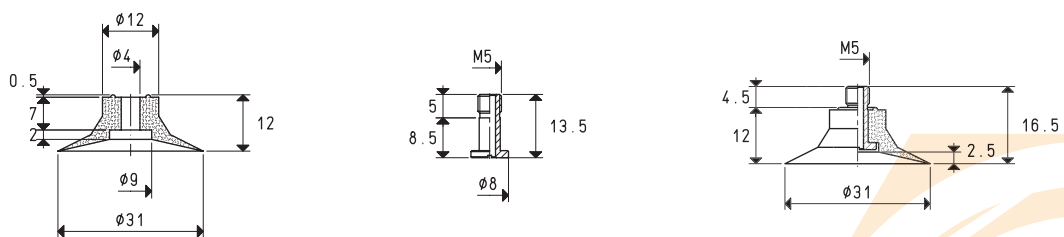

Cup Art.	Force Kg	Support Art.	Support material	Weight g	Cup with support Art.	Weight g
01 31 12 *	1.89	00 08 249	brass	1.8	08 31 12 *	3.4

\* Complete the code indicating the compound: A= oil-resistant rubber; N= natural para rubber; S= silicon

Conversion ratio:  $\text{inch} = \frac{\text{mm}}{25.4}$ ;  $\text{pounds} = \frac{\text{g}}{453.6} = \frac{\text{Kg}}{0.4536}$

GAS - NPT thread adapters available at page 1.117

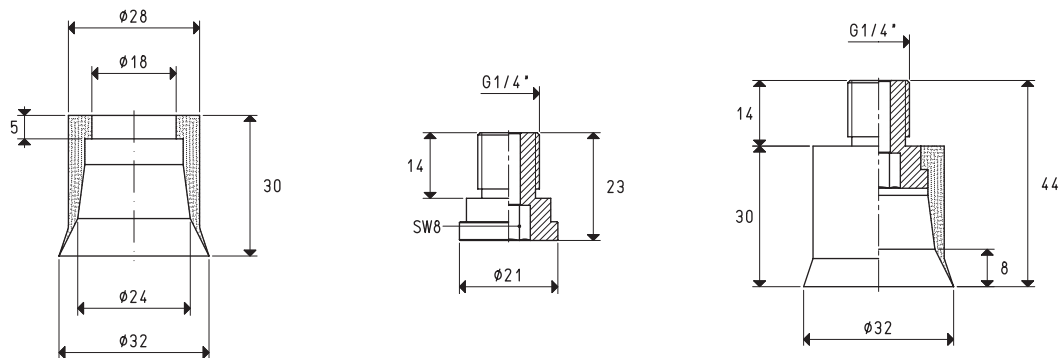

Cup Art.	Force Kg	Support Art.	Support material	Weight g	Cup with support Art.	Weight g
01 32 30 *	2.00	00 08 250	aluminium	8.6	08 32 30 *	14.5

\* Complete the code indicating the compound: A= oil-resistant rubber; N= natural para rubber; S= silicon

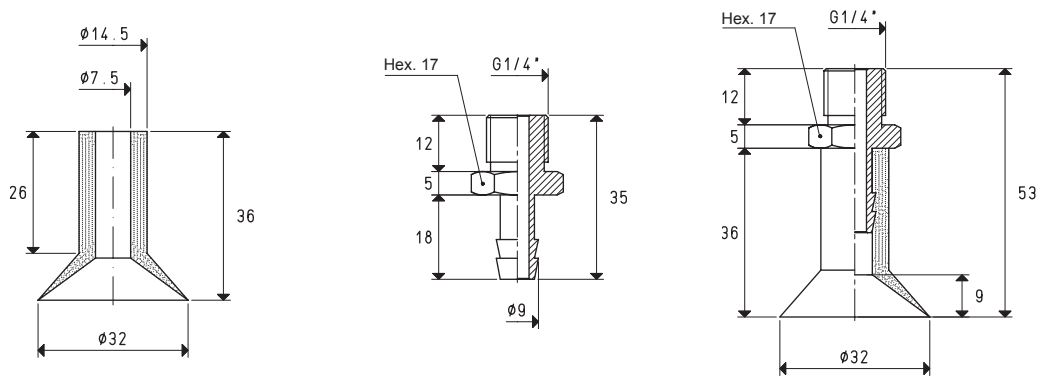

Cup Art.	Force Kg	Support Art.	Support material	Weight g	Cup with support Art.	Weight g
01 32 36 *	2.00	00 08 19	brass	22.7	08 32 36 *	27.8

\* Complete the code indicating the compound: A= oil-resistant rubber; N= natural para rubber; S= silicon

Conversion ratio:  $\text{inch} = \frac{\text{mm}}{25.4}$ ;  $\text{pounds} = \frac{\text{g}}{453.6} = \frac{\text{Kg}}{0.4536}$

GAS - NPT thread adapters available at page 1.117

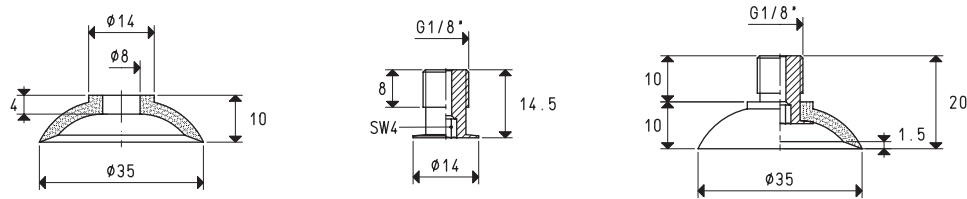

Cup Art.	Force Kg	Support Art.	Support material	Weight g	Cup with support Art.	Weight g
01 35 12 *	2.40	00 08 244	brass	5.9	08 35 12 *	8.8

\* Complete the code indicating the compound: A= oil-resistant rubber; N= natural para rubber; S= silicon

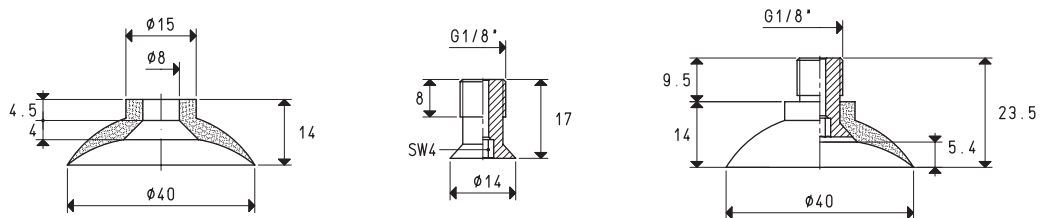

Cup Art.	Force Kg	Support Art.	Support material	Weight g	Cup with support Art.	Weight g
01 40 14 *	3.14	00 08 247	brass	8.4	08 40 14 *	12.7

\* Complete the code indicating the compound: A= oil-resistant rubber; N= natural para rubber; S= silicon

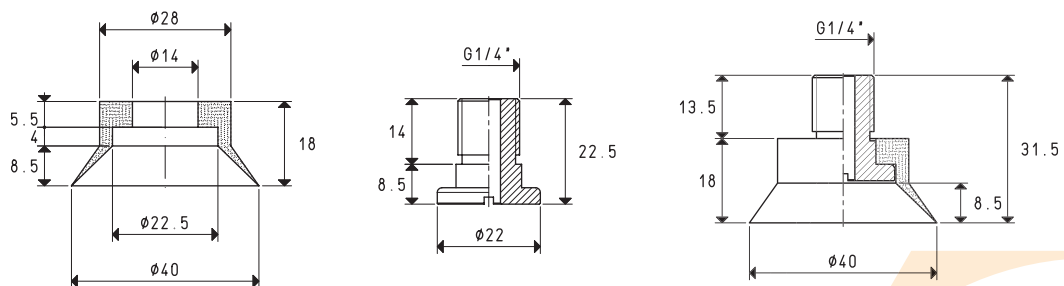

Cup Art.	Force Kg	Support Art.	Support material	Weight g	Cup with support. Art.	Weight g
01 40 18 *	3.14	00 08 81	aluminium	8.8	08 40 18 *	15.0

\* Complete the code indicating the compound: A= oil-resistant rubber; N= natural para rubber; S= silicon

Conversion ratio: inch =  $\frac{mm}{25.4}$ ; pounds =  $\frac{g}{453.6}$  =  $\frac{Kg}{0.4536}$

GAS - NPT thread adapters available at page 1.117



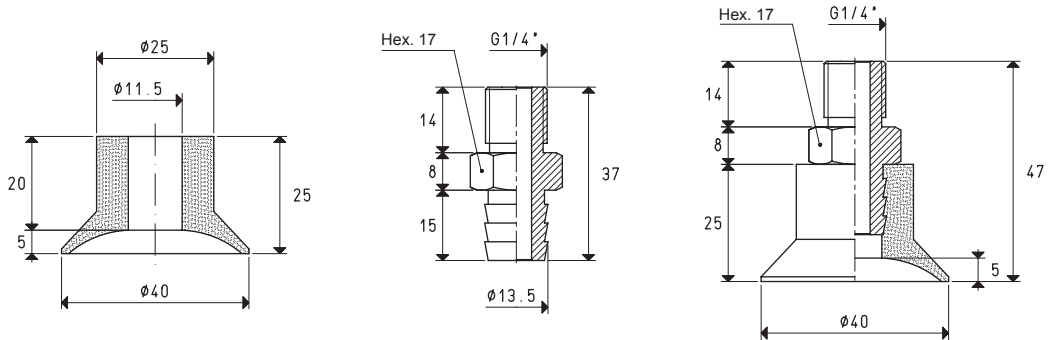

Cup Art.	Force Kg	Support Art.	Support material	Weight g	Cup with support Art.	Weight g
01 40 25 *	3.14	00 08 127	aluminium	15.2	08 40 24 *	24.7

\* Complete the code indicating the compound: A= oil-resistant rubber; N= natural para rubber; S= silicon

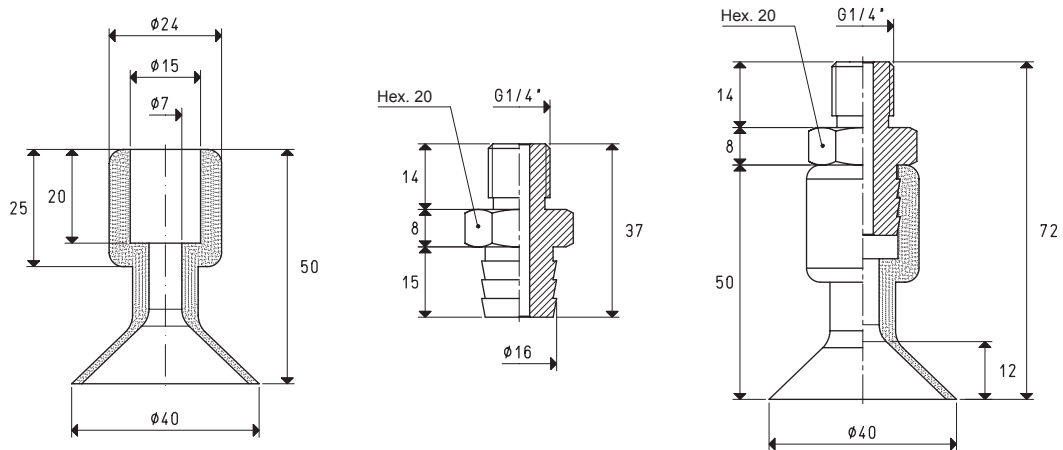

Cup Art.	Force Kg	Support Art.	Support material	Weight g	Cup with support Art.	Weight g
01 40 70 *	3.14	00 08 09	aluminium	18.1	08 40 70 *	32.0

\* Complete the code indicating the compound: A= oil-resistant rubber; N= natural para rubber; S= silicon

Conversion ratio: inch =  $\frac{\text{mm}}{25.4}$ ; pounds =  $\frac{\text{g}}{453.6} = \frac{\text{Kg}}{0.4536}$

GAS - NPT thread adapters available at page 1.117

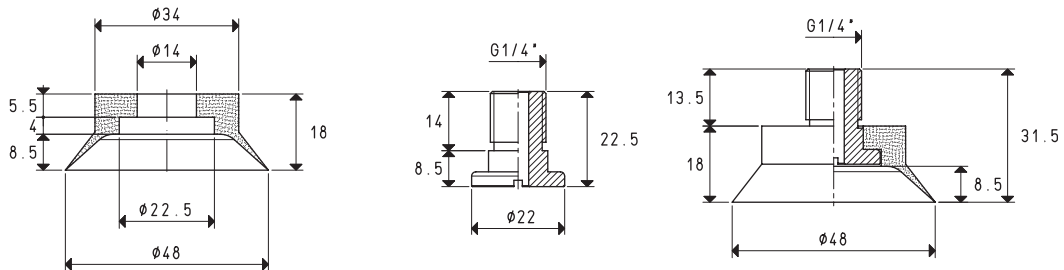

Cup Art.	Force Kg	Support Art.	Support material	Weight g	Cup with support Art.	Weight g
01 48 18 *	4.52	00 08 81	aluminium	8.8	08 48 18 *	17.5

\* Complete the code indicating the compound: A= oil-resistant rubber; N= natural para rubber; S= silicon

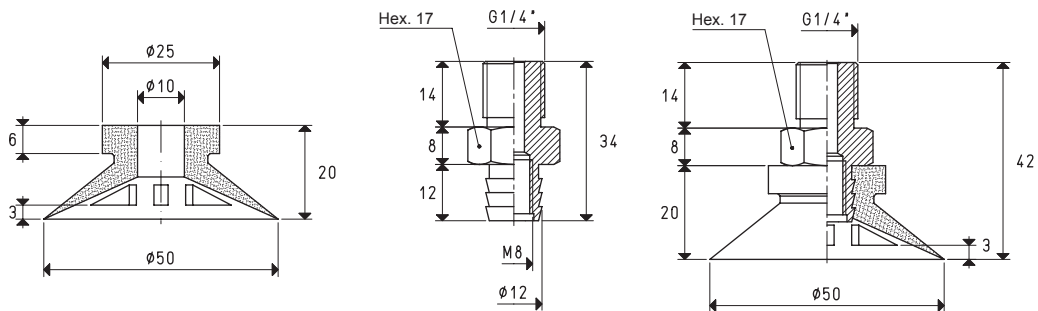

Cup Art.	Force Kg	Support Art.	Support material	Weight g	Cup with support Art.	Weight g
01 50 20 *	4.90	00 08 24	aluminium	10.3	08 50 20 *	20.3

\* Complete the code indicating the compound: A= oil-resistant rubber; N= natural para rubber; S= silicon

Conversion ratio: inch =  $\frac{mm}{25.4}$  ; pounds =  $\frac{g}{453.6} = \frac{Kg}{0.4536}$

GAS - NPT thread adapters available at page 1.117

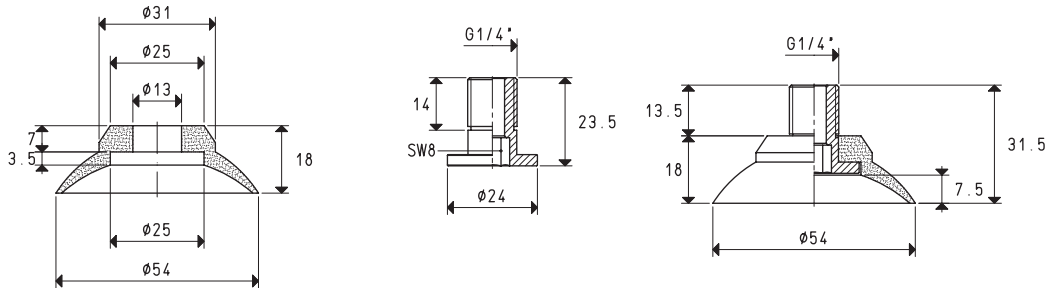

Cup Art.	Force Kg	Support Art.	Support material	Weight g	Cup with support Art.	Weight g
01 54 18 *	5.72	00 08 248	aluminium	5.8	08 54 18 *	16.4

\* Complete the code indicating the compound: A= oil-resistant rubber; N= natural para rubber; S= silicon

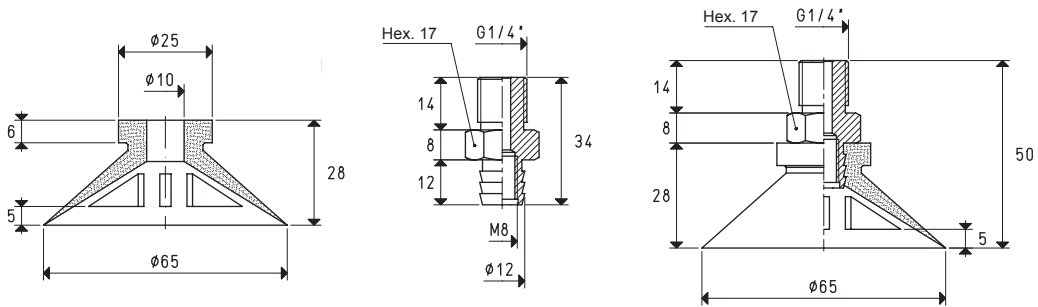

Cup Art.	Force Kg	Support Art.	Support material	Weight g	Cup with support Art.	Weight g
01 65 28 *	8.20	00 08 24	aluminium	10.3	08 65 28 *	26.0

\* Complete the code indicating the compound: A= oil-resistant rubber; N= natural para rubber; S= silicon

Conversion ratio:  $\text{inch} = \frac{\text{mm}}{25.4}$ ;  $\text{pounds} = \frac{\text{g}}{453.6} = 0.4536$

GAS - NPT thread adapters available at page 1.117