

Angular Gripper

SH Series

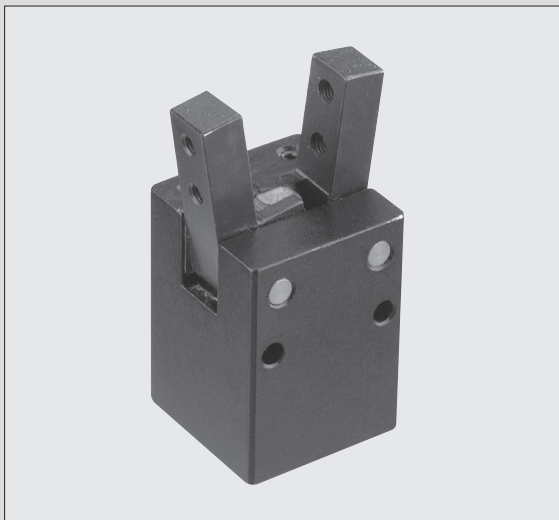

◆ Compact and Lightweight

This gripper is a compact rocking gripper.

Model Code No.

C SH - 16 C

Switch Type

C: With switch
 No code: Without switch
 (Mountable for $\phi 16$ only)

Series Name

Action Type

M: Single Acting Normally Open ($\phi 12$)
 A: Single Acting Normally Open ($\phi 16$)
 C: Double Acting ($\phi 16$)

Bore Size

12:12mm
 16:16mm

Internal Structure Diagram

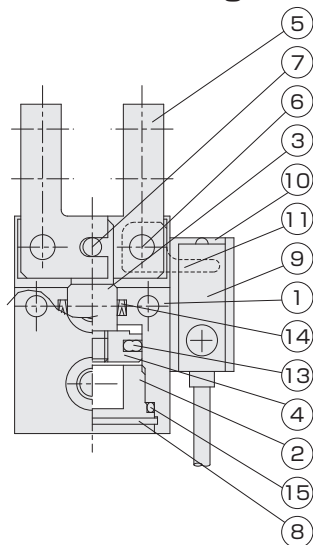

Parts List

NO	Name	Material
1	Main Body	Aluminum Alloy
2	Head Cover	12M: Iron 16: Brass
3	Piston Rod	Carbon Steel
4	Piston	Brass
5	Lever	Carbon Steel
6	Fulcrum Pin	Carbon Steel
7	Press Fit Pin	Carbon Steel
8	Hole Locating Snap Ring	Hard Steel
9	Switch	
10	Switch Mounting Plate	Resin
11	Switch Detection Plate	Iron
12	Spring	Spring Steel (Single Acting Type Only)
13	Piston Packing	NBR
14	Rod Packing	NBR
15	O Ring	NBR

Specifications

Fluid	Air
Maximum Operating Pressure [MPa]	0.7
Proof Pressure [MPa]	1.05
Operating Temperature [°C]	0~60 (No Freezing)
Lubrication	Not Required (Required for sliding parts of the machine)
Pipe Bore	M5×0.8
Maximum Operating Cycle [Cycle/min]	180
Applicable Switch	GX-F8A(Only CSH) See P.527

See the internal regulations for durability. This durability shall be used as a guide because durability largely changes depending on the gripper opening/closing speed, attachment weight, length and material, and chucking point, etc.

Action Type	Model	Bore Size [mm]	Minimum Operating Pressure [MPa]	Lever Screw	Gripping Force [N] ^{Note 1}		Outside Dimensions (T x W x L) [mm] ^{Note 2}	Product Mass [g]
					Close	Open		
Double Acting	SH-16C	16	0.1	M3×0.5 (x 4)	8	11	25×25×35	90
	CSH-16C	16	0.1	M3×0.5 (x 4)	8	11	25×35×35	105
Single Acting Normally Open	SH-12M	12	0.35	M3×0.5 (x 4)	2	—	20×20×27	39
	SH-16A	16	0.2	M3×0.5 (x 4)	6	—	25×25×35	90
	CSH-16A	16	0.2	M3×0.5 (x 4)	6	—	25×35×35	105

Note 1): L indicates the distance (cm) from the fulcrum pin to the grip point. This is an effective value when the pressure is 0.5 MPa.

Note 2): The outside dimensions indicate the main body dimensions. (Excluding the levers)

Effective Gripping Force (Closing Force)

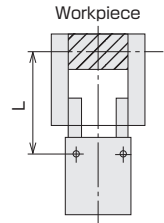
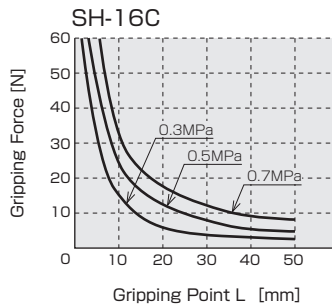
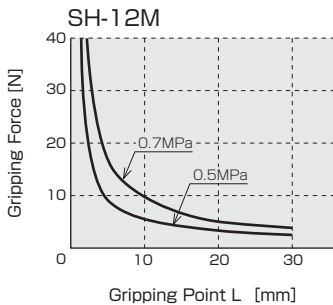

■ Dimensions SH-12M

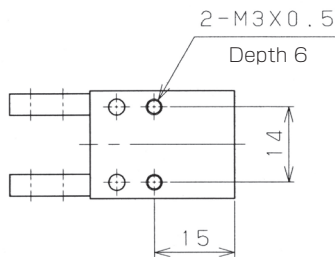
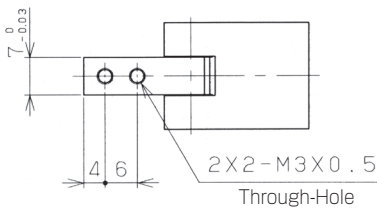
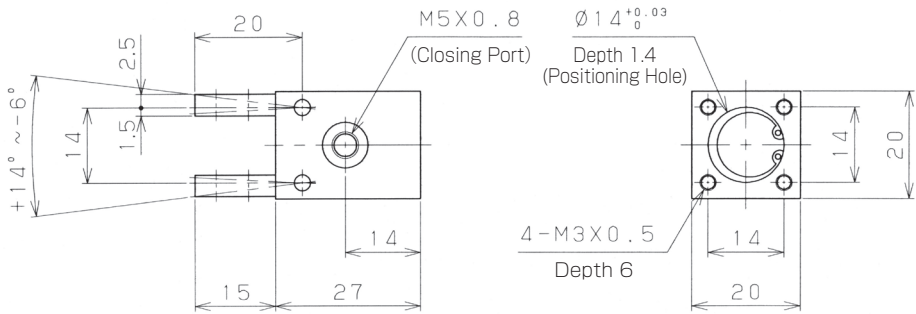

■ Dimensions **SH-16** □

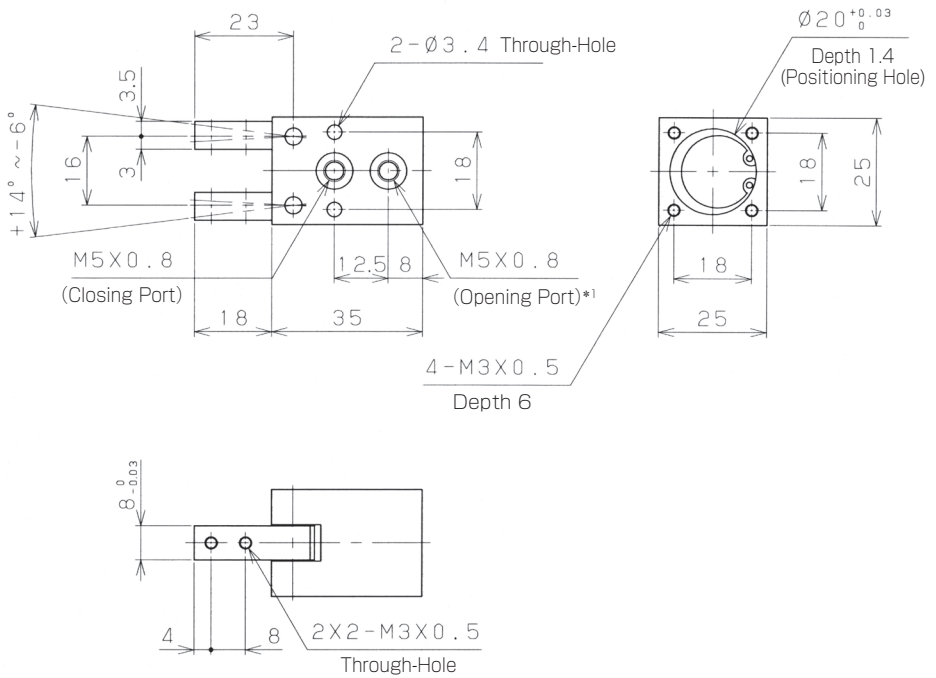

*1) For the single acting type, the opening port is used as the exhaust port.

■ Dimensions CSH-16

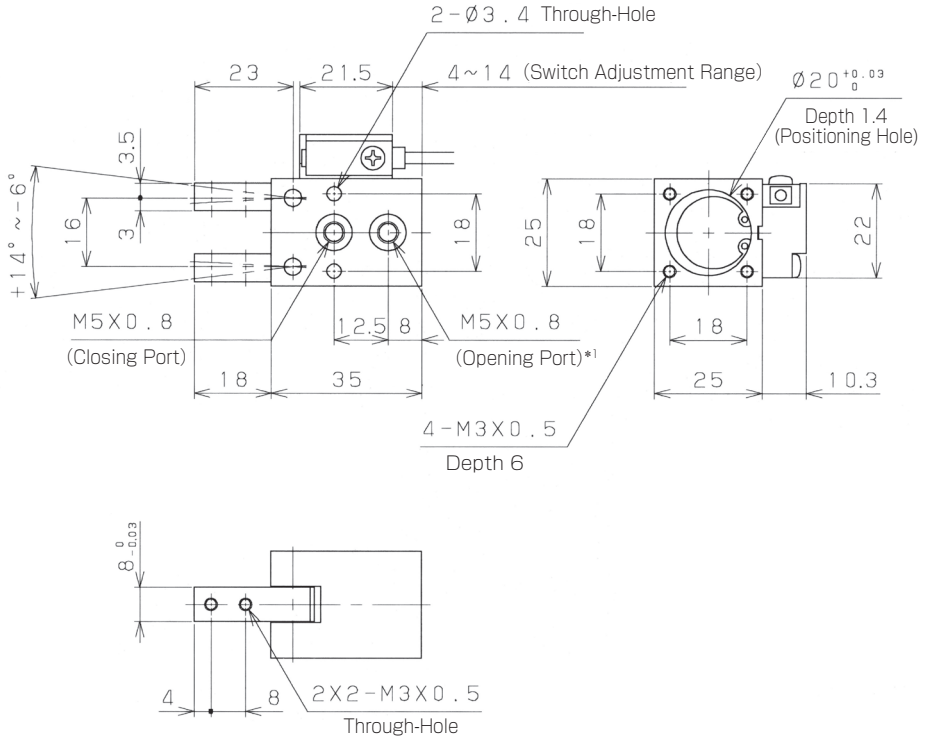

*1) For the single acting type, the opening port is used as the exhaust port.