

A•smoke^T Centralized Filter Units

The Absolent type A•smoke^T Oil smoke filter features one of the most effective systems in the world for cleaning oil mist and oil smoke. The series of central filter units consists of parallel modules which are dimensioned after the needed air-flow. A•smoke^T is designed for handling the most demanding applications, such as heat treatment. At the same time, maintenance is minimal. Let us explain to you how this amazing combination works!

The highest possible collecting efficiency.

The filtered air becomes so clean that it usually can be returned to the premises. This means less loss of energy and a more balanced ventilation.

Designed for oil smoke.

Oil smoke particles are very small, smaller than 1.0µm. Other filter types, such as centrifugal filters, have difficulties with small particles.

Extremely low maintenance.

Absolent filter units usually run for up to 6 years without filter change. This results in a low total cost of ownership.

A very reliable filter unit.

There are no moving components; this makes the filter unit very reliable. The external fan is to be placed at the clean-side to minimize wear & tear.

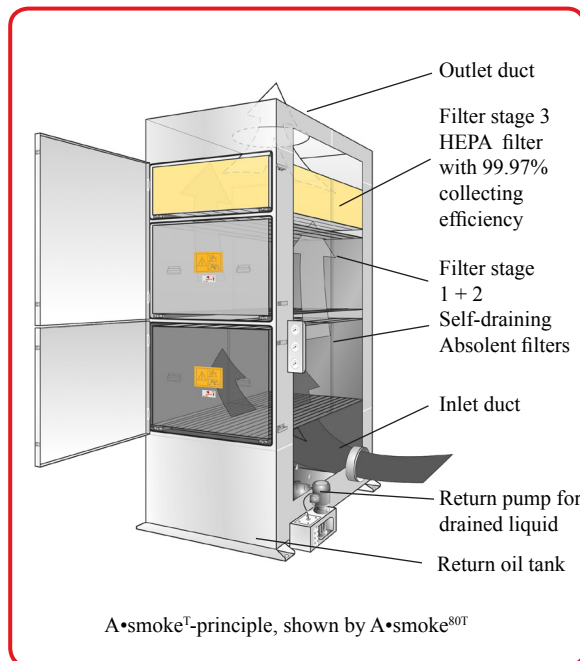
 A•smoke^{80T}

Operation

The filtering process occurs in three stages. The first and second stages consist of self-draining Absolent filter cassettes. Here, a minimum of 95% of the oil mist and smoke is arrested. The third stage consists of a HEPA-filter, which has a guaranteed and consistent collecting efficiency of 99.97% arresting 0.3µm dia. particles. Thanks to the continuous draining of the filter cassettes, the unit can be operated without interruptions. The return oil is collected at the bottom of the filter for recycling.

Range of Application

The Absolent A•smoke^T filter unit is well suited for use in applications such as:

- Heat treatment
- Cold-drawing
- Gear cutting
- Grinding with neat oil
- CNC turning with neat oil
- Forging operations and cold pressing

Design

The A•smoke^T contains an electronic manometer, which shows the filter unit's time of operation as well as the state of the filter cassettes. The unit has spacious doors for safe and easy service.

Principle lay-out (A•smoke^{160T})

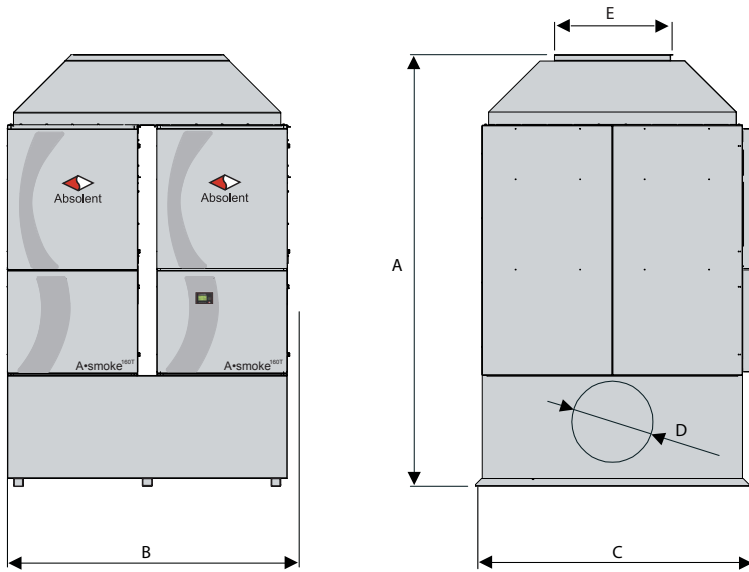

The filter unit has a central outlet as a standard. Side outlet upon request (for height see table underneath).

Unique filter cassettes



Absolent is one of few companies in this line of business that has specialized in the filtration of air containing wet particles. This has given us opportunity to develop a filter cassette that offers a long useful life with consistently high collecting efficiency.

Electronic manometer

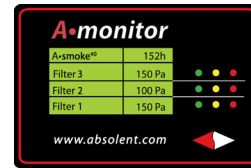

- Pressure drop and operation hour meters
- Optical indication of filter alarm (LED).
- Digital output signal for remote supervision.

Technical Data		A•smoke ^{80T}	A•smoke ^{160T}	A•smoke ^{240T}	A•smoke ^{320T}
Max. permissible air volume	[m ³ /h]	8000	1600	24000	32000
Weight (with clean filter cassettes)	[kg]	1430	2500	3900	5200
Height with centred outlet (A)	[mm]	2940	3348	3532	-
Height with side outlet (A)	[mm]	2944	-	3308	3905
Width (B)	[mm]	1153	2263	3428	4585
Depth (C)	[mm]	2115	2165	2165	2170
Rec. Inlet duct (D)	[mm]	ø400	ø630	710	900
Rec. Outlet duct (E)	[mm]	ø500	ø800	800	1960x740
Filter area filter 1 (Absolent filter)	[m ²]	48	96	144	192
Filter area filter 2 (Absolent filter)	[m ²]	51	102	153	204
Filter area filter 3 (HEPA-filter)	[m ²]	112,8	225,6	338,4	451,2

Filter units for bigger air flows can be supplied upon request.

Standard Equipment

- RAL 7035 fine structure SK3
Other colours on request!
- Electronic manometer for reading the pressure drop across the filter
- Lifting lugs

Accessories

- External fan unit
- Automatic starter
- Pump unit for drained liquid
- Control of pump equipment
- Frequency control of the fan with constant pressure control
- Duct connections for various types of steel or plastic ductwork available on the market
- Filter sledge for easier change of filter cassettes
- Special colour