



Line Vac

An INTELLIGENT COMPRESSED AIR® Product

Line Vac™

Convey parts, materials, waste - with no moving parts!

- ✓ High Conveying Rates!
- ✓ Ideal For Long Distance!
- ✓ Mounting Brackets Available!



What Is The Line Vac?

A fast, low cost way to convey:

- Plastic pellets
- Scrap/trim
- Textiles
- Bulk solids
- Food products
- Chips
- Paper
- Pills/tablets
- Small parts
- Shavings
- Sawdust
- Granules



Watch the demo!

www.exair.com/lvvideo.htm

EXAIR's compressed air operated Line Vac connects to standard hose or tube to create a powerful in-line conveyor. The compact design features large throat diameters for maximum throughput capability. Eleven sizes in aluminum and ten in stainless steel are suited to a wide variety of transfer applications.

Why The Line Vac?

Line Vac conveyors are ideal for moving large volumes of material over long distances. A small amount of compressed air is injected through directed nozzles to produce a vacuum on one end and high output flows on the other, with instantaneous response. The material flow rate is easily controlled with a pressure regulator. An optional bracket permits easy mounting. No moving parts or electricity assures maintenance free operation.



See page 4 for complete details.



A Model 6084 2" (51mm) Line Vac transports scrap cellophane trim to a waste barrel.



The Model 6083 1-1/2" (38mm) Line Vac conveys plastic granules to the gravity feed hopper on an extruder.

Applications

- Hopper loading
- Fiber tensioning
- Material conveying
- Waste/trim removal
- Chip removal
- Part transfer
- Filling operations

Advantages

- Compact
- Quiet
- No moving parts
- Fits standard hose or tube
- Aluminum or stainless steel
- Eleven sizes
- High throughput capability

How The Line Vac Works

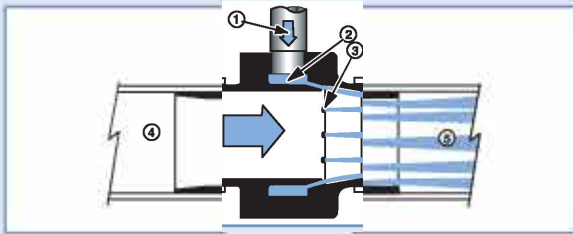

Compressed air flows through the inlet (1) into an annular plenum chamber (2). It is then injected into the throat through directed nozzles (3). These jets of air create a vacuum at the intake (4) which draws material in and accelerates it through the unit (5) for conveying over long vertical or horizontal distances.

Line Vac Conveying Rates

Line Vacs are available in a number of styles, materials, and sizes. Each has a large, smooth, straight bore that allows as much material to pass through as possible. Infinite control of the flow rate through the Line Vac can be controlled by a pressure regulator. Kits include a pressure regulator that is sized properly for flow.

The actual conveying rate is affected by the size, mass and geometry of the part to be conveyed along with the length, lift and number of bends in the hose, tube or pipe. These variables make it difficult to determine the exact conveying rate for any product, however, our Application Engineers can assist you by comparing the material you want to convey with something that has already been tested.



Line Vacs are available in many sizes in both aluminum and stainless steel.

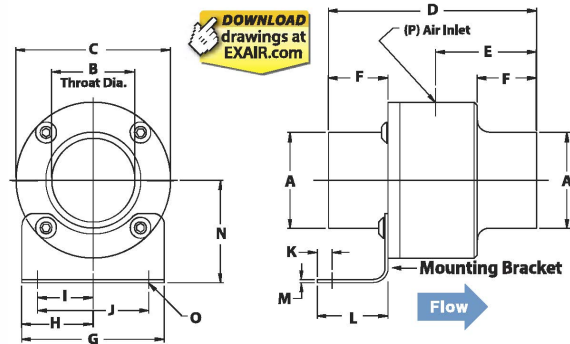

DOWNLOAD drawings at EXAIR.com

Line Vac Models			Line Vac Dimensions																	
Alum.	St. St.	Heavy Duty	Hose Size		A	B	C	D	E	F	G	H	I	J	K	L	M	N	O	P
6078	6058	N/A	in	0.38	0.19	1	2.18	1	0.63	1.25	0.62	0.41	0.82	0.17	1.13	0.06	1.07	0.18	1/8	
			mm	10	5	25	55	25	16	32	16	10	21	4	29	2	27	5	NPT	
6079	6059	N/A	in	0.50	0.31	1.25	2.62	1.23	0.75	1.25	0.63	0.34	0.68	0.13	1	0.06	1.18	0.18	1/8	
			mm	13	8	32	66	31	19	32	16	9	17	3	25	2	30	5	NPT	
6080	6060, 6060-316, HT6060, HT6060-316	150075	in	0.75	0.50	1.88	3.88	1.88	1	2	1	0.76	1.52	0.25	1.38	0.06	1.44	0.20	1/4	
			mm	19	13	48	99	48	25	51	25	19	39	6	35	2	37	5	NPT	
6081	6061, 6061-316, HT6061, HT6061-316	150100	in	1	0.75	2.13	3.88	1.88	1	2	1	0.65	1.30	0.26	1.32	0.06	1.56	0.20	1/4	
			mm	25	19	54	99	48	25	51	25	17	33	7	34	2	40	5	NPT	
6082	6062, 6062-316, HT6062, HT6062-316	150125	in	1.25	1	2.38	3.88	1.88	1	2.50	1.25	1	2	0.31	1.61	0.06	1.68	0.28	1/4	
			mm	32	25	61	99	48	25	64	32	25	51	8	41	2	43	7	NPT	
6083	6063, 6063-316, HT6063, HT6063-316	150150	in	1.50	1.25	2.75	4.38	2.13	1.25	2.50	1.25	0.86	1.73	0.25	1.44	0.06	1.88	0.28	3/8	
			mm	38	32	70	111	54	32	64	32	22	44	6	37	2	48	7	NPT	
6084	6064, 6064-316, HT6064, HT6064-316	150200	in	2	1.75	3.25	4.38	2.13	1.25	3	1.50	1.17	2.34	0.28	1.48	0.06	2.13	0.28	3/8	
			mm	51	45	83	111	54	32	76	38	30	59	7	38	2	54	7	NPT	
6085	6065, 6065-316, HT6065, HT6065-316	150250	in	2.50	2.25	3.75	4.38	2.13	1.25	3	1.50	1	2	0.31	1.44	0.06	2.38	0.28	3/8	
			mm	64	57	95	111	54	32	76	38	25	51	8	37	2	60	7	NPT	
6086	6066, 6066-316, HT6066, HT6066-316	150300	in	3	2.75	4.25	5.63	2.75	1.75	3.25	1.63	1.20	2.41	0.41	1.44	0.06	2.63	0.28	1/2	
			mm	76	70	108	143	70	45	83	41	31	61	10	37	2	67	7	NPT	
6087	6067	N/A	in	4	3.75	5.25	5.63	2.75	1.75	3.25	1.63	1.34	2.70	0.31	1.59	0.06	3.13	0.28	1/2	
			mm	102	95	133	143	70	45	83	41	34	69	8	40	2	80	7	NPT	
6088	N/A	N/A	in	5	4.75	6.25	5.63	2.75	1.75	4.13	2.06	1.70	3.47	0.33	1.52	0.06	3.63	0.28	1/2	
			mm	127	121	159	143	70	45	105	52	43	88	8	39	2	92	7	NPT	



Line Vac Performance

Model	80 PSIG (5.5 BAR)		Air Consumption		Vacuum	
	SCFM	SLPM	"H ₂ O	kPa		
6058, 6078	5.60	158	-120	-29.9		
6059, 6079	7	198	-100	-24.9		
6060, HT6060, 6060-316, HT6060-316, 6080	10.70	303	-72	-18		
6061, HT6061, 6061-316, HT6061-316, 6081	14.70	416	-42	-11		
6062, HT6062, 6062-316, HT6062-316, 6082	25.90	733	-42	-11		
6063, HT6063, 6063-316, HT6063-316, 6083	33	934	-36.8	-9		
6064, HT6064, 6064-316, HT6064-316, 6084	45	1,274	-28.5	-7		
NEW 6065, 6065-316, HT6065, HT6065-316, 6085	58.50	1,656	-23.5	-6		
NEW 6066, 6066-316, HT6066, HT6066-316, 6086	68.50	1,939	-14.7	-4		
6067, 6087	95	2,690	-13.6	-3.4		
6088	128	3,625	-10.5	-2.6		

Selecting The Right Model

Line Vac is available in a wide range of sizes to fit your application. Some of the criteria used to select the proper model are:

- Diameter of parts being conveyed
- Diameter of hose or tube
- Rate (weight or volume)
- Stainless steel (Type 303 and 316) or aluminum

Aluminum is the economical choice for general purpose conveying. Our standard stainless steel models (Type 303) offer good corrosion resistance and are ideal for food service, abrasive or corrosive applications. For critical applications including certain foods and pharmaceutical products, Type 316 stainless steel models provide excellent corrosion resistance.



A 316 Stainless Steel Line Vac is used by a pharmaceutical company to convey pills and tablets to a packaging station.



Line Vac Kits include a Line Vac, mounting bracket, filter separator and pressure regulator (with coupler).

Sound levels for the individual Line Vac units are not provided. The length, bends and configuration of the hose, tube or pipe used in conjunction with the Line Vac to form the complete conveying system will determine the actual sound levels (which can vary greatly).

Line Vac Comparison		
Material Type	Temperature Rating	Corrosion Resistance
Aluminum Line Vac	275°F (135°C)	Fair
Stainless Steel Line Vac (Type 303)	400°F (204°C)	Good
Stainless Steel Line Vac (Type 316)	400°F (204°C)	Excellent
High Temperature Stainless Steel Line Vac (Type 303)	900°F (482°C)	Good
High Temperature Stainless Steel Line Vac (Type 316)	900°F (482°C)	Excellent
Heavy Duty Line Vac Hardened Alloy Construction	400°F (204°C)	Good

The High Temperature Line Vac models are suited for temperatures up to 900°F (482°C). Frequently used for sampling hot flue gases, this High Temperature Line Vac can resist back pressure from long pipe lengths with numerous bends. The Heavy Duty Line Vac shown on page 136 moves the highest volumes and resists wear.



High Temperature Line Vacs can resist temperatures to 900°F (482°C) and are available from stock in hose or threaded models.

Clear PVC Hose

EXAIR stocks 3/8" (10mm), 1/2" (13mm), 3/4" (19mm), 1" (25mm), 1-1/4" (32mm), 1-1/2" (38mm), 2" (51mm), 2-1/2" (64mm) and 3" (76mm) I.D. PVC hose in lengths up to 50' (15.2m). Ideal for conveying applications, the hose is very flexible and has a smooth internal bore that eliminates material build up. The reinforced, heavy wall of this clear hose provides visual confirmation that the material is moving when air is supplied to the Line Vac. Temperature rating is -4 to 150°F (-20 to 66°C).



Special Line Vacs

EXAIR manufactures special Line Vacs suited to specific application requirements. Configurations and materials can be made to facilitate your requirements.

The Line Vac can be engineered to retrofit existing machinery. The Line Vac (*shown below*) has special flanges that permit direct mounting to a machine used in the manufacturing of silicon wafers for the semiconductor industry.



A special 3/4" (19mm) Stainless Steel Line Vac evacuates fumes from a silicon wafer etching operation.

This flanged Line Vac is used to remove acidic vapors resulting from surface etching of the silicon wafer. Ordinarily, EXAIR's Stainless Steel Air Amplifier would have been used since it moves much higher volumes of air. In this case, the Line Vac was the better choice since the exhaust piping was long with many bends that would have created high back pressure. The directed nozzles of the Line Vac overcame this downstream resistance.



This special 1-1/2" (38mm) Line Vac is made of PVDF to withstand a chloride washdown.

The special flanged Line Vac (*shown above*) is made of PVDF, a plastic that has high chemical resistance. In this case, the 1-1/2" (38mm) Line Vac was regularly exposed to a chloride wash, a chemical that would corrode stainless steel. QF flanges were provided on each end to allow easy removal of the conveying hoses for cleaning purposes.



This special Line Vac is used to fill small packets.

Filling small packets with fine powders or granulated materials

If you have special requirements, please contact an Application Engineer to discuss the application.

such as salt or sugar is done using small tubes that are gravity fed from a hopper. This works well when the material is dry, however, moist materials would often pack the tube, blocking the flow. The special funnel shaped Line Vac (*shown bottom center*) created a suction on the existing tube to permit continuous product flow.



A special miniature Line Vac used to vacuum microscopic debris measures the same size as a penny!

The special miniature Line Vac with barb fittings (*shown above*) was designed for a manufacturer of integrated circuit chips. It was used to remove microscopic debris during the chip making process. This small Line Vac generated high vacuum and was the perfect configuration for the confined working space. It has also been used by another manufacturer to vacuum liquid and chips from small drilled holes.

Refilling A Vibratory Bowl

The Problem: A manufacturer of metal products deburrs aluminum sleeves in a vibratory bowl filled with abrasive media. As the parts complete the deburring cycle, they are discharged to a screened bed. The abrasive media drops through the bed and the finished parts roll into a box. Refilling the bowl was a back breaking operation that required repetitious lifting of heavy buckets.

The Solution: A **Model 6064 2" (51mm) Stainless Steel Line Vac** was installed on the vibratory bowl. In minutes, the media was conveyed back up to the bowl through a hose, without the heavy lifting.

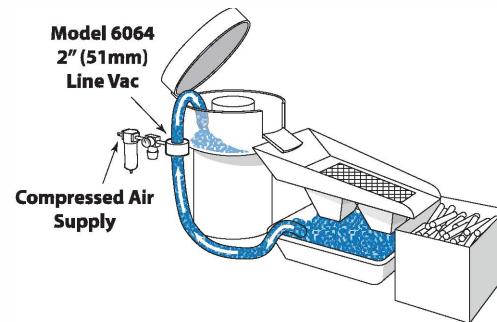

Comment: The ability to convey the abrasive media with air was the key to success. The Line Vac is easy to use, and in this case, was the best choice since it will hold up better to the abrasive media conveyed through it.

Conveying Plastic Pellets

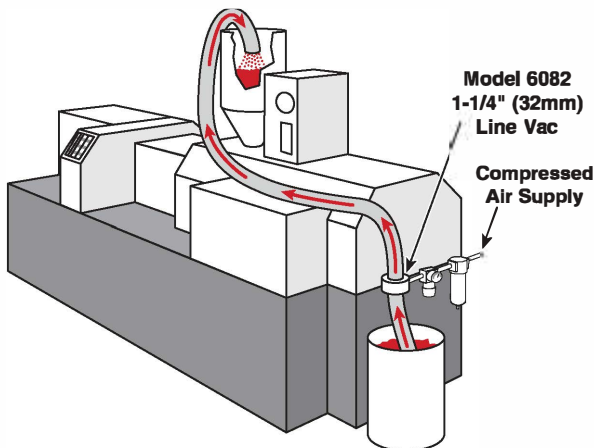

The Problem: Injection molding machines transform plastic pellets into various plastic products. The pellets are gravity fed from a hopper on top of the machine. The “bucket and ladder” method of replenishing the hopper was inefficient and expensive.

The Solution: A **Model 6982 1-1/4" (32mm) Line Vac Kit** was used to convey the pellets up to the hopper. The mounting bracket included with the kit was used to secure the Line Vac to the machine. A filter assured no contamination of the plastic material and a regulator controlled the plastic flow rate.

Comment: Unlike mechanical transfer systems that break down or wear out, the **Line Vac has no moving parts**. This low cost method of conveying also gives precise control of material flow into the hopper.

Line Vac for Matrix Removal from Labelling Application

The Problem: A manufacturer applies labels to their products. After they have been applied, there is a waste stream that is referred to as “the matrix”. The matrix is the release liner that labels are affixed to in bulk format prior to being used. The normal method for taking up this waste stream was to use a winder. However, after some amount of time, the winder inevitably becomes filled. Once full, the line is stopped and the winder is manually emptied. They needed a better way to dispose of the matrix.

The Solution: The **Line Vac** presents a unique advantage in that it can pull the matrix from the machine and convey it out to a waste receptacle. This requires no winder, no stopping the line and no emptying. This solution freed up personnel for other tasks and increased production. The compact design and powerful operation of the Line Vac

allowed it to be placed close to the generation of scrap, trim, or waste. Its powerful conveying capacity allowed it to transport the material to a remote and central location.

Comment: This application illustrates the versatility of the Line Vac product line. Commonly used for hopper loading products in the plastics industry, a Line Vac is also a strong performer for applications like waste/trim removal, assembly parts conveyance, blasting media recovery, gas sampling and chip removal. Its large variety of materials and sizes makes it well suited for industrial, pharmaceutical, laboratory, high temperature and corrosive environments. No moving parts or electricity assures maintenance free operation.



1" (25mm) Line Vacs remove and discard a label matrix.

Line Vac Only Models

Inlet/Outlet Diameter	Aluminum Line Vac Model	Type 303 Stainless Steel Line Vac Model	Type 316 Stainless Steel Line Vac Model	High Temperature Type 303 Stainless Steel Line Vac Model	High Temperature Type 316 Stainless Steel Line Vac Model
3/8" (10mm)	6078	6058	N/A	N/A	N/A
1/2" (13mm)	6079	6059	N/A	N/A	N/A
3/4" (19mm)	6080	6060	6060-316	HT6060	HT6060-316
1" (25mm)	6081	6061	6061-316	HT6061	HT6061-316
1-1/4" (32mm)	6082	6062	6062-316	HT6062	HT6062-316
1-1/2" (38mm)	6083	6063	6063-316	HT6063	HT6063-316
2" (51mm)	6084	6064	6064-316	HT6064	HT6064-316
2-1/2" (64mm)	6085	6065	6065-316	HT6065	HT6065-316
3" (76mm)	6086	6066	6066-316	HT6066	HT6066-316
4" (102mm)	6087	6067	N/A	N/A	N/A
5" (127mm)	6088	N/A	N/A	N/A	N/A

NEW
NEW

Line Vac Kit Models

Line Vac Kits - include the Line Vac, mounting bracket, filter separator and pressure regulator (with coupler).

Inlet/Outlet Diameter	Aluminum Line Vac Kit Model	Type 303 Stainless Steel Line Vac Kit Model	Type 316 Stainless Steel Line Vac Kit Model	High Temperature Type 303 Stainless Steel Line Vac Kit Model	High Temperature Type 316 Stainless Steel Line Vac Kit Model
3/8" (10mm)	6978	6958	N/A	N/A	N/A
1/2" (13mm)	6979	6959	N/A	N/A	N/A
3/4" (19mm)	6980	6960	6960-316	HT6960	HT6960-316
1" (25mm)	6981	6961	6961-316	HT6961	HT6961-316
1-1/4" (32mm)	6982	6962	6962-316	HT6962	HT6962-316
1-1/2" (38mm)	6983	6963	6963-316	HT6963	HT6963-316
2" (51mm)	6984	6964	6964-316	HT6964	HT6964-316
2-1/2" (64mm)	6985	6965	6965-316	HT6965	HT6965-316
3" (76mm)	6986	6966	6966-316	HT6966	HT6966-316
4" (102mm)	6987	6967	N/A	N/A	N/A
5" (127mm)	6988	N/A	N/A	N/A	N/A

Air Operated
Conveyors

NEW
NEW

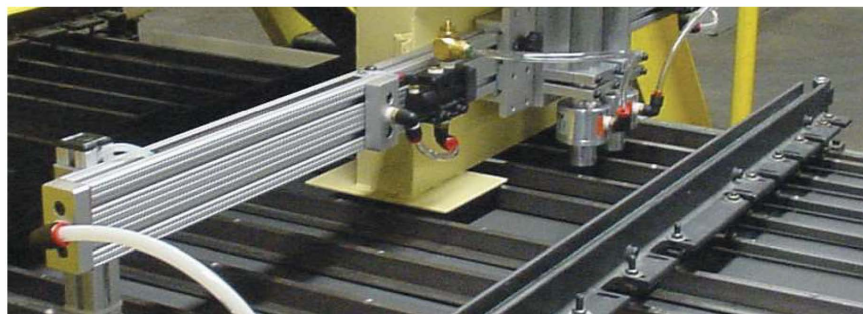

(2) Model 6083 1-1/2" (38mm) Line Vacs convey rejected metal caps from a fluorescent lamp operation to a scrap bin.

Accessories

Model #	Description
6994	Mounting Bracket for 3/8" (10mm) and 1/2" (13mm) Line Vac Units
6995	Mounting Bracket for 3/4" (19mm) and 1" (25mm) Line Vac Units
6996	Mounting Bracket for 1-1/4" (32mm) and 1-1/2" (38mm) Line Vac Units
6997	Mounting Bracket for 2" (51mm), and 2-1/2" (64mm) Line Vac Units
6998	Mounting Bracket for 3" (76mm) and 4" (102mm) Line Vac Units
6999	Mounting Bracket for 5" (127mm) Line Vac Unit
9001	Auto Drain Filter Separator, 3/8 NPT, 65 SCFM (1,841 SLPM)
9032	Auto Drain Filter Separator, 1/2 NPT, 90 SCFM (2,549 SLPM)
9002	Auto Drain Filter Separator, 3/4 NPT, 220 SCFM (6,230 SLPM)
9005	Oil Removal Filter, 3/8 NPT, 15-37 SCFM (425-1,048 SLPM)
9006	Oil Removal Filter, 3/4 NPT, 50-150 SCFM (1,416-4,248 SLPM)
9008	Pressure Regulator with Gauge, 1/4 NPT, 50 SCFM (1,416 SLPM)
9033	Pressure Regulator with Gauge, 1/2 NPT, 100 SCFM (2,832 SLPM)
9009	Pressure Regulator with Gauge, 3/4 NPT, 220 SCFM (6,230 SLPM)

Hose is available in 10', 20', 30', 40' and 50' lengths. Select the hose model number (diameter) and indicate the length with a dash. Example: A Model 6931-20 is 1" ID Hose x 20' long.

6928-	Hose 3/8" ID
6929-	Hose 1/2" ID
6930-	Hose 3/4" ID
6931-	Hose 1" ID
6932-	Hose 1-1/4" ID
6933-	Hose 1-1/2" ID
6934-	Hose 2" ID
6935-	Hose 2-1/2" ID
6936-	Hose 3" ID



1-1/4" (32mm) Line Vac is mounted on a burr removal tool to suction the plastic shavings and transport them to a waste container.