

AVS



mecair MCS

128 OUTPUT DEMAND CONTROLLER

PENTAIR CLEAN AIR SYSTEMS

MECAIR 128 OUTPUT DEMAND CONTROLLER

MCS

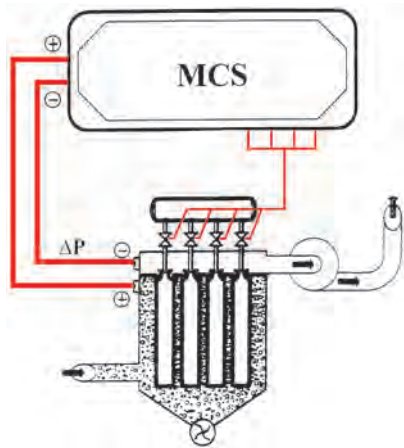

DESCRIPTION

The economist model "MCS" uses advanced microprocessor technology, expressly designed to control the interval and the pulse time of diaphragm valves using the DP and focusing on reverse pulse-jet systems with pneumatic cleaning procedures. All the technical characteristics satisfy the "CE" Directives which relate to isolation and low voltage power. The unit has been tested by an authorised institute and is in conformity with the European Regulation 89/336 EEC and 93/68 EEC.

Upon request it is possible to supply the unit in accordance with the European Directive EC/94/9 ATEX, ATEX II 3D (zone 22).

The MCS is available with a minimum of 4 outlets (MCS4) up to a maximum of 128 outlets (MCS128).

The intermediate models increment in multiples of 4 (MCS4, MCS8, MCS12, etc.).

The principle of the MCS is as follows: an internal sensor registers the progress of the DP in the filter and when it exceeds the value of the set DP, the unit automatically sends a signal to the diaphragm valves in sequence (skipping the outlets which are not connected or where there is no charge recognised). The unit also allows you to set the MANUAL CYCLE TIME (this is the time it takes for all the valves to complete an entire cleaning cycle). This way you obtain the automatic regulation of the Pause Time between one valve and the next. All this is possible thanks to a sophisticated algorithm, which is able to automatically optimise the Pause Time, starting from the set Manual Cycle Time. On the digital display of the unit, you are able to

identify all the operating values, such as the Set DP, DP Alarm, Pause Time, Hour Counter, number of cycles for Shut Down Cleaning and the relative Pause Time.

The Economist also has the PRECOATING function, which subordinates the start of the cleaning cycle until such time as a preset DP value for PRECOATING has been reached (this DP value has to be greater than the Set DP). This allows the filtering elements to overload with reagents and preparation powders. It is possible to set an independent value for the DP ALARM as well.

MAIN FEATURES

- Timed sequential control of the electronic valves with zero-crossing to eliminate electrical interference.
- Short-circuit alarm, microprocessor malfunction alarm and alarm of exceeded DP.
- Regulation of the set DP, pulse time, number of cycles in final cleaning, with indication on the display.
- Setting of the MANUAL CYCLE TIME (this is the time it takes for all the valves to complete an entire cleaning cycle).
- PRECOATING function (start of the cleaning sequence subordinated to the achievement of the DP PRECOATING), for filters that have to be overloaded with reagents and preparation powders.
- Easy predisposition outlets voltage (AC/DC) and inlet voltage (AC).
- Automatic system for the command of one or more cycles for the final cleaning.
- Hour counter (indicates the number of hours which the filter has actually worked – from 0 to 9999 hours).

MECAIR 128 OUTPUT DEMAND CONTROLLER

MCS

DIMENSIONS

DIMENSIONS MCS 4 to 32 outlets (mm)

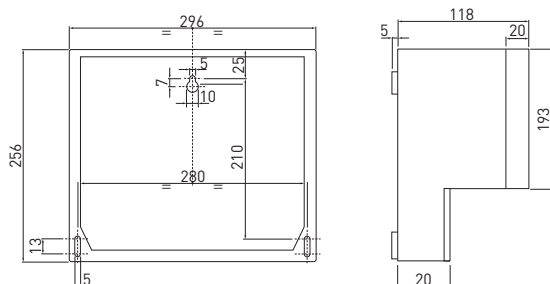

DIMENSIONS MCS 36 to 64 outlets (mm)

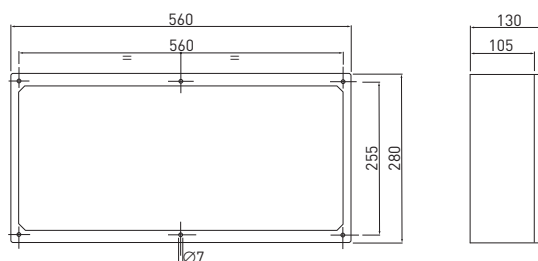

DIMENSIONS MCS 64/128 outlets (mm)

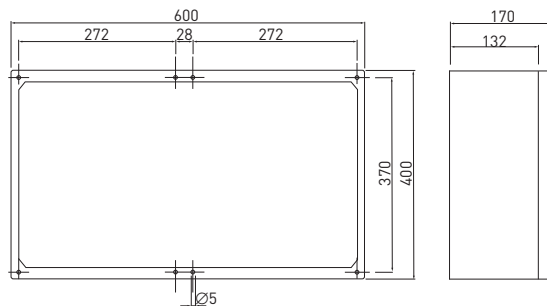

TECHNICAL CHARACTERISTICS

Enclosure	ABS grey – transparent cover	
Protection rating	IP65	
Dimensions	MCS 4–32: enclosure 296 × 256 × 118 MCS 36–64: enclosure 560 × 280 × 130 MCS 68–128: enclosure 600 × 400 × 170	
Connections	Push-in plugs – with max. wire section of 2.5 mm ²	
Temperature	Storage: –20°C/+80°C Operating: –10°C/+50°C	
Weight	MCS32: approx. 3.3 kg MCS48: approx. 7 kg MCS128: approx. 9.1 kg	
Power supply	Standard: 115–230 V (±10%) – 50/60 Hz (AC/DC)	Optional: 24 V DC/24 + 48 V (±10%) – 50/60 Hz
Outlets	Standard: 4-115-230 V (3 ranges available via selection of plugs) IN – OUT 24 V AC	Optional: 48 V AC
Number of outlets	Min. 8 – Max. 128 (intermediate models are available in multiple of 4)	
Power	Input power: max. 2.5 VA	Output power: max. 25 VA/AC – 20 Watt/DC, with maximum pulse time 1 sec.
Pulse time	0.01–9.99 sec.	
Manual cycle time	1–999 sec.	
Set ΔP	0.01–9.99 kPa	
Set ΔP alarm	0.01–9.99 kPa	
Precoating	0–9.99 kPa	
No. cycles in final cleaning	0–99 times	
Hour counter	0–65.999 hours	

AVS



CLEANAIRSYSTEMS.COM

© 2014 Pentair Clean Air Systems reserves the right to change product designs and specifications without notice.

Mecair 128 Output Demand Controller EU Compliant Rev02.02/15