



PRESSURE ACTUATED SWITCHES148

ELECTRIC & PNEUMATIC SWITCHES149

PRESSURE REGULATORS150

EXPANDED! CHECK VALVES151 - 152

EXPANDED! NEEDLE VALVES153 - 156

MUFFLERS154

EXPANDED! FLOW CONTROLS157 - 161

SHUTTLE VALVES162 - 163

EXHAUST VALVES164 - 165

PULSE VALVE LEAK DETECTOR166

SPECIALTY COMPONENTS167 - 168

PNEUMATIC COUNTERS169

SENSORS170 - 171

SPECIAL FUNCTION VALVES172 - 174



Medium: Air
Inlet Pressure: 5 to 150 psig
Pilot Port: #10-32, 1/8" NPT



Mounting: External thread and nut for panel, bracket, or bulkhead mounting,
 5/8 - 32 pressure actuated
 #15/32-32 manually operated

Accuracy: Actuation pressures listed are nominal values only. For applications where a tight tolerance for actuation or deactuation is needed, please contact Clippard.



SAS Sub-Miniature Air Switch
MAS Miniature Air Switch

Design Series

Switch Current Rating:

- SAS**
A 5A @ 125/250 VAC
 3A @ 30 VDC/.1A 60 VDC
X no switch

MAS

- B** 3A @ 125/250 VAC
 3A @ 30 VDC
C 10A @ 125/250 VAC
 5A @ 50 VDC

Switch Terminals:

- SAS:** **0** no switch
1 110 series Q.C.

- MAS:** **0** no switch
2 187 series Q.C.
3 screw terminals

Nominal Actuation Pressure*

- 06** 6 psig
20 20 psig
40 41 psig
65 65 psig
MN Manual

Inlet Port:

- Blank** #10-32 thd
F 1/8" NPT female
P 1/8" NPT male

*Actuation pressure is nominal only. For applications where accuracy is critical, please contact Clippard.

Pressure Actuated

Mechanically Actuated

SAS Model

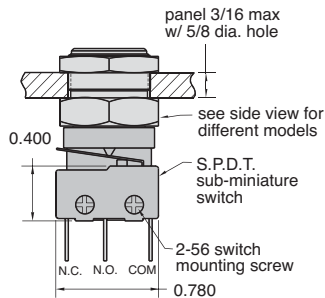

STD. & -M5

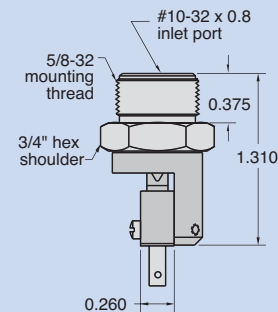

-F & -P

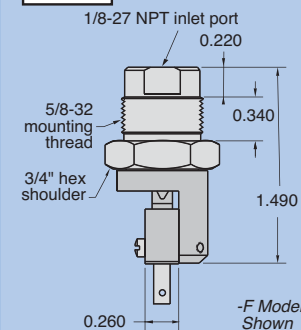

-MN

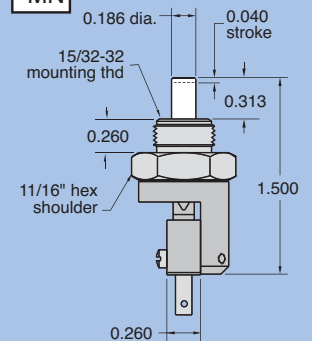

MAS Model

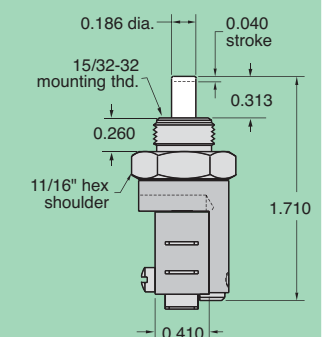
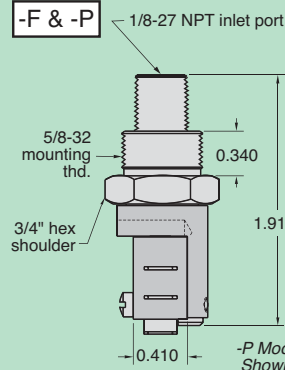
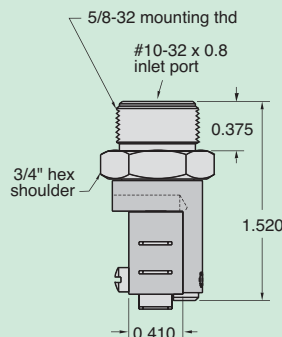
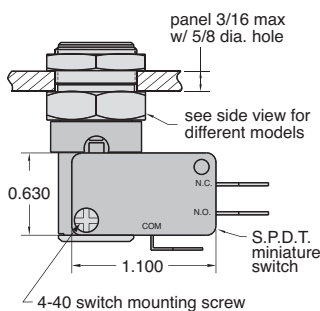

Single Pole Electrical Switch

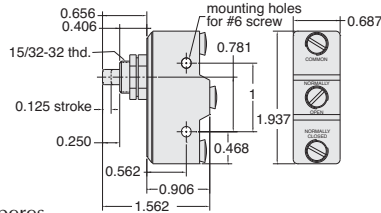

Stem Travel: 1/8" (3.2)

Rating A.C.: 120 volts - 15 amperes
240 volts - 15 amperes
480 volts - 15 amperes

Rating D.C.: 125 volts - 0.5 amperes
250 volts - 0.25 amperes



Mounting: #15/32-32 thread; nut and lockwashers furnished, also two 0.140" dia. mounting holes in body

Approvals: UL and CE

Part No.	Description
ES-1	Single Pole, Double Throw Snap-Action Electrical Switch
15601	Terminal Cover

Pneumatic Electric Switches

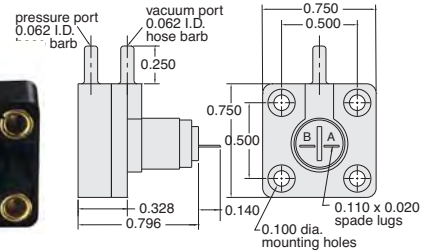

Electrical Rating: 60 ma. AC resistive 40 ma. DC resistive @ 120 volts

Switching Speed: 125 Hz, Normally-Open

Actuating Pressure: 3" H₂O 10% pressure vacuum, or DP

Maximum Pressure: 8 psig (continuous)

Construction: ABS plastic case gold plated contacts natural rubber diaphragm

Use: For interfacing fluidic or other low pressure air signals with Electronic circuitry dual inputs operates on pressure, vacuum, or differential pressure signals

[View additional information and useful videos](#)

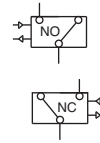

Part No.	Description
5100-3-NO	Pneumatic Electric Switch, Normally-Open Contacts
5100-3-NC	Pneumatic Electric Switch, Normally-Closed Contacts

CUSTOMer solutions

If you need a product that fits your application perfectly, Clippard has the capability to design or modify one of its products to suit your exact needs. We understand that a standard catalog product may be close but not be exactly what you need. Let us know YOUR Need, and we will help to find YOUR Solution!



Needle valves are common in controlling the flow of fluids and gases. This special needle valve uses a "D" stem for adapting to standard panel knobs. It also incorporates a special left-handed thread to provide a more intuitive clockwise movement to increase flow of the back for ease-of-assembly in a tight space. It also incorporates a special toggle to match the customers' aesthetic requirements.

A combination assembly using a toggle or push button operator and Clippard's pressure-actuated electrical switches provides a simultaneous air and electrical output.



This air-piloted valve is designed for a water application where limited space is available.



Alternate materials, seals and/or lubrication for specific applications are common (and welcomed) requests at Clippard. Stainless steel, aluminum, plastic or brass. All available, just ask!

For more information, visit www.clippard.com/customsolutions

Miniature Pressure Regulators

Regulators are offered in either relieving or non-relieving versions. The relieving design maintains a constant pressure output even when downstream conditions change.

The non-relieving regulator does not automatically compensate for changes in downstream flow or pressure. There is no vent to atmosphere, as in a relieving type regulator, and the output pressure can increase due to a downstream event.

Medium: Air

Materials: Brass body, Nitrile seals, stainless steel stem and spring

Air Flow: 3 scfm @ 50 psig; 5 scfm @ 100 psig

Input Pressure: 300 psig

Mounting: #15/32-32 thread. Nuts and lockwashers furnished

Adjustment: By means of a knob with micro-adjustment (40 pitch thd.)



Adjustable Pressure Regulators

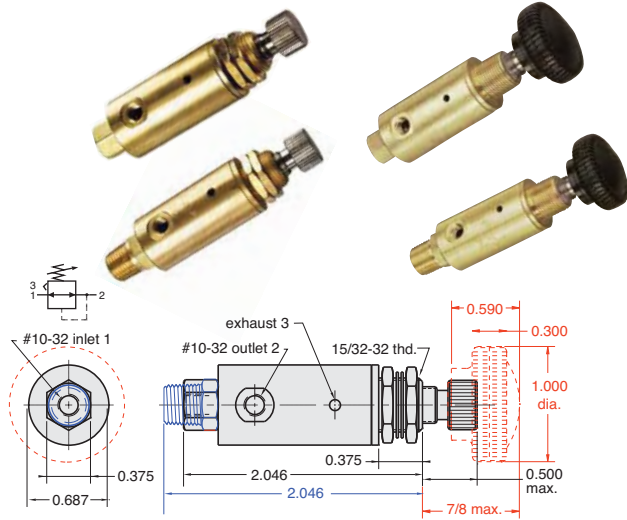

All **NEW** mounting configurations now available. See updated product specifications [here](#).

Plunger-Type Pressure Regulators

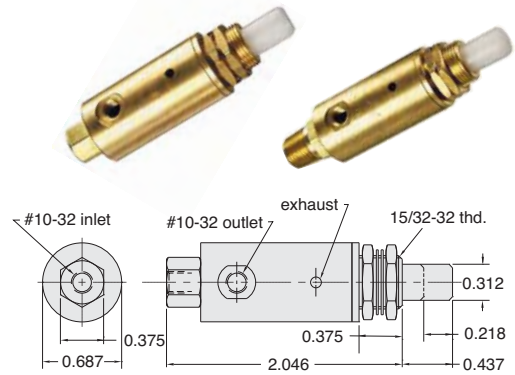

Plunger Travel: 7/32"

Force For Full Stem Travel: 25 lb. nominal

Operation: As plunger is depressed pressure increases proportionally to the travel; when plunger is released the input is closed and the output pressure is exhausted to atmosphere

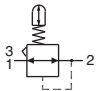

Range (psig)	#10-32	Knob	1/8" NPT	Non-Relieving
0-20	MAR-1-2	MAR-1K-2	MAR-1P-2	
0-30	MAR-1-3	MAR-1K-3	MAR-1P-3	MAR-1NR-3
0-40	MAR-1-4	MAR-1K-4	MAR-1P-4	MAR-1NR-4
0-50	MAR-1-5	MAR-1K-5	MAR-1P-5	MAR-1NR-5
0-60	MAR-1-6	MAR-1K-6	MAR-1P-6	MAR-1NR-6
0-70	MAR-1-7	MAR-1K-7	MAR-1P-7	MAR-1NR-7
0-100	MAR-1	MAR-1K	MAR-1P	MAR-1NR

Range (psig)*	#10-32	1/8" NPT
0-20	MAR-1C-2	MAR-1CP-2
0-30	MAR-1C-3	MAR-1CP-3
0-40	MAR-1C-4	MAR-1CP-4
0-50	MAR-1C-5	MAR-1CP-5
0-60	MAR-1C-6	MAR-1CP-6
0-70	MAR-1C-7	MAR-1CP-7
0-100	MAR-1C	MAR-1CP

Cartridge and manifold mount styles also available. Consult factory.

* Outlet pressure is based on 7/32" stem travel. If stem is depressed further, the outlet pressure will increase.

MAR Series Regulators

Special Configurations & Assemblies

- Robust
- Reliable
- Manifold Mount
- Pre-Assembled & Tested
- Compact
- Multiple Medias
- Cartridge Style
- Preset to Pressure

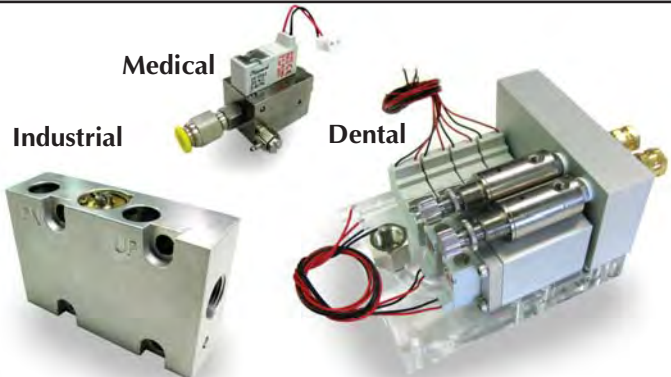



Four varieties of check valves are offered by Clippard. Each permits flow in one direction only. All have bright-dipped brass bodies that provide in-line mounting, Nitrile seals and stainless steel springs as standard. The MCV-2 has #10-32 ports and a "duck-bill" seal. The MCV-1 series has #10-32 ports and a brass poppet. The MJCV-1 series has 1/8" NPT ports and a Zytel 80G33 poppet. The GCV has 1/4" and 3/8" NPT ports.

Materials: Brass body, Nitrile seals, stainless steel spring

Medium: Air or Hydraulic

Input Pressure: 300 psig max. (MJCV Series: 1,000 psig hydraulic max.)

Pressure To Open: Cracks at approx. 1/2 psig

Mounting: Direct or in-line

Flow Direction: Arrow on valve body indicates direction of flow

Temperature Range: 32° to 230°F

Note: Not intended for pressure relief



Medium: Air
Input Pressure: 100 psig
Air Flow: 1 scfm @ 50 psig

Part No.
MCV-2

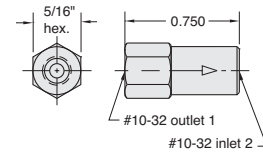

Pressure To Crack: 1 psig
Pressure To Fully Open: 2.5



Part No.
MCV-1AB

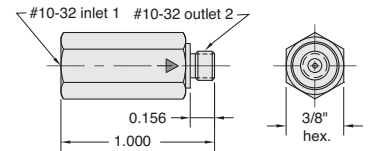

Air Flow: 6.5 scfm @ 50 psig; 11.5 scfm @ 100 psig



Part No.
MCV-1BB

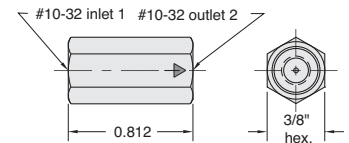

Air Flow: 6.5 scfm @ 50 psig; 11.5 scfm @ 100 psig



Part No.
MICV-1AB

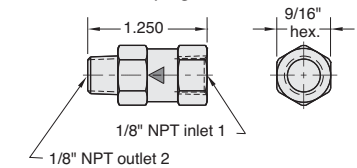

Air Flow: 20 scfm @ 50 psig; 36 scfm @ 100 psig



Part No.
MICV-1BA

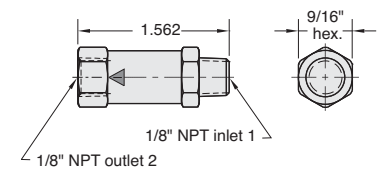

Air Flow: 20 scfm @ 50 psig; 36 scfm @ 100 psig



Part No.
MCV-1

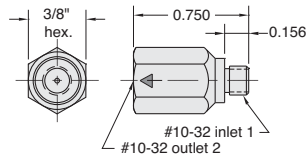

Air Flow: 6.5 scfm @ 50 psig; 11.5 scfm @ 100 psig



Part No.
MCV-1AA

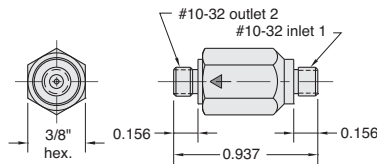

Air Flow: 6.5 scfm @ 50 psig; 11.5 scfm @ 100 psig



Part No.
MICV-1

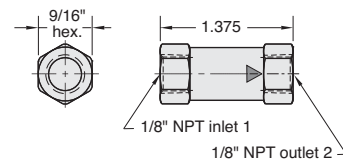

Air Flow: 20 scfm @ 50 psig; 36 scfm @ 100 psig



Part No.
MICV-1AA

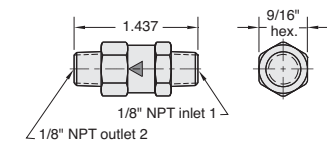

Part No.
GCV-4

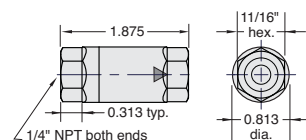

Pressure To Crack: 1.5 psig

Air Flow: 39 scfm @ 50 psig; 70 scfm @ 100 psig



Part No.
GCV-5

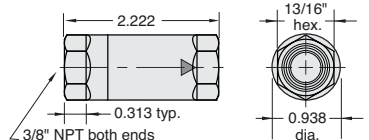

Pressure To Crack: 1.5 psig

Air Flow: 84 scfm @ 50 psig; 150 scfm @ 100 psig



Pilot-Operated Check Valves work as standard check valves, but can be opened with an air pilot signal to permit free flow in the normally “checked” direction. The Clippard Pilot-Operated Check Valve provides the user with a reliable method to check flow in one direction, with the ability to remotely signal a free flow through the valve. Ideal for any circuit that requires this useful function—all in one valve that is easy to connect!

- High flow valve means low pressure drop
- Uses Clippard’s superior poppet design
- Variety of port configurations available
- “Auxiliary” port allows ease of plumbing
- Side port (port 2) rotates for ease of positioning

Medium: Air, Water or Oil
Pressure Range: Up to 300 psig (see chart below)
Temperature Range: 32 to 230°F
Materials: ENP brass, anodized aluminum, stainless steel, Nitrile seals



For specialty options such as various seal materials, manual override, or specific pilot to supply ratios, please consult factory.

Function/Porting Options

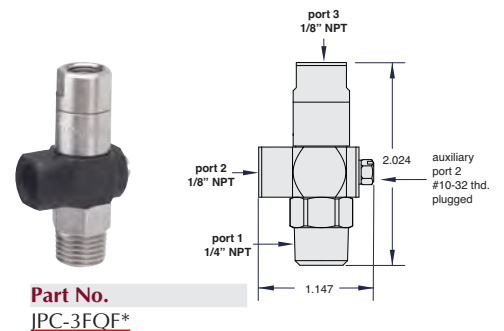
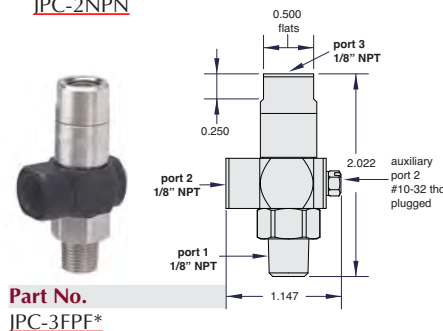
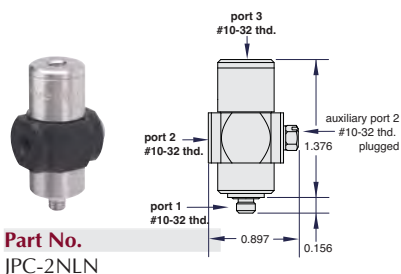
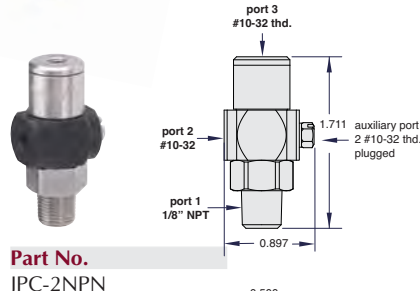
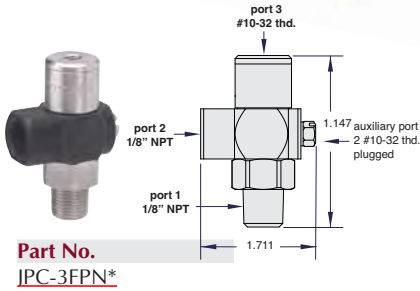
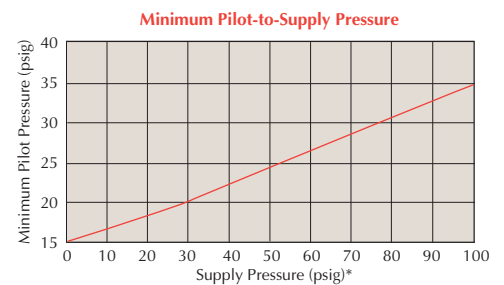
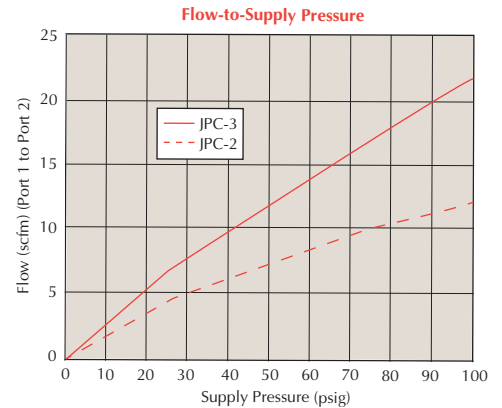
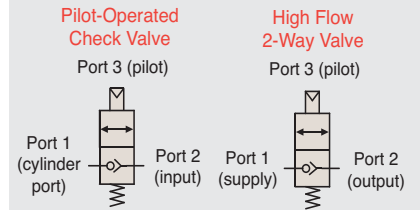

* Also available in corrosion-resistant materials. Add "CR-" to the beginning of the Part No.

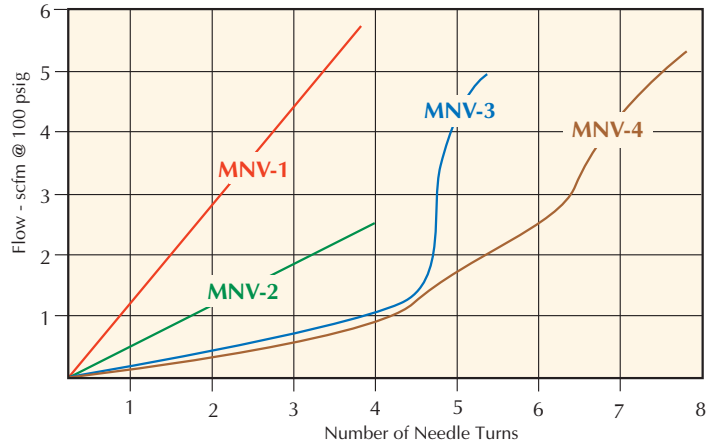
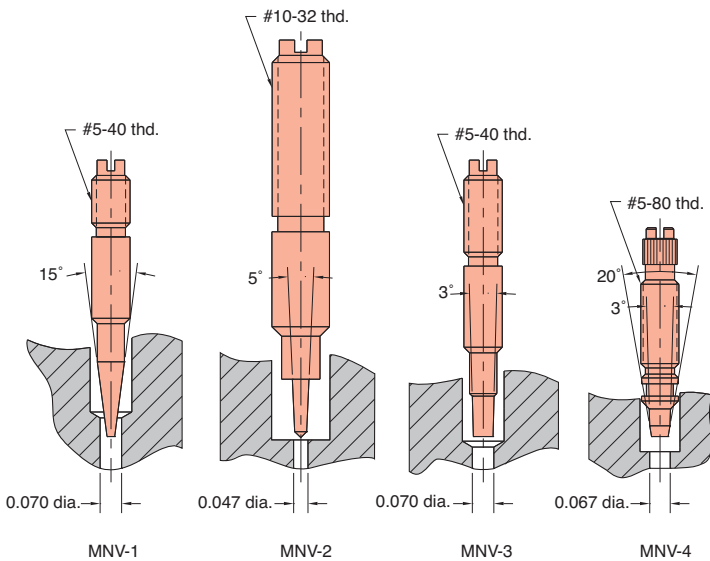

Adjustable control needle valves restrict flow in both directions. There are four models offered by Clippard, all with #10-32 ports, but with various needle configurations to provide coarse or fine flow adjustment. The diagram of needle shapes and the chart on this page show the difference between these models.

Medium: Air, Water or Oil

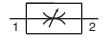

Materials: Brass body; stainless steel needle; Nitrile seal

Mounting: Direct, in-line or #15/32-32 thread nut and lockwashers furnished as illustrated

Adjustment: Knurled knob (clockwise adjustment provides less flow), or Screwdriver slot (clockwise adjustment provides less flow).



15° Needle Valves, #10-32



Input Pressure: 2,000 psig max.
Air Flow: 3 scfm @ 50 psig; 6 scfm @ 100 psig

15° Needle Valves, 1/8" NPT

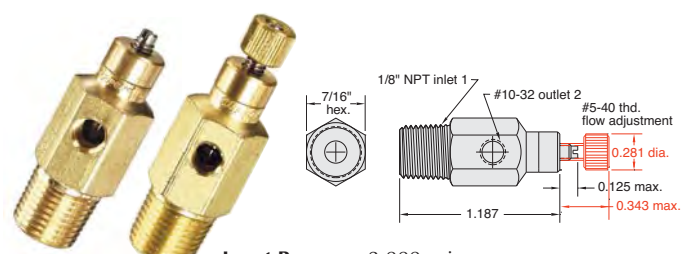

Input Pressure: 2,000 psig max.
Air Flow: 3 scfm @ 50 psig; 6 scfm @ 100 psig

Part No.	Description
MNV-1	Needle Valve, #10-32, Screwdriver Slot
MNV-1K	Needle Valve, #10-32, Knurled Knob

Part No.	Description
MNV-1P	Needle Valve, 1/8" NPT, Screwdriver Slot
MNV-1KP	Needle Valve, 1/8" NPT, Knurled Knob

5° Needle Valves, #10-32

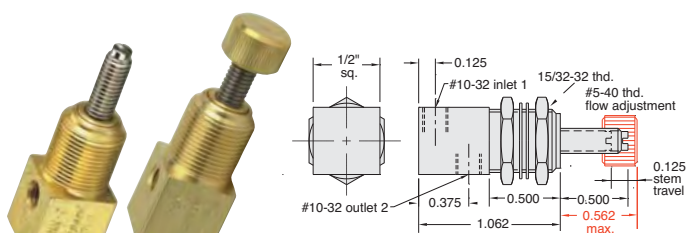

Input Pressure: 300 psig max.
Air Flow: 1 scfm @ 50 psig; 2.5 scfm @ 100 psig

3° Needle Valves, #10-32



Input Pressure: 2,000 psig max.
Air Flow: 2.5 scfm @ 50 psig; 5 scfm @ 100 psig

Part No.	Description
MNV-2	Needle Valve, #10-32, Screwdriver Slot
MNV-2K	Needle Valve, #10-32, Knurled Knob

Part No.	Description
MNV-3	Needle Valve, #10-32, Screwdriver Slot
MNV-3K	Needle Valve, #10-32, Knurled Knob

Metric line available. Visit www.clippard.com

3° Needle Valves, 1/8" NPT

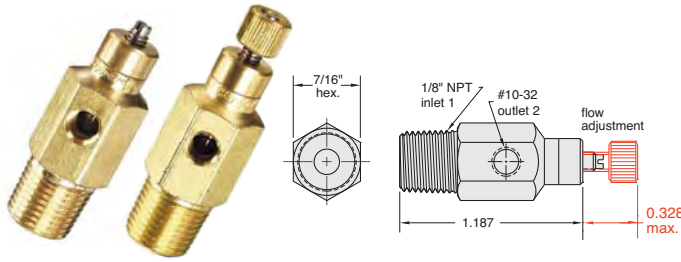

Input Pressure: 2,000 psig max.

Air Flow: 2.5 scfm @ 50 psig; 5 scfm @ 100 psig

Part No.	Description
MNV-3P	Needle Valve, #10-32, Screwdriver Slot
MNV-3KP	Needle Valve, #10-32, Knurled Knob



3° Needle Valves, #10-32

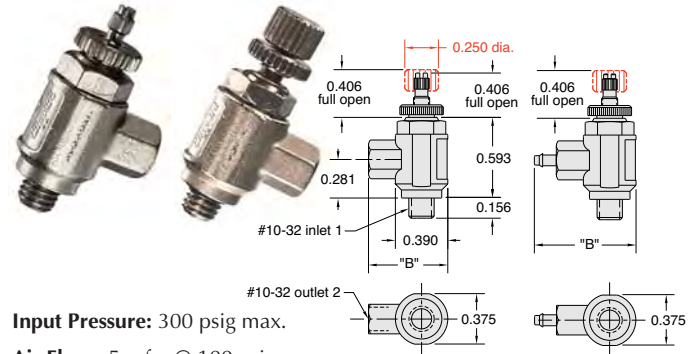

Input Pressure: 300 psig max.

Air Flow: 5 scfm @ 100 psig

Part No.	Side Port	"B"	Note: Knurled locking nut standard
MNV-4	#10-320.593	Screwdriver Slot
MNV-41	1/16 Barb	. . .0.750	
MNV-42	1/8 Barb	. . .0.906	Knurled Knob
MNV-4K	#10-320.593	
MNV-4K1	1/16 Barb	. . .0.750	
MNV-4K2	1/8 Barb	. . .0.906	

Speed Control Mufflers

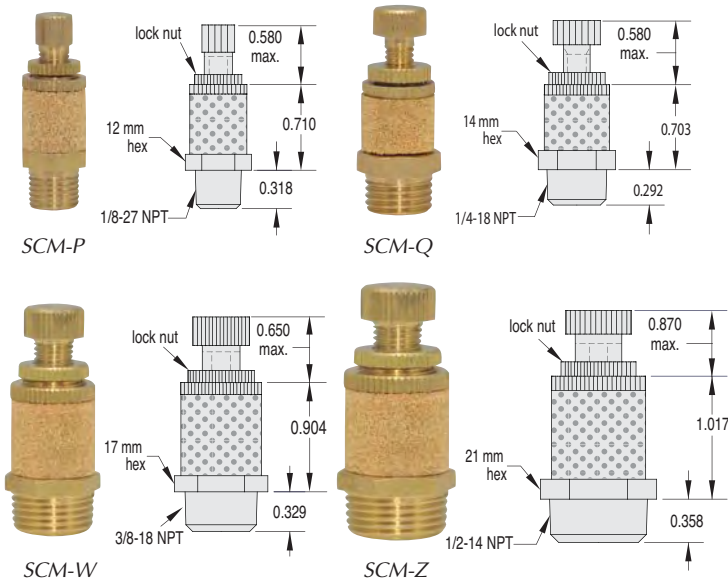

Knurled knob length based on minimum thread engagement.

Material: Solid brass body; sintered bronze muffler (40 micron)

Part No.	Description
SCM-P	Muffler, 1/8-27 NPT
SCM-Q	Muffler, 1/4-18 NPT
SCM-W	Muffler, 3/8-18 NPT
SCM-Z	Muffler, 1/2-14 NPT

NEW! 3° Cartridge Needle Valves

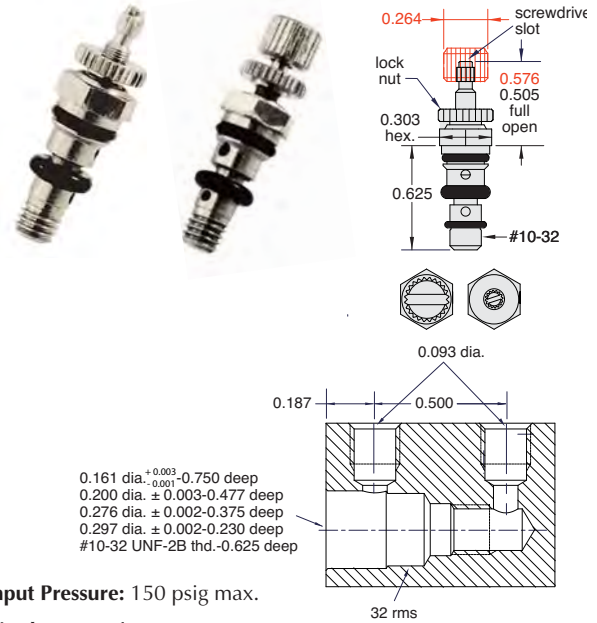

Input Pressure: 150 psig max.

Air Flow: 5 scfm @ 100 psig

Part No.	Description
MNV-4C	4-Way Needle Cartridge Valve, Screwdriver Slot
MNV-4CK	4-Way Needle Cartridge Valve, Knurled Knob

Needle Valves are used to control the rate of flow in a pneumatic system by controlling flow in both directions. Material enters the input port, travels through an adjustable orifice and out the output port. Available with multiple port sizes, flow rates, mounting options and adjustment styles.

Medium: Air, Water or Oil

Input Pressure: 300 psig max.

Air Flow: GNV-3: 11 scfm @ 100 psig
 GNV-4: 45 scfm @ 100 psig
 GNV-5: 60 scfm @ 100 psig

Materials: Electroless nickel plated brass body and needle, anodized aluminum housing

Mounting: Direct, in-line or cartridge style

Ports: Rotating input allows 360° positioning

Adjustment: Recessed slotted needle or knurled knob

Seals: Nitrile standard. FKM optional.

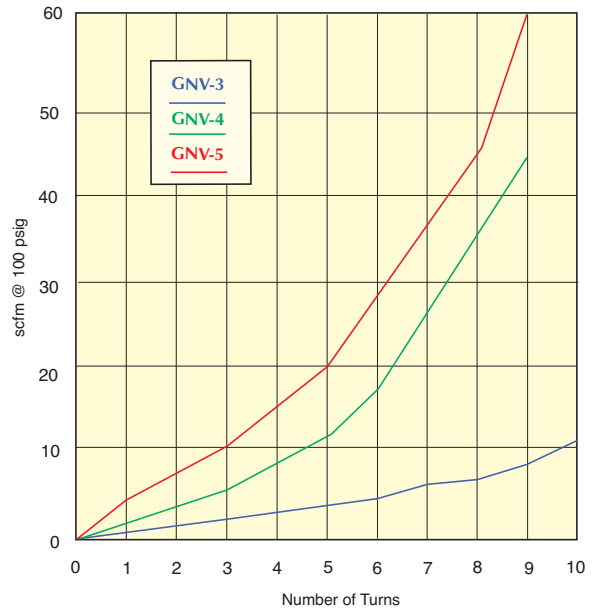
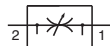

- Provide bidirectional flow control
- Rugged and compact design
- Multiple mounting options
- 360° rotating ports
- Ideal for use with Push-Quick fittings

Direct Mount Needle Valves, 1/8" NPT



(GNV-3R shown)

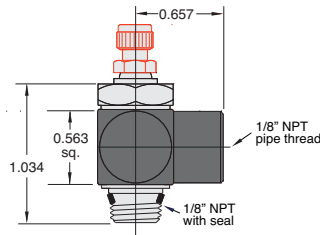

Part No.	Description
GNV-3R	Needle Valve, 1/8" NPT, Screwdriver Slot
GNV-3K	Needle Valve, 1/8" NPT, Knurled Knob

Direct Mount Needle Valves, 1/4" NPT



(GNV-4K shown)

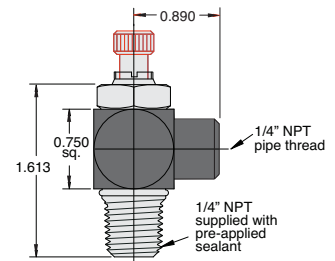

Part No.	Description
GNV-4R	Needle Valve, 1/4" NPT, Screwdriver Slot
GNV-4K	Needle Valve, 1/4" NPT, Knurled Knob

Direct Mount Needle Valves, 3/8" NPT



(GNV-5K shown)

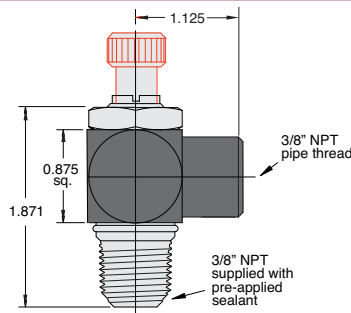

Part No.	Description
GNV-5R	Needle Valve, 3/8" NPT, Screwdriver Slot
GNV-5K	Needle Valve, 3/8" NPT, Knurled Knob

In-Line Mount Needle Valves, 1/8" NPT



(GNV-3RI shown)

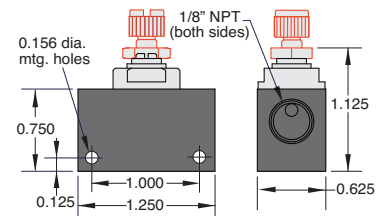

Part No.	Description
GNV-3RI	Needle Valve, 1/8" NPT, Screwdriver Slot
GNV-3KI	Needle Valve, 1/8" NPT, Knurled Knob

In-Line Mount Needle Valves, 1/4" NPT

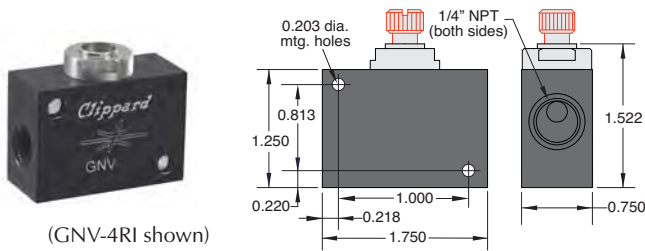

(GNV-4RI shown)

Part No.	Description
GNV-4RI	Needle Valve, 1/4" NPT, Screwdriver Slot
GNV-4KI	Needle Valve, 1/4" NPT, Knurled Knob

In-Line Mount Needle Valves, 3/8" NPT

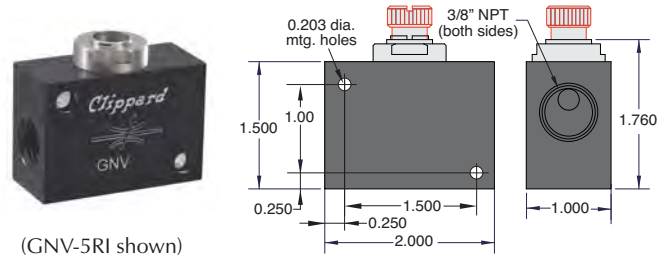

(GNV-5RI shown)

Part No.	Description
GNV-5RI	Needle Valve, 3/8" NPT, Screwdriver Slot
GNV-5KI	Needle Valve, 3/8" NPT, Knurled Knob

Cartridge Needle Valves

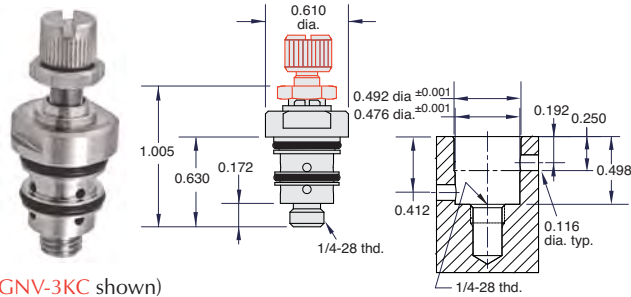

(GNV-3KC shown)

Part No.	Description
GNV-3RC	Cartridge Needle Valve, Screwdriver Slot
GNV-3KC	Cartridge Needle Valve, Knurled Knob

Cartridge Needle Valves

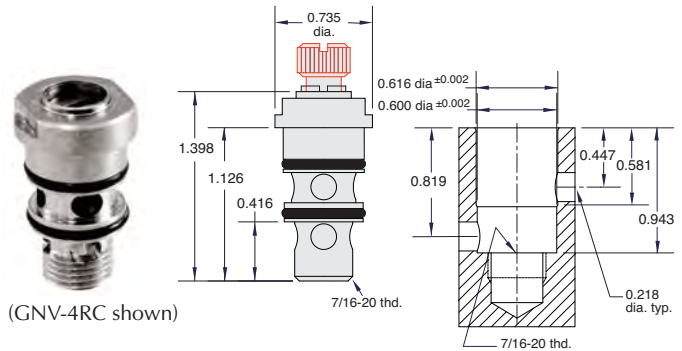

(GNV-4RC shown)

Part No.	Description
GNV-4RC	Cartridge Needle Valve, Screwdriver Slot
GNV-4KC	Cartridge Needle Valve, Knurled Knob

Cartridge Needle Valves

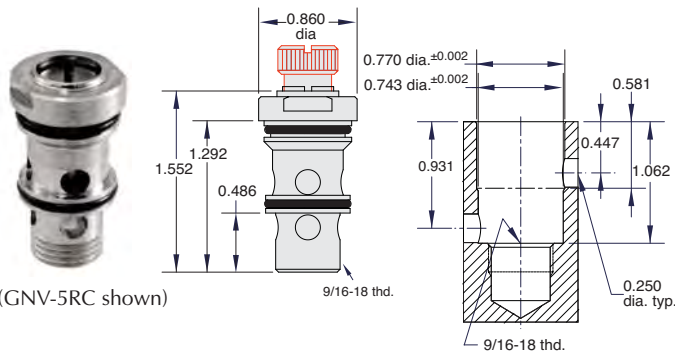

(GNV-5RC shown)

Part No.	Description
GNV-5RC	Cartridge Needle Valve, Screwdriver Slot
GNV-5KC	Cartridge Needle Valve, Knurled Knob



Clippard Push-Quick

Fittings provide a simple method to connect pneumatic components to each other and system piping, and accept both flexible hose and rigid tubing. Both fittings and tubing are available in many styles, sizes and colors.

Flow Controls Flow vs. Needle Turns

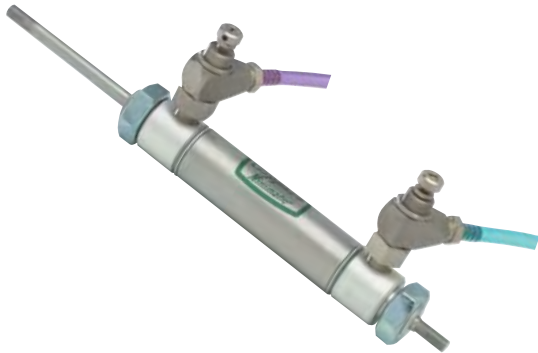

Clippard offers five models of adjustable flow controls with #10-32 through 3/8" NPT ports. They feature a combination needle and check valve that controls flow in one direction and allows free flow in the opposite direction.

They are an ideal valve for use with a cylinder, providing a slow extend stroke while allowing a fast retract stroke. The chart on this page illustrates the flow versus the number of needle adjustments turns for the MFC-2, MFC-3, BFC-3, JFC-2, JFC-3, JFC-4 and JFC-5.

Medium: Air, Water or Oil

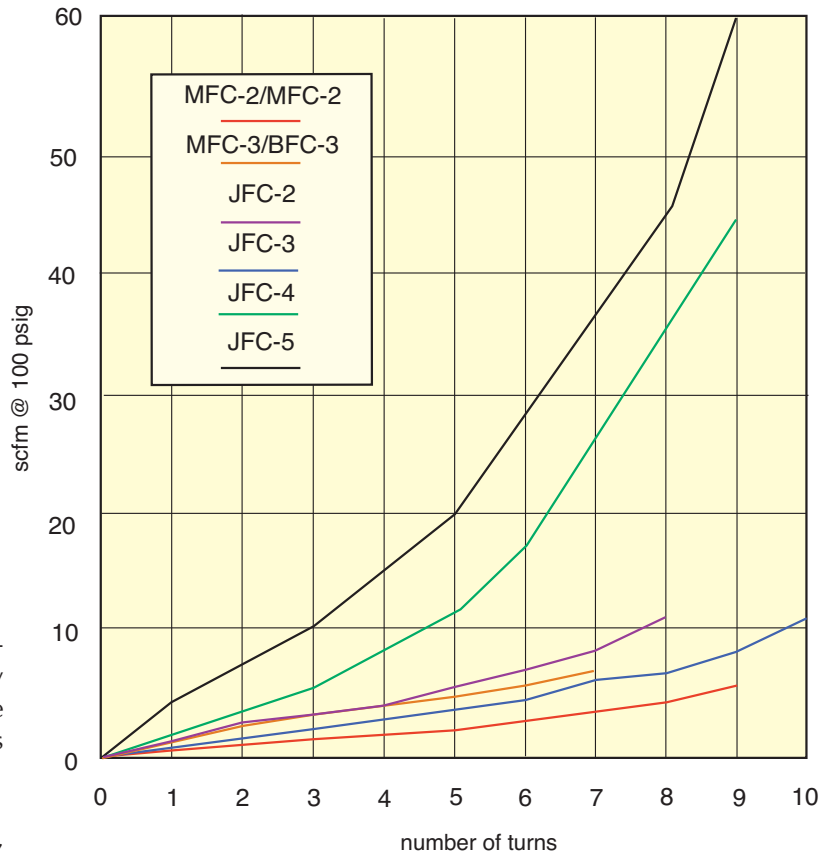

Adjustable Flow Control Valve

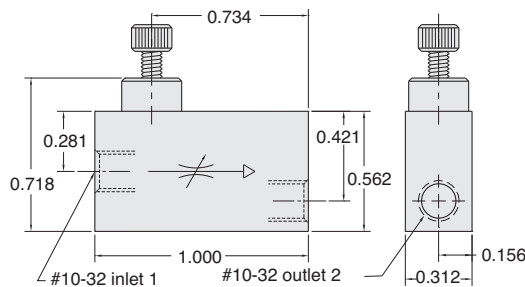

Materials: Brass body and stainless steel needle; Nitrile seals

Input Pressure: 300 psig max.

Air Flow: 4 scfm max. @ 50 psig; 7 scfm max. @ 100 psig

Pressure To Open: Cracks at approx. 2 psig

Mounting: In-line

Flow Direction: Arrow in valve body shows direction of controlled flow

Adjustment: Knurled knob on needle shaft



Part No.	Description
MFC-2	Adjustable Flow Control Valve, #10-32

Input Pressure: 150 psig max.

Mounting: Directly into #10-32 port

Ports: Rotating input port allows 360° positioning #10-32 port

Flow Direction: Arrow on valve body shows direction of controlled flow

Adjustment: Screwdriver slot; slotted knurled knob with lock nut on #5-80 (MFC) or #10-80 (JFC) threaded needle shaft for fine adjustment; or recessed slotted needle

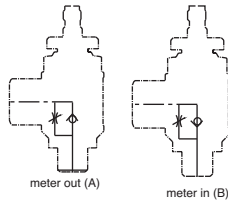

#10-32 Valves, Knurled Knob

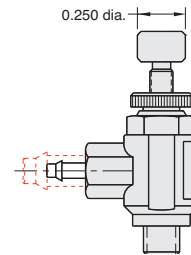

Part No.	Description
MFC-3AK	Meter Out Control Valve, #10-32 Female Side Port
MFC-3AK1	Meter Out Control Valve, 1/16" Barb Side Port
MFC-3AK2	Meter Out Control Valve, 1/8" Barb Side Port
MFC-3BK	Meter In Control Valve, #10-32 Female Side Port
MFC-3BK1	Meter In Control Valve, 1/16" Barb Side Port
MFC-3BK2	Meter In Control Valve, 1/8" Barb Side Port

#10-32 Valves, Screwdriver Slot

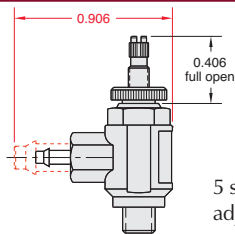

5 scfm @ 100 psig adjustable

Part No.	Description
MFC-3A	Meter Out Control Valve, #10-32 Female Side Port
MFC-3A1	Meter Out Control Valve, 1/16" Barb Side Port
MFC-3A2	Meter Out Control Valve, 1/8" Barb Side Port
MFC-3B	Meter In Control Valve, #10-32 Female Side Port
MFC-3B1	Meter In Control Valve, 1/16" Barb Side Port
MFC-3B2	Meter In Control Valve, 1/8" Barb Side Port

#10-32 Valves, Recessed Needle

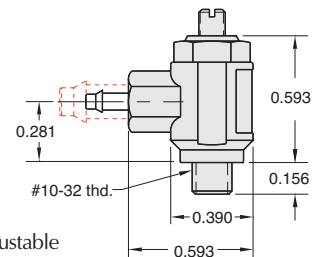

5 scfm @ 100 psig adjustable

Part No.	Description
MFC-3AR	Meter Out Control Valve, #10-32 Female Side Port
MFC-3AR1	Meter Out Control Valve, 1/16" Barb Side Port
MFC-3AR2	Meter Out Control Valve, 1/8" Barb Side Port
MFC-3BR	Meter In Control Valve, #10-32 Female Side Port
MFC-3BR1	Meter In Control Valve, 1/16" Barb Side Port
MFC-3BR2	Meter In Control Valve, 1/8" Barb Side Port

1/8" NPT Control Valves, Knurled Knob



11 scfm @ 100 psig adjustable

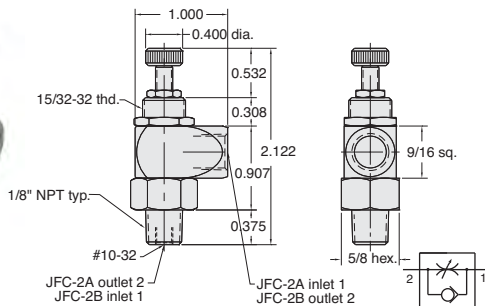

Part No.	Description
JFC-2A	Meter Out Control Valve, 1/8" NPT
JFC-2B	Meter In Control Valve, 1/8" NPT

1/8" NPT Valves, Knurled Knob

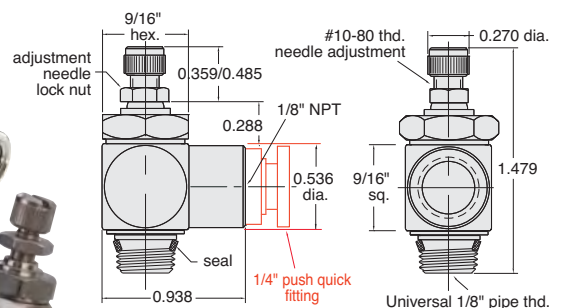

11 scfm @ 100 psig adjustable

Part No.	Description
JFC-3A	Meter Out Control Valve, 1/8" NPT
JFC-3B	Meter In Control Valve, 1/8" NPT
JFC-3AP08	Meter Out Control Valve, 1/4" Push-Quick Fitting
JFC-3BP08	Meter In Control Valve, 1/4" Push-Quick Fitting

1/8" NPT Valves, Recessed Needle



11 scfm @ 100 psig adjustable

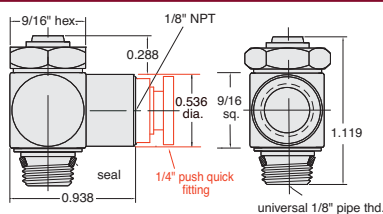

Part No.	Description
JFC-3AR	Meter Out Control Valve, 1/8" NPT
JFC-3BR	Meter In Control Valve, 1/8" NPT
JFC-3ARP08	Meter Out Control Valve, 1/4" Push-Quick Fitting
JFC-3BRP08	Meter In Control Valve, 1/4" Push-Quick Fitting



These combination needle and check valve flow controls are typically used to control air flow from air cylinders, thereby controlling the speed at which

Medium: Air, Water or Oil

Material: Electroless nickel plated brass needle and stem, anodized aluminum body, Nitrile seals

Input Pressure: 150 psig max.

Air Flow: JFC-4: 45 scfm @ 100 psig adjustable
JFC-5: 60 scfm @ 100 psig adjustable

Mounting: Directly into cylinder. Panel or in-line.



the piston strokes, either while extending or retracting, depending on their location in the circuit.

J-Series Flow Control Valves allow free flow in one direction. In the opposite direction the flow is metered by the needle valve.

Models listed in the chart have either a 1/4" NPT (JFC-4) or 3/8" NPT (JFC-5) male threaded outlets, recessed screwdriver slot (R) or knurled knob (K) flow adjustment needles and female NPT or push-to-connect tubing (Push-Quick) inlets. The P08 models features a 1/4" Push-Quick fitting, and the P12 versions have a 3/8" Push-Quick fitting.

Part #	"D"	"W"
JFC-4K & JFC-4R	0.710"	0.875"
JFC-4K-P08 & JFC-4R-P08	0.562"	1.062"
JFC-4K-P12 & JFC-4R-P12	0.710"	1.250"
JFC-5K & JFC-5R	0.827"	1.125"
JFC-5K-P12 & JFC-5R-P12	0.750"	1.375"

1/4" NPT Valves, Recessed Needle



(JFC-4R shown)

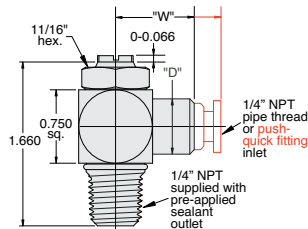

Part No.	Description
JFC-4R	Meter Out Control Valve, 1/4" NPT
JFC-4R-P08	Meter Out Control Valve, 1/4" Push-Quick Fitting
JFC-4R-P12	Meter Out Control Valve, 3/8" Push-Quick Fitting

1/4" NPT Valves, Adjusting Knob



(JFC-4K shown)

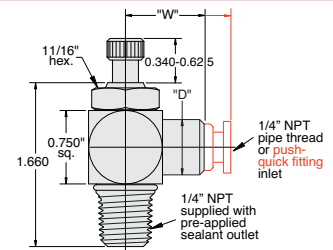

Part No.	Description
JFC-4K	Meter Out Control Valve, 1/4" NPT
JFC-4K-P08	Meter Out Control Valve, 1/4" Push-Quick Fitting
JFC-4K-P12	Meter Out Control Valve, 3/8" Push-Quick Fitting

3/8" NPT Valves, Adjusting Knob



(JFC-5K-P12 shown)

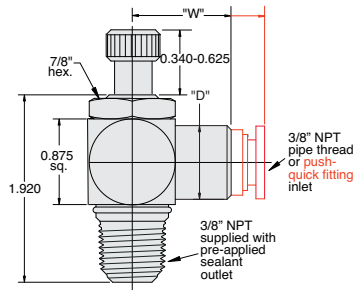

Part No.	Description
JFC-5K	Meter Out Control Valve, 3/8" NPT
JFC-5K-P12	Meter Out Control Valve, 3/8" Push-Quick Fitting

3/8" NPT Valves, Recessed Needle



(JFC-5R-P12 shown)

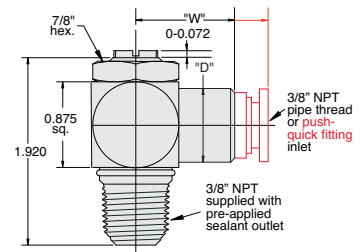

Part No.	Description
JFC-5R	Meter Out Control Valve, 3/8" NPT
JFC-5R-P12	Meter Out Control Valve, 3/8" Push-Quick Fitting



PQ-FV In-Line Flow Controls can be easily added to existing circuitry and are lightweight and compact in size. Since it is a tube-to-tube connection, in-line flow controls may be installed as a meter-in or meter-out device.

The PQ-C Elbow Controls are ideal for low cost and lightweight applications when mounting directly to an NPT port on a cylinder or valve is required.

In the meter-out versions, intake air flows freely through the flow control; exhaust air is metered out through an adjustment screw. With the meter-in series, air is metered in through an adjustment screw; exhaust air flows freely. Control is varied through a finely threaded adjustment screw. A locking nut is provided so it can be secured in its final setting.

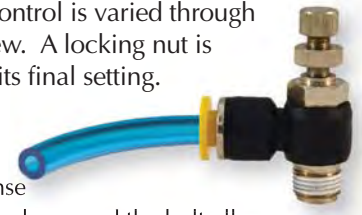

Medium: Air

Pressure Range: 0 to 150 psig

Vacuum: 0 to 29.5" Hg

Ports: #10-32, 1/8" NPT, 1/4" NPT, 3/8" NPT, 1/2" NPT

Adjustment: Knurled knob

Material: Nickel plated brass, plastic resin, stainless steel gripper ring, Nitrile seals

- Small, compact size
- Design flexibility and fast response
- Complete rotation of the valve body around the bolt allows for optimum positioning of tubing
- Special adjustment needle design allows large adjustment ranges with high precision
- Ideal for use with polyurethane, nylon, polyethylene and polypropylene tubing (see www.clippard.com)

PQ-CV & PQ-CI

PQ-FV

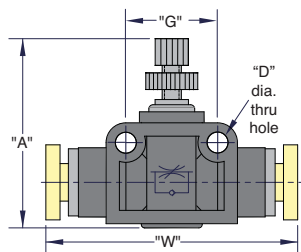
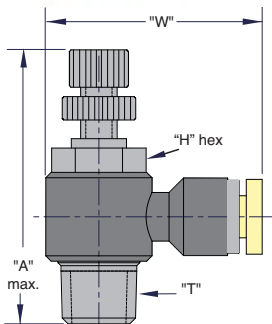

Right Angle Meter-Out Controls

Part No.	Tubing Size	Thread "T"	"H" Hex.	"A" Max.	"W"
PQ-CV04N	1/8"	#10-32	5/16"	1.230	0.990
PQ-CV04P	1/8"	1/8" NPT	7/16"	1.630	1.165
PQ-CV05N	5/32"	#10-32	5/16"	1.210	0.990
PQ-CV05P	5/32"	1/8" NPT	7/16"	1.570	1.130
PQ-CV08N	1/4"	#10-32	5/16"	1.240	1.090
PQ-CV08P	1/4"	1/8" NPT	7/16"	1.615	1.215
PQ-CV08Q	1/4"	1/4" NPT	9/16"	1.900	1.360
PQ-CV12Q	3/8"	1/4" NPT	9/16"	1.950	1.610
PQ-CV12W	3/8"	3/8" NPT	3/4"	2.395	1.690
PQ-CV16Q	1/2"	3/8" NPT	3/4"	2.270	1.745

Right Angle Meter-In Controls

Part No.	Tubing Size	Thread "T"	"H" Hex.	"A" Max.	"W"
PQ-CI04N	1/8"	#10-32	5/16"	1.230	0.990
PQ-CI04P	1/8"	1/8" NPT	7/16"	1.630	1.165
PQ-CI05N	5/32"	#10-32	5/16"	1.210	0.990
PQ-CI05P	5/32"	1/8" NPT	7/16"	1.570	1.130
PQ-CI08N	1/4"	#10-32	5/16"	1.240	1.090
PQ-CI08P	1/4"	1/8" NPT	7/16"	1.615	1.215
PQ-CI08Q	1/4"	1/4" NPT	9/16"	1.900	1.360
PQ-CI12Q	3/8"	1/4" NPT	9/16"	1.950	1.610
PQ-CI12W	3/8"	3/8" NPT	3/4"	2.395	1.690
PQ-CI16W	1/2"	3/8" NPT	3/4"	2.270	1.745

In-Line Controls

Part No.	Tubing Size	"D" Dia.	"G"	"A"	"W"
PQ-FV04	1/8"	0.125	0.550	1.087	1.570
PQ-FV05	5/32"	0.125	0.550	1.250	1.570
PQ-FV06M	6 mm	0.170	0.787	1.683	1.952
PQ-FV08	1/4"	0.170	0.787	1.739	2.010
PQ-FV08M	8 mm	0.170	0.860	1.744	2.173
PQ-FV12	3/8"	0.170	1.023	2.105	2.520
PQ-FV16	1/2"	0.170	1.260	2.156	2.881

Block Flow Controls

- [BFC-2A](#)
- [BFC-2B](#)
- [BFC-2AK](#)
- [BFC-2BK](#)
- [BFC-4A](#)
- [BFC-4B](#)
- [BFC-4AK](#)
- [BFC-4BK](#)
- [BFC-6A](#)
- [BFC-6B](#)
- [BFC-6AK](#)
- [BFC-6BK](#)
- [BFC-8A](#)
- [BFC-8B](#)
- [BFC-8AK](#)
- [BFC-8BK](#)

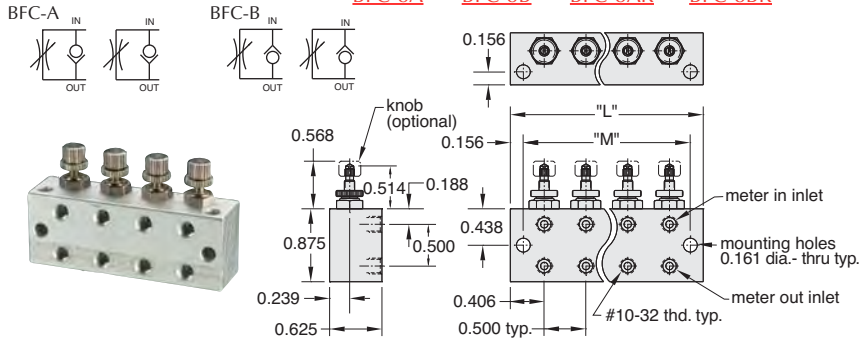

Block Flow Controls

- [BFC-2C](#)
- [BFC-2CK](#)

Two valves common meter in and meter out.

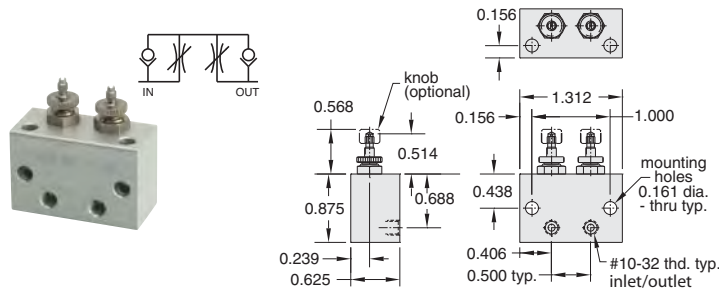

Block Needle Valves

- [BNV-2N](#)
- [BNV-4N](#)
- [BNV-6N](#)
- [BNV-8N](#)
- [BNV-2NK](#)
- [BNV-4NK](#)
- [BNV-6NK](#)
- [BNV-8NK](#)

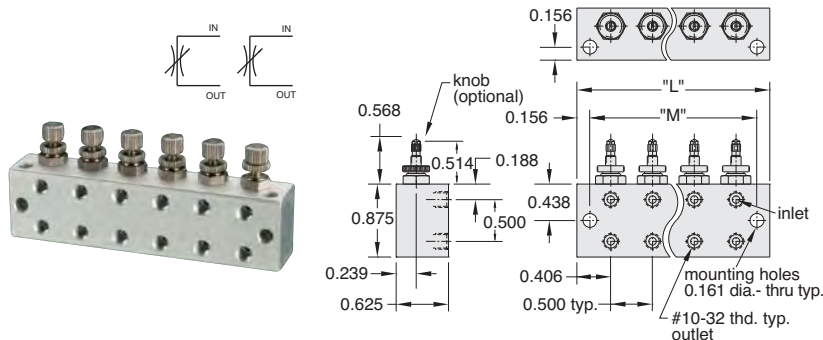

Block Needle Manifolds

- [BNM-2N](#)
- [BNM-4N](#)
- [BNM-6N](#)
- [BNM-8N](#)
- [BNM-2NK](#)
- [BNM-4NK](#)
- [BNM-6NK](#)
- [BNM-8NK](#)

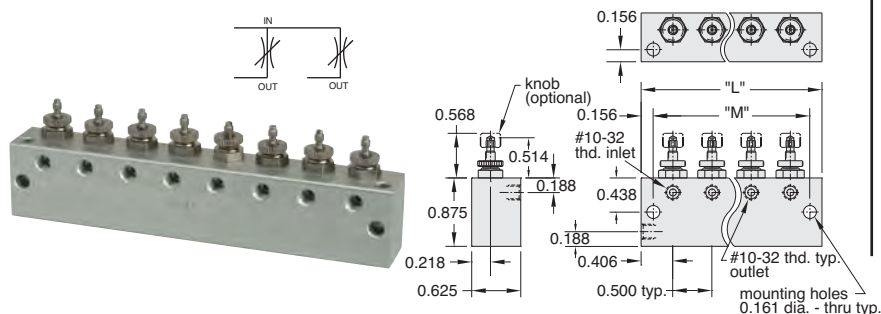

Precision flow controls and needle valves available in blocks for rigid mounting.

Specification same as MFC-3

Clippard's block flow control and needle valves have a variety of features that offer extra versatility for unique applications. These precision made valves offer high performance, low cost, reliability and ease of installation. Each valve is independent of the other (except the BFC-2C), sharing only a common body. This allows separate pressures and/or gases to be used while simplifying mounting. Each needle adjustment is smooth, exact, and includes a locking ring to prevent tampering. The valve body is machined and anodized aluminum; the compound angle needle stems are machined from 303 stainless steel; the valve sleeve is electroless nickel plated brass; and the seals are Nitrile rubber. Block flow controls and needle valves are ideal for controlling double acting cylinders.

FC - Flow Control
 NV - Needle Valve
 NM - Needle Manifold



Block

Number of stations

- 2 - 2 Stations
- 4 - 4 Stations
- 6 - 6 Stations
- 8 - 8 Stations

- A - Meter Out Flow
- B - Meter In Flow
- C - 2 Valves Common Meter In and Meter Out
- N - Needle Valve

Adjustment type

- Blank - Screwdriver Slot
- K - Adjustment Knob

Number of Stations	"X"	"L"	"M"
2		1.312"	1.000"
4		2.312"	2.000"
6		3.312"	3.000"
8		4.312"	4.000"

Shuttle Valves

There are three models of shuttle valves offered by Clippard. These valves feature a shuttle that allows flow from one inlet to the outlet while blocking the other inlet. They may be mounted directly to valves and cylinders or in-line using the hose bars on the MSV models.

Poppet type shuttle (double check) valve. Brass body, and poppet, Nitrile seal



Medium: Air, Water or Oil

Input Pressure: 250 psig max.

Air Flow: 5.0 scfm @ 50 psig; 9.5 scfm @ 100 psig

Mounting: Direct or in-line

Operation: Flow from "A" to "C" or "B" to "C"

Pressure to Shift: 1/2 psig approx.

Exhaust: Through port where pressure was last applied



Note: Shuttle valves should not be used as a pressure selector

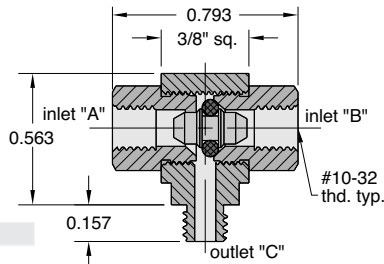

Part No.
MSV-1

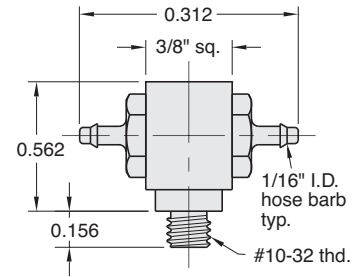

Part No.
MSV-1M22

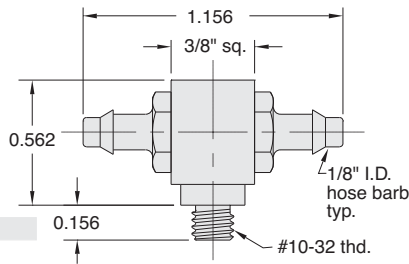

Part No.
MSV-1M44



Part No.
MSV-1FFF

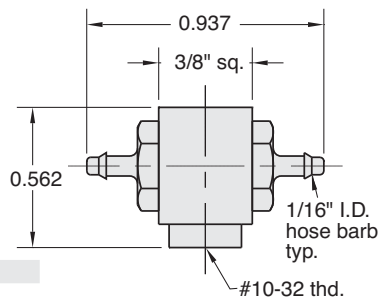

Part No.
MSV-1F22

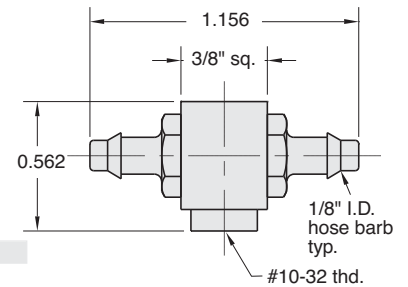

Part No.
MSV-1F44

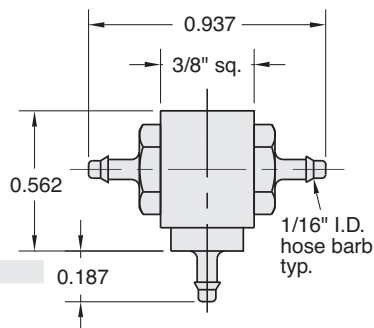

Part No.
MSV-1222

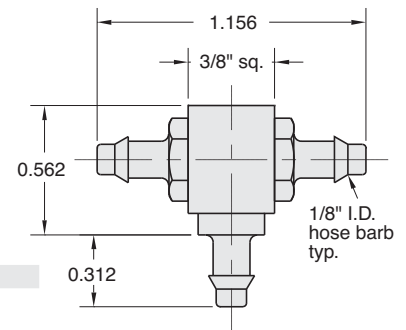

Part No.
MSV-1444

Poppet Type Shuttle Valves



Brass body, Delrin Poppet,
Nitrile seal

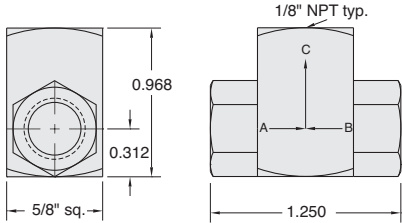

Medium: Air, Water or Oil

Input Pressure: 300 psig - air; 1,000 psig - hydraulic

Air Flow: 14 scfm @ 50 psig; 26 scfm @ 100 psig

Mounting: Direct or in-line

Operation: Flow from "A" to "C" or "B" to "C"

Pressure to Shift: 1/2 psig approx.

Note: Shuttle valves should not be used as a pressure selector

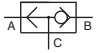

Part No. Description

MJSV-1 Poppet Shuttle Valve, 1/8" NPT

J-Series Shuttle Valves

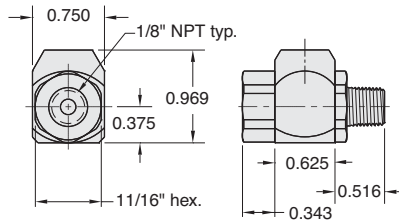

Part No.
JSV-2FPF

Poppet type shuttle
(double check) valve.
Brass body, stainless
steel shuttle, Nitrile
seal

Medium: Air, Water or Oil

Input Pressure: 300 psig max.

Air Flow: 30 scfm @ 50 psig
50 scfm @ 100 psig

Mounting: Direct or in-line

Pressure to Shift: 1 psig approx.

Note: Shuttle valves should not be used as a pressure selector

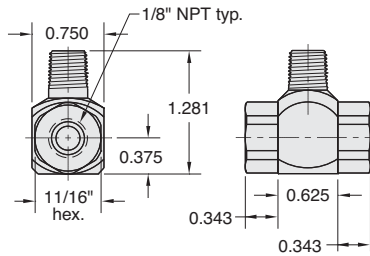

Part No.
JSV-2PFF

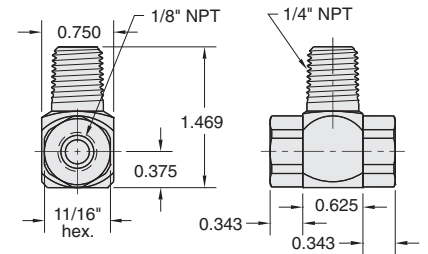

Part No.
JSV-2WFF

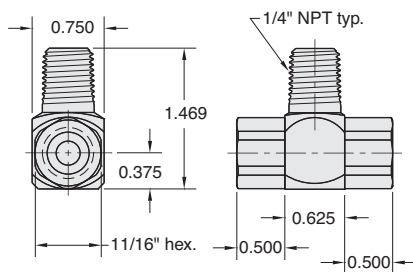

Part No.
JSV-2WYY

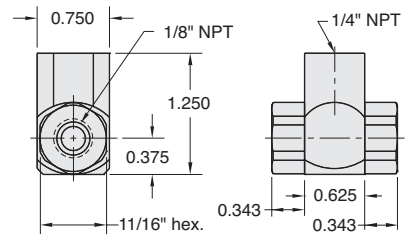

Part No.
JSV-2YFF

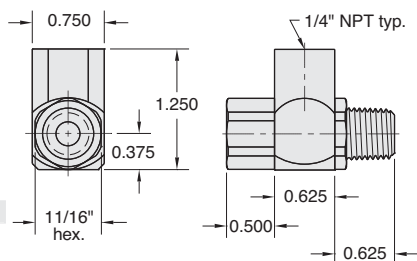

Part No.
JSV-2YYY

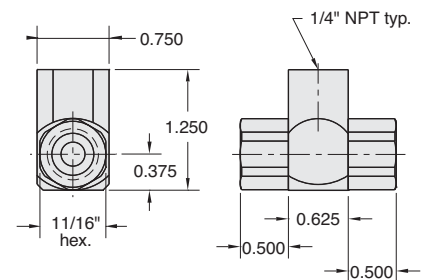

Part No.
JSV-2YYY

Quick Exhaust Valve Application

In a typical application the exhaust valve is installed in the inlet of a spring return or double acting pneumatic cylinder.

Supply air from a control valve is directed into the inlet port of the exhaust valve. The Nitrile poppet seals the exhaust port and allows air to flow from the outlet port of the valve into the cylinder.

The pressurized air pushes against the piston and extends the rod, compressing the spring, until full rod extension is achieved.

When the control valve exhausts air from the exhaust valve inlet port, the Nitrile poppet shifts to seal the inlet port and open the exhaust port to the cylinder. The pressurized air is allowed to exhaust directly through the exhaust valve to atmosphere.

Normally the air must travel back through the long air line to the control valve to exhaust. By mounting the exhaust valve directly on the cylinder, the piston retracts quickly since the distance to atmosphere is very short and unrestricted.

Cylinder Extends

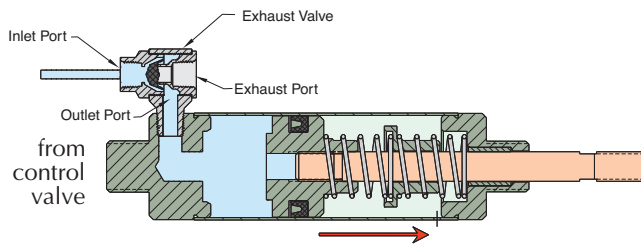

Cylinder Retracts - Fast!

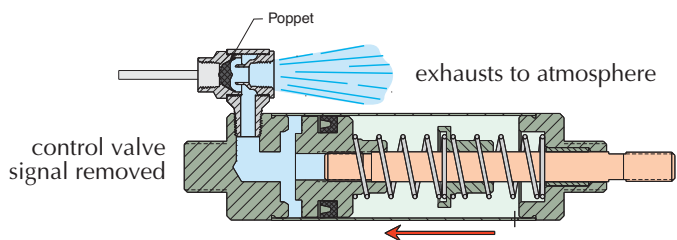

Poppet Quick Exhaust Valve

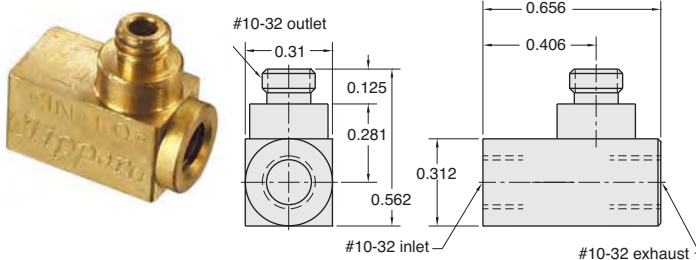

Part No.	Description
MEV-2	Poppet Type Quick Exhaust Valve, #10-32

Medium: Air

Material: Brass body, Nitrile poppet

Working Range: 15 to 150 psig

Air Flow: 5 scfm @ 50 psig; 9 scfm @ 100 psig (exhaust rate);

Mounting: Direct to cylinder

Pressure to Shift: @ 50 psig - opens after approx. 5 psig drop; @ 3.5 bar - opens after approx. 0.350 bar drop

Note: Not for use with cylinders larger than 7/8" dia.; moderate strokes up to 10"

Packaging Solutions

A leader in miniature pneumatics, Clippard provides the packaging industry a variety of products and solutions. We understand the needs of this industry, and are prepared to serve you with our expanding product lines and expertise in applications.

- Conveying applications
- Case erectors
- Process solutions
- Bottle/container filling
- Palletizing
- Controls for a variety of applications



J-Series Exhaust Valves

Clippard's J-Series Exhaust Valve offers a variety of design features and provides fast response times and high flow with 1/8" and 1/4" NPT ports. This compact poppet type valve is constructed of brass and is 100% tested to assure the highest quality. The JEV's primary function is to increase cylinder speed. However, it also enables the use of smaller directional valves, longer control lines and can be used as a shuttle valve. 32 versions available.

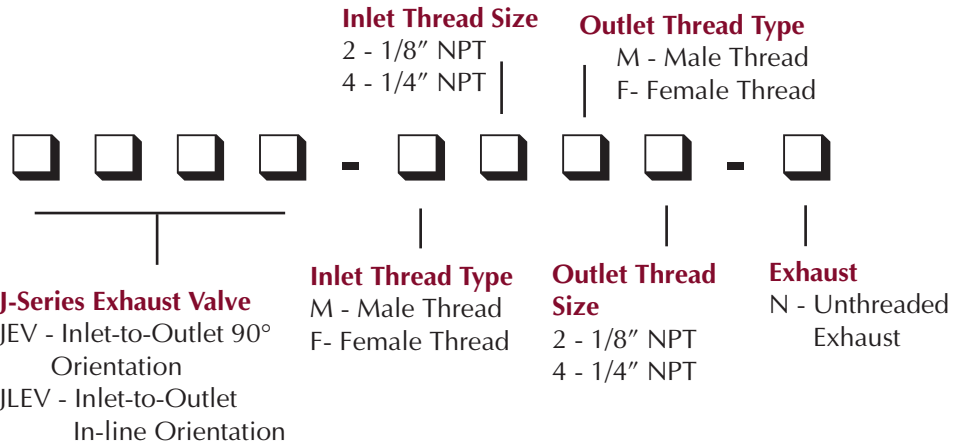

Part No. JEV-F2F2

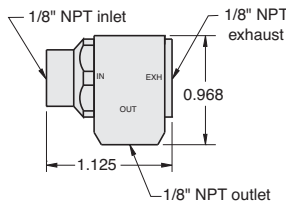

Part No. JEV-F2M4

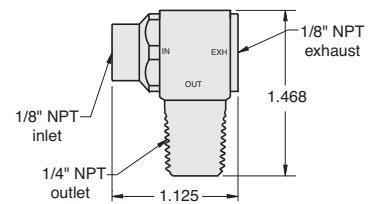

Part No. JEV-F2M2

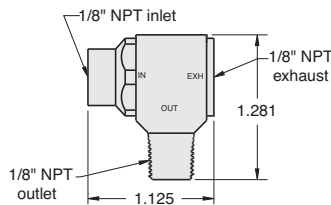

Part No. JLEV-F2M2-N

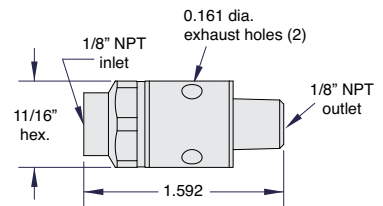

Part No. JEV-F4M4

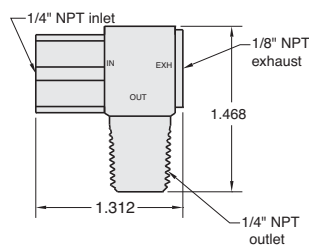

Part No. JLEV-F4M4-N

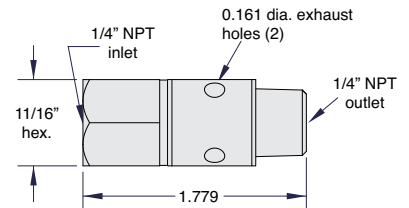

Part No. JEV-F4F4

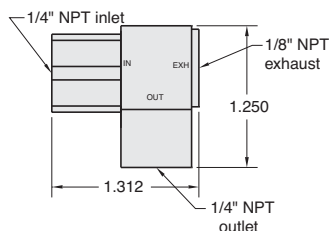

Features

- Enables use of smaller control valves
- 15 to 150 psig maximum
- Male outlet offers direct connection to cylinder
- 36 scfm @ 50 psig and 58 scfm @ 100 psig
- Low shift ratio
- 7 standard configurations
- Custom configurations also available
- Brass construction with molded Nitrile seal



Miniature Pulse Valves

A Normally-Open 3-way valve that closes shortly after being pressurized and remains closed until supply pressure is exhausted and repressurized. Widely used in control circuits.



Medium: Air

Input Pressure: 40 to 150 psig max.

Mounting: 1/8" NPT thread; nut furnished

Volume Chamber: #10-32

Operation: Converts a continuous supply of inlet air into a pulse of approximately 100 milliseconds

Response: 300 cycles per minute; time delay may be increased by adding standard Clippard volume chambers not to exceed 3 cu. in.

Construction: Body - ENP brass, Seals - Nitrile rubber, Spring - stainless steel, Poppet - Delrin®

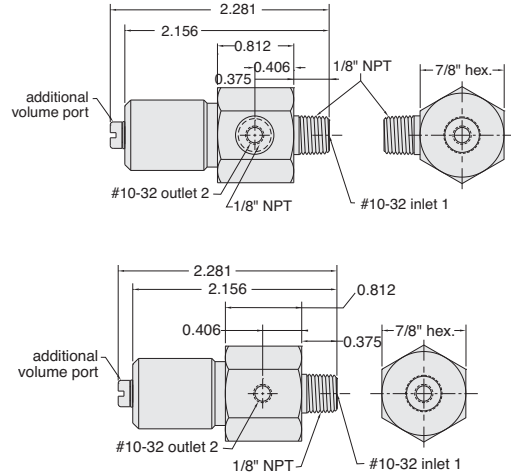
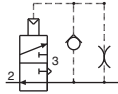

Part No.	Description
PV-1	Pulse Valve, #10-32
PV-1P	Pulse Valve, 1/8" NPT

In-Line Volume Chamber

Used for providing a time delay in pneumatic circuits

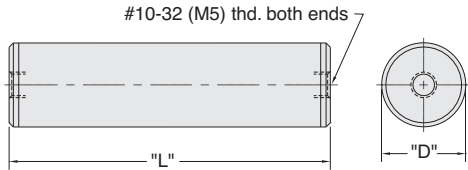

The time delay of the PV-1, PV-1P and R-711 may be increased by adding standard Clippard volume chambers. The charts show total TIME versus VOLUME for these combinations.

Volume CU. IN.	Volume Chamber
0.1	MAT-1
0.25	MAT-25
0.50	MAT-50
1.0	MAT-1.0
1.2	R-821
2.0	MAT-2.0
2.4	R-821 (2)
3.6	R-821 (3)
4.0	MAT-4.0

Suffix	Bore	"L"	"D"	Cu.In
0.1	3/8"	1.265"	0.437"	0.1
0.25	3/8"	2.640"	0.437"	0.25
0.5	9/16"	2.390"	0.625"	0.5
1.0	9/16"	4.390"	0.625"	1.0
2.0	15/16"	3.328"	1"	2.0
4.0	15/16"	6.234"	1"	4.0

Volume	Time in Seconds	
	PV-1	R-711
0	0.042	0.117
0.1	0.074	0.180
0.25	0.124	0.245
0.5	0.210	0.350
1.0	0.390	0.450
1.2	0.580	0.700
2.0	0.760	1.000
2.4	0.950	1.300
3.6	1.200	1.900
4.0	1.500	N.R.

Medium: Air only

Material: Brass

Input Pressure: 150 psig

Mounting: Direct or in-line; Mounting clamp with MAT-20 and MAT-4.0

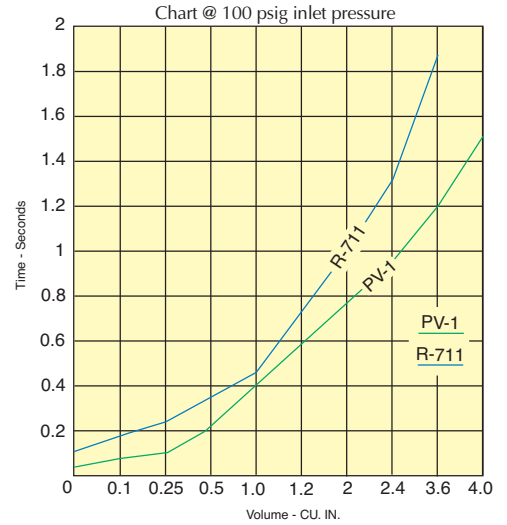

Part No.	Description
MAT-(size)	In-Line Volume Chamber, #10-32

Specify Size per Chart

R-821 volume charts are shown in the Modular Section of this catalog.

Piloted Actuated Water Drawback Valves

When this Normally-Closed valve closes a spring biased internal piston draws back a small volume on outlet side (approx. 6-7" in 1/8" I.D. tube) thus preventing overflow or dribbles. Ideal for use in quenching or water spray applications.

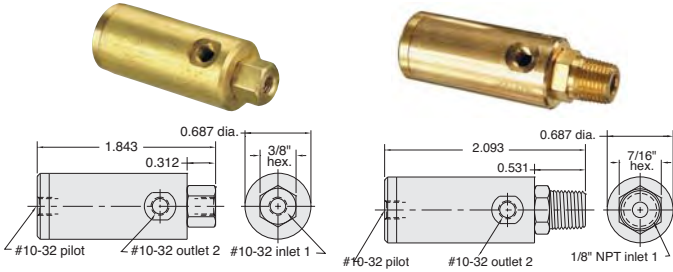

- Medium:** Water or Other Light Liquids
- Input Pressure:** 100 psig max.
- Pilot Pressure:** 25 psig min.
- Flow:** 74 cu. in. H₂O per min. @ 80 psig
- Drawback:** 0.07 cu. in. (1.2 ml)
- Mounting:** Mounts in-line

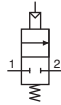

Part No.	Description
WDV-2	Poppet Valve with Air Pilot, #10-32
WDV-2P	Poppet Valve with Air Pilot, 1/8" NPT

Normally-Closed 2-Way Pilot Sensor

For use with pressure piloted control circuits, can repeatedly detect a position within 0.005" properly mounted. In jigs or fixtures it will signal correct position and start-ok to control circuit.

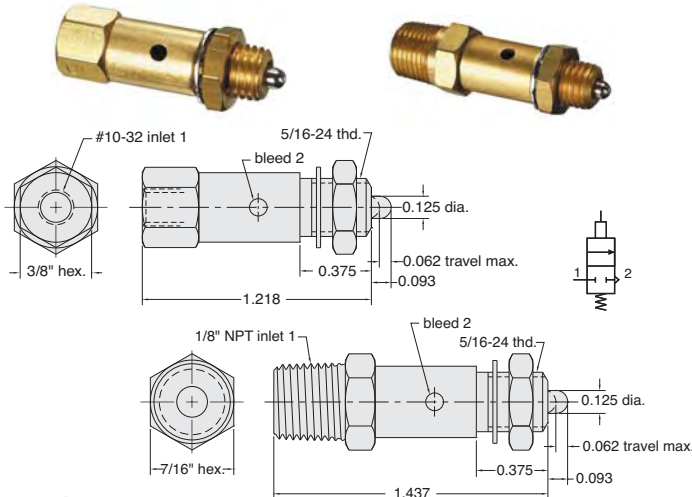

- Medium:** Air
- Stem Travel:** 1/16" max. (will open and close in as little as 0.005")
- Input Pressure:** 300 psig max. **Force For Full Stem Travel:** 7 oz. nominal
- Air Flow:** 3 scfm @ 50 psig; 6 scfm @ 100 psig
- Mounting:** #15/16-24 thread. Nut and lockwashers furnished

Part No.	Description
MPS-2	Poppet Valve with Pilot Sensor, #10-32
MPS-2P	Poppet Valve with Pilot Sensor, 1/8" NPT

2-Way N-C Whisker Valve

For use with bleed pressure piloted control circuits. Coil spring stainless steel whisker is easily replaceable and can be formed to different shapes.

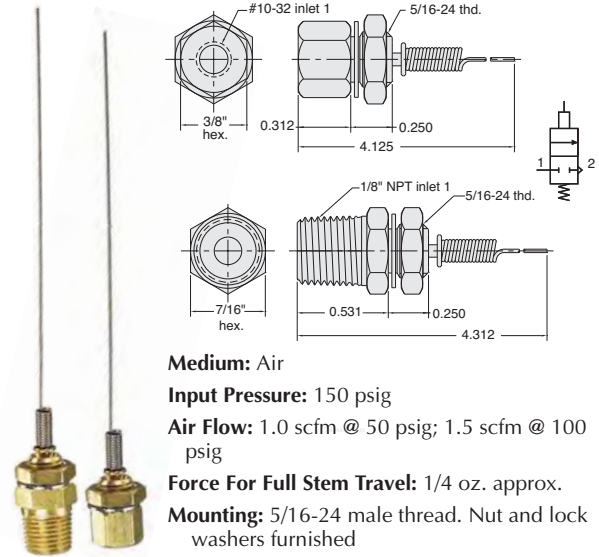

- Medium:** Air
- Input Pressure:** 150 psig
- Air Flow:** 1.0 scfm @ 50 psig; 1.5 scfm @ 100 psig
- Force For Full Stem Travel:** 1/4 oz. approx.
- Mounting:** 5/16-24 male thread. Nut and lock washers furnished
- Bleed:** To atmosphere around whisker stem

Whisker: Stainless steel, approx. 3" length.
Replacement Part No. 12375



Part No.	Description
MWV-1	Normally-Closed Whisker Valve, #10-32
MWV-1P	Normally-Closed Whisker Valve, 1/8" NPT

In-Line Fixed Orifice Air Chokes



Each choke is calibrated for precise flow

- Medium:** Air
- Material:** Brass
- Working Range:** 0 to 300 psig max.

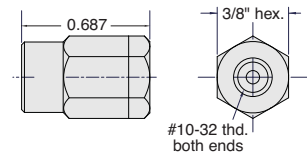

Part No.	Description
MAC-A	Air Choke, 0.0135" Hole, Yellow Disk
MAC-B	Air Choke, 0.010" Hole, Green Disk
MAC-C	Air Choke, 0.0075" Hole, Blue Disk
MAC-D	Air Choke, 0.006" Hole, Red Disk

- Materials:** Brass body, Nitrile seals, stainless steel stem and spring
- Temperature Range:** 32 to 230°F
- Options:** Consult the factory concerning the price and availability of the following standard options:

- ENP** - Electroless Nickel Plating
- E** - EPDM Seals
- V** - FKM Seals

Multi-Pin Air Indicator

Plunger type (when extended 7-pin color display signals "on")

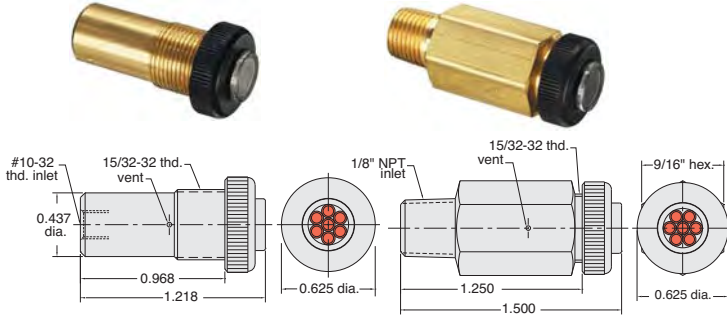

Medium: Air Only

Input Pressure: 150 psig max.

Minimum Actuation Pressure: 15 psig approx.

Response: Approx. 10 milliseconds @ 50 psig

Filtration: 40 micron recommended

Mounting: IND-3: Panel mount in hole. #15/32-32 nut and lockwasher provided; IND-3P: Direct mount into 1/8" NPT hole

Maximum Panel Thickness: 3/16"



Part No.	Description
IND-3-(color)	Multi-Pin Air Indicator, #10-32
IND-3P-(color)	Multi-Pin Air Indicator, 1/8" NPT

GN-Green, WH-White, RD-Red, YL-Yellow

Single Pin Air Indicator

Plunger type (when extended white pin display signals "on")

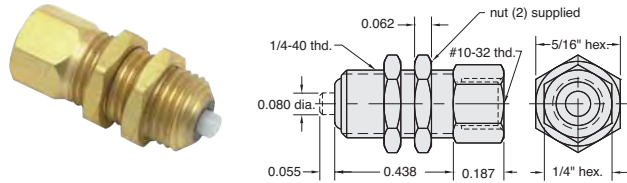

Part No.	Description
IND-1-WH	Single Pin Air Indicator

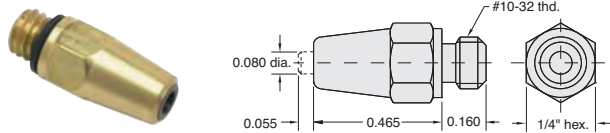

Part No.	Description
IND-1M-WH	Single Pin Air Indicator

Medium: Air Only

Input Pressure: 150 psig max.

Minimum Actuation Pressure: 12 psig approx.

Response: Approx. 10 milliseconds @ 50 psig

Filtration: 40 micron recommended

Mounting: IND-1-WH: Panel mount 1/4 dia. hole. 1/4-40 thd. nuts provided. IND-1M-WH: Direct mount into #10-32 port

Maximum Panel Thickness: 3/16"



Vacuum Gauge

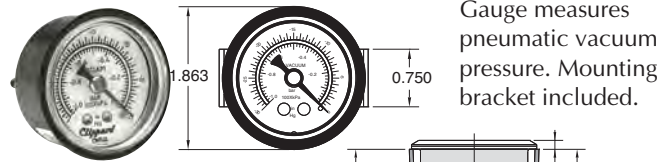

Gauge measures pneumatic vacuum pressure. Mounting bracket included.

Range: Scale reading from 0 to 30" Hg. and 0 to -1 bar

Construction: Nickel-plated steel case. Plastic face. Dial shows two ranges; Hg in black. Bars in red. Built-in pressure snubber.

Ports: Connection located at rear is double threaded O.D. - male thread 1/8" NPT, I.D. - tapped for #10-32 fitting

Mounting: Stud mount using 1/8" NPT center stud or panel mount using the zinc plated steel bracket supplied.

Part No.	Description
VG-30	Vacuum Gauge

Pressure Gauges

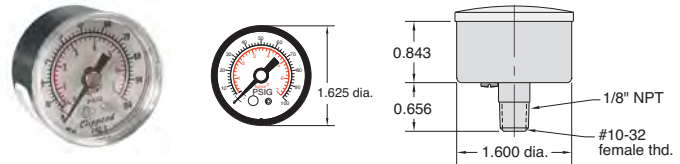

Gauge measures pneumatic system pressure. Stud mounted.

Range: Scale reading from 0 to 100 psig and 0 to 6.9 bar

Construction: Steel case. Plastic face. Dial shows two ranges; psig in black. Bars in red. Built-in pressure snubber.

Ports: Connection located at rear is double threaded O.D. - male thread 1/8" NPT; I.D. - tapped for #10-32 fitting

Mounting: Direct with 1/8" NPT

Part No.	Description
PG-101-BK	Pressure Gauge, Black Case
PG-101-NP	Pressure Gauge, Nickel-Plated

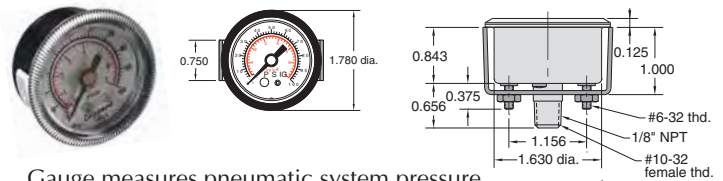

Gauge measures pneumatic system pressure. Mounting bracket included.

Input Pressure: Scale reading from 0 to 100 psig and 0 to 6.9 bar

Construction: Nickel-plated steel case. Plastic face. Dial shows two ranges; psig in black. Bars in red. Built-in pressure snubber.

Ports: Connection located at rear is double threaded O.D. - male thread 1/8" NPT I.D. - tapped for #10-32 fitting

Mounting: With zinc plated steel bracket supplied

Part No.	Description
PG-100	Pressure Gauge

6-Digit Pneumatic Totalizing Counter



The PT-1SM is a 6-digit pneumatic totalizing counter. A pneumatic signal or impulse adds the value of 1 to the display. When the indicator reaches its maximum value, the counter starts again at zero. The counter may be reset manually by depressing the reset push button, or by an air impulse. The counter is useful for event recording, piece or part counting, for indicating program steps, cycle counting, machine time logging, and many other purposes. The PT-1SM is designed for surface mounting.

Display: 6 figures, numerals 0.080" to 0.160"

Medium: Filtered compressed air containing no oil

Reset: Manual push button and pneumatic spring return

Input Pressure: 30 to 120 psig

Mounting: Surface mount

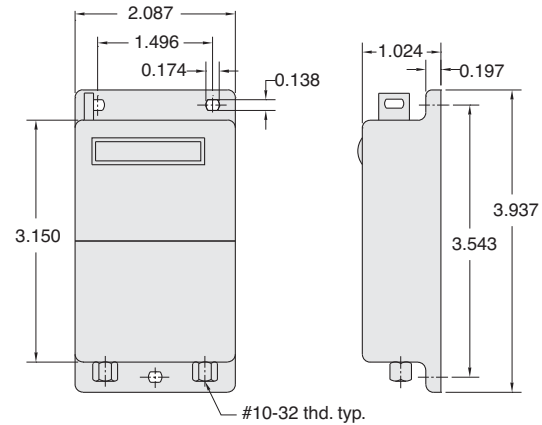

Part No.	Description
PT-1SM	6-Digit Pneumatic Totalizing Counter

Pneumatic Counter Solutions

Pneumatic counters are used in a variety of pneumatic applications including filling machines, cut counting, stamping, multi-spindle operations and more. They count pulses generated by cylinders, push buttons, pedals, and other actuation devices.

Clippard's 6-digit totalizing counter can be found in many places throughout their manufacturing operations.

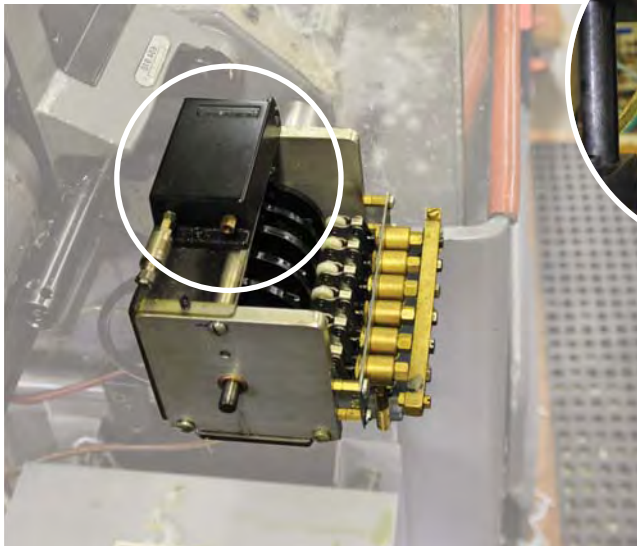

4-Spindle Turret Operation

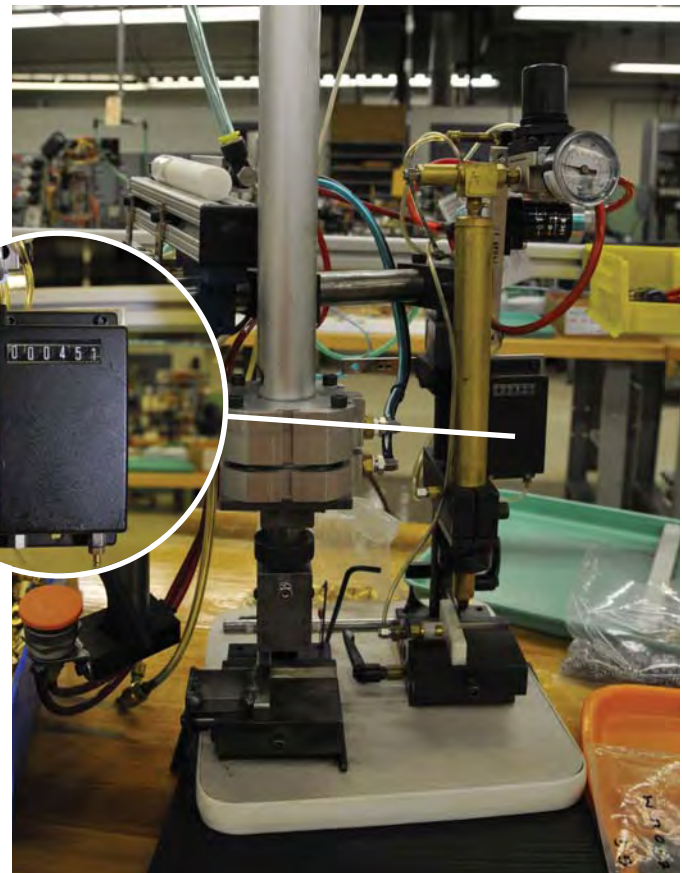

Date Stamping Operation

Non-Contact Air Proximity Switch



Non-Contact Air Proximity Switch with no moving parts; will sense any flat or curved object which presents a sensing surface of 1/4" or more to the sensing nozzle

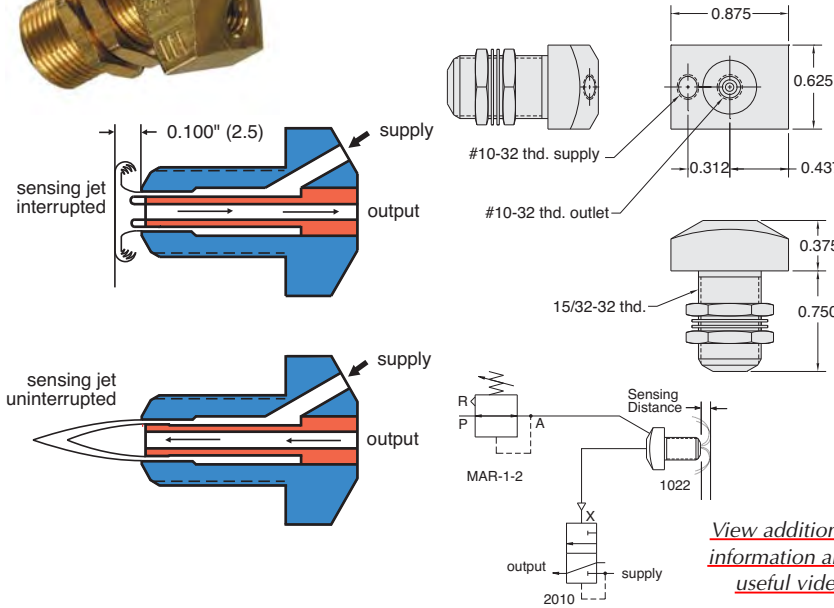

Medium: Air
Input Pressure: 4 to 10 psig
Nominal Proximity Distance: 0.100"
Output Signal at 4 psig supply: Normal: -2" H₂O
 actuated: 7 1/2" H₂O
Frequency Response: 500 CPM
Air Consumption: 0.3 scfm
Sensing Capability: Flat or curved surfaces with 1/8" minimum radius
Connections: #10-32 female
Construction: Solid brass bright dipped

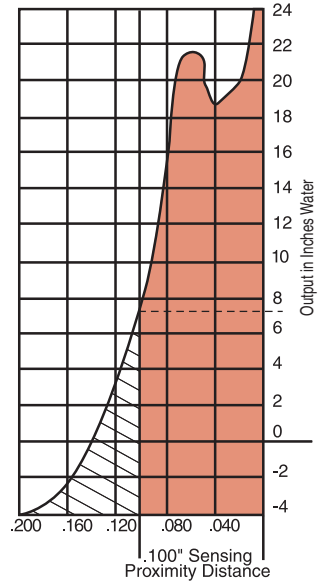

[View additional information and useful videos](#)

Part No.	Description
1022	Non-Contact Air Limit Switch, #10-32

Non-Contact Gap Sensor



Non-Contact Gap Sensor will sense any flat or round object with a 1/32" minimum radius. Produces a positive signal when no object is present and a negative signal when an object interrupts its sensing system

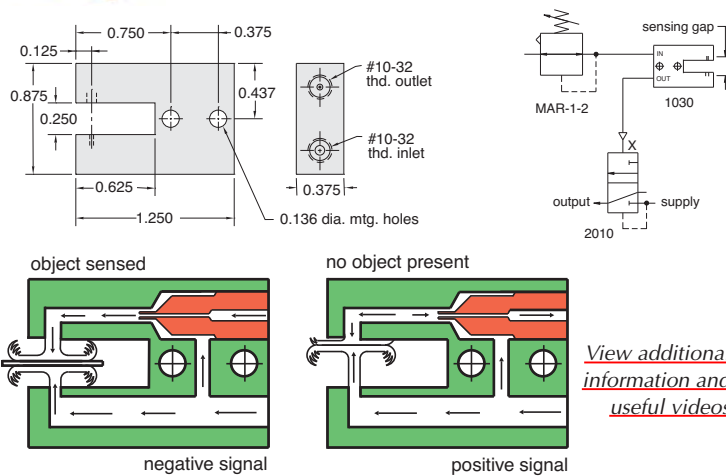

Medium: Air
Input Pressure: 0.5 to 5 psig
Output: -3" to 26" H₂O @ 4 psig
Frequency Response: 1,000 cpm
Air Consumption: 1/4 scfm @ 4 psig
Sensing Capability: Flat or curved surfaces with 1/32" minimum radius. May be used for up to 4" gap with an additional auxiliary jet
Connections: #10-32 female
Construction: Solid brass bright dipped

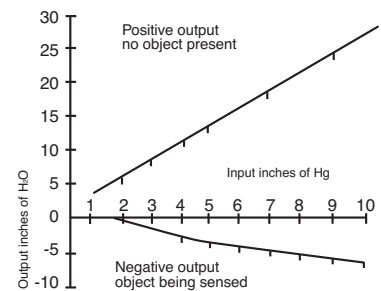

[View additional information and useful videos](#)

Part No.	Description
1030	Non-Contact Positive Pressure Sensor, #10-32

Normally-On Single Stage Pressure Repeater



Normally-On Single Stage Pressure Repeater for off-on control of an adjustable reference pressure when a sensed pressure moves above or below the reference pressure level

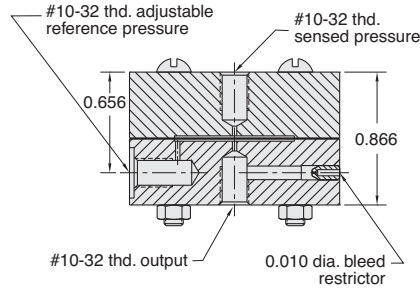
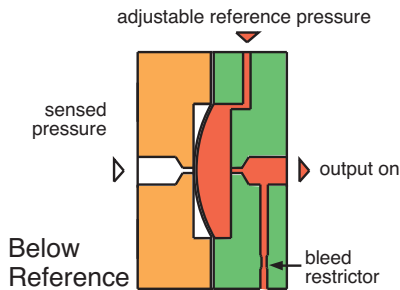
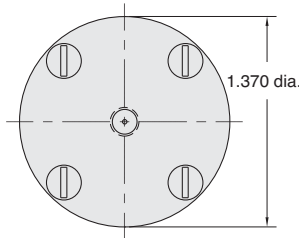

Medium: Reference pressure - air sensed pressure - Air, gas, or liquid

Input Pressure: 1 to 150 psig max.

Air Flow: 0.029" orifice

Response Time: 5 milliseconds

Differential Sensitivity: 2%

Frequency Response: 60 Hz

Materials: Anodized aluminum body, Nitrile diaphragms

Part No.	Description
1043	Single Stage Pressure Repeater

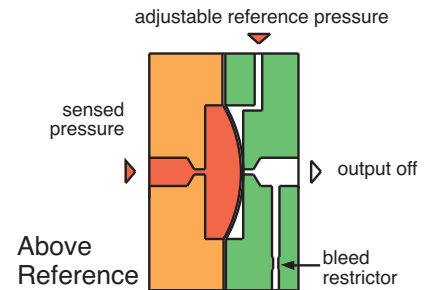

Normally-Off Two Stage Pressure Repeater



Normally Off Two Stage Pressure Repeater for off-on control of an adjustable reference pressure when a sensed pressure moves above or below the reference pressure level

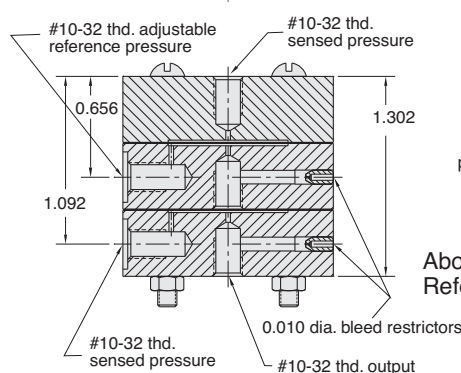
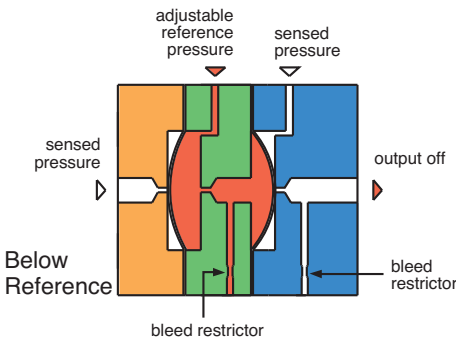
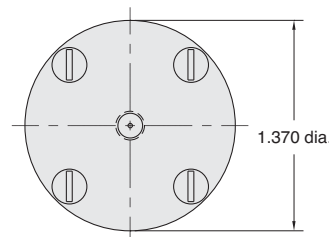

Medium: Reference pressure - air sensed pressure - Air, gas, or liquid

Input Pressure: 1 to 150 psig max.

Air Flow: 0.029" orifice

Response Time: 5 milliseconds

Differential Sensitivity: 2%

Frequency Response: 60 Hz

Materials: Anodized aluminum body, Nitrile diaphragms

Part No.	Description
1044	Two Stage Pressure Repeater

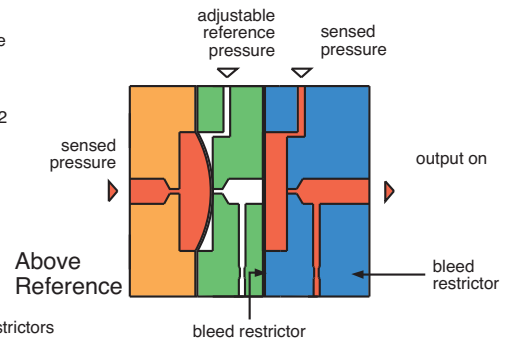

3-Way Normally-Closed Amplifier Valves



3-Way Valve Normally-Closed Interface amplifies very low pressure air-jet sensing signals to working power levels

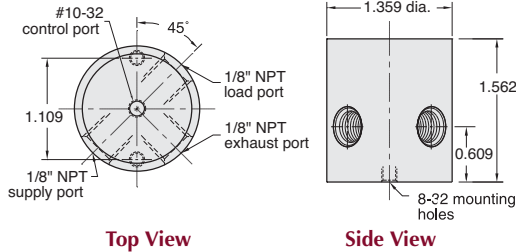

Top View

Side View

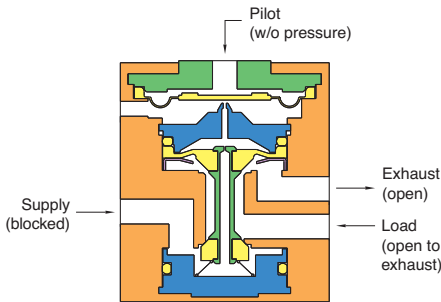

Valve Closed

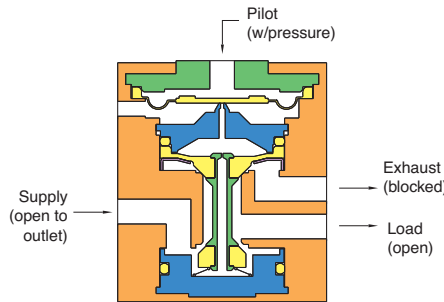

Valve Open

Medium: Air

Material: Anodized aluminum body, Nitrile diaphragms

Input Pressure: 30 to 100 psig

Air Flow: 22 scfm @ 100 psig;

Pilot Pressure: 4" H₂O @ 100 psig

Maximum Allowable Pilot Pressure: 5 psig

Response Time: 10 milliseconds dead headed

Operating Speed: 50 Hz

Bleed: 0.1 scfm @ 100 psig

Ports: Load - 1/8" NPT female
Supply - 1/8" NPT female
Exhaust - 1/8" NPT female
Control - #10-32 female

Part No.	Description
2010	Normally-Closed Interface, 1/8" NPT

3-Way Bleed Pressure Piloted Limit Valves



3-Way Bleed Pressure Piloted Limit Valve; blocking of the sensing port causes rapid valve opening

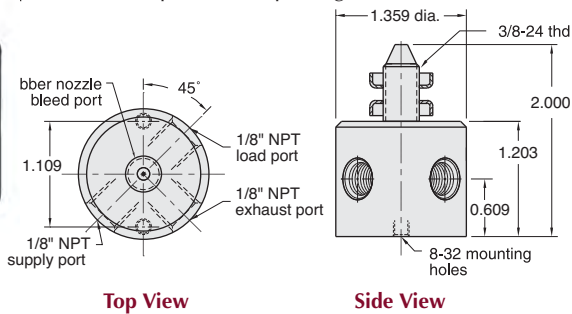

Top View

Side View

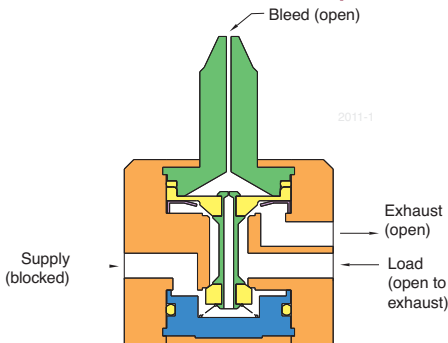

Valve Closed

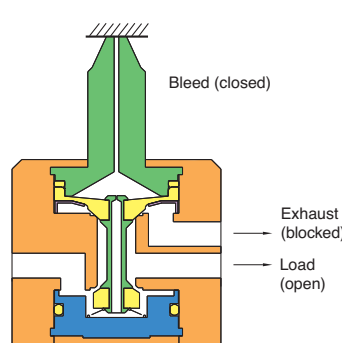

Valve Open

Medium: Air

Material: Anodized aluminum body, Nitrile diaphragms

Input Pressure: 30 to 100 psig max.

Air Flow: 22 scfm @ 100 psig;

Bleed: 0.1 scfm @ 100 psig

Response Time: 15 milliseconds

Ports: 1/8" NPT

Part No.	Description
2011-1	Piloted Limit Valve, 1/8" NPT



Rubber Nozzles
#10-32 rubber nozzles for replacement 2011-1 limit valves. #10-32 thread, five to a package

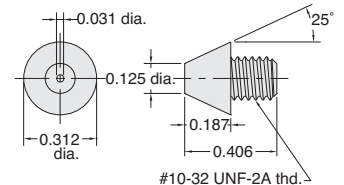

Part No.	Description
2011-012	Rubber Nozzles

Note: Supplied with threaded bulkhead mount and integral rubber nozzle for direct actuation by mechanical closure. By removing rubber nozzle and inserting a #10-32 fitting and length of hose, 2011-1 can be converted to a remote sensing valve.

3-Way N.O. or N.C. Air-Piloted Valves

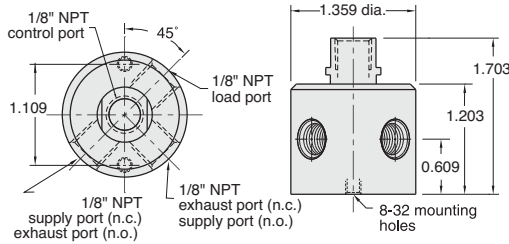

Top View

Side View

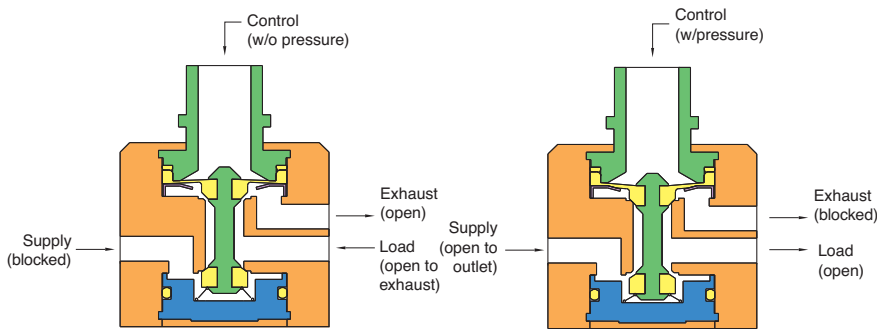

Valve Closed

Valve Open

Medium: Air

Material: Anodized aluminum body, Nitrile diaphragms

Input Pressure: 1 to 100 psig max.

Air Flow: 22 scfm @ 100 psig;

Minimum Pilot Pressure:

- N.O. - 90% of supply pressure
- N.C. - 60% of supply pressure

Response Time: 15 milliseconds after pilot pressure reaches switch point

Operating Speed: 1,100 CPM

Part No.	Description
2012	Piloted Valve, 1/8" NPT
2012-VAC	Valve for Vacuum Operation (requires positive pressure pilot signal)
2012-G	Valve for Liquid Adhesives (silicone diaphragm and seals), 1/8" NPT

Flat Bracket

Flat mounting bracket available. See page 146.



Part No.	Description
2010-050	Flat Bracket

3-Way N.O. or N.C. Electronically Piloted Valves



3-Way Normally-Closed Electronic Valve with low-power DC solenoid can be directly converted to high pressure pneumatic power without electronic amplification.

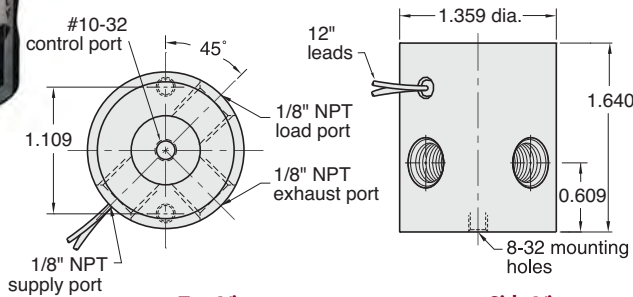

Top View

Side View

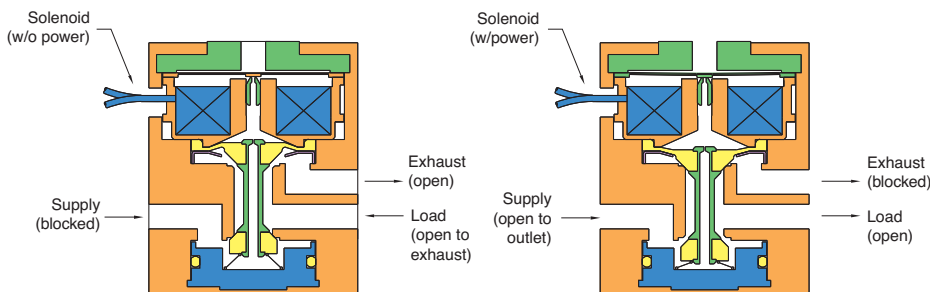

Valve Closed

Valve Open

Medium: Air

Material: Anodized aluminum body, Nitrile diaphragms

Input Pressure: 30 to 100 psig max.

Air Flow: 22 scfm @ 100 psig

Bleed: 0.1 scfm @ 100 psig

Filtration: 10 micron

Frequency Response: 50 Hz @ 100 psig
70 Hz @ 30 psig

Switching Speed: 10 milliseconds

Leads: 28 gauge stranded PVC insulated

Continuous Overload: 350% @ 25°C ambient; 250% @ 50°C ambient

Power Consumption: less than 0.50 watts at rated voltage
80 ma. @ 6V
40 ma. @ 12V
20 ma. @ 24V

Part No.	Description
2013-6	Valve, 6 Volts DC, 1/8" NPT
2013-12	Valve, 12 Volts DC, 1/8" NPT
2013-24	Valve, 24 Volts DC, 1/8" NPT

Flat Bracket

Flat mounting bracket available. See page 146.



Part No.	Description
2010-050	Flat Bracket

3-Way Normally-Closed Pressure Piloted Valve



Designed to be piloted by a Clippard EV or ET manifold mount electronic valve. Output from the EV/ET actuates the valve to produce outputs up to 22 scfm at 100 psig. Combines low wattage, long life and cool running of the EV/ET valves with quick response and high flow of Clippard booster type valves.

The 2020 and 2021 are identical in all respects except one. The 2020 has an external #10-32 port for the pressure supply to the EV/ET electronic pilot valve. The 2021 has an internal pressure supply to the EV/ET.

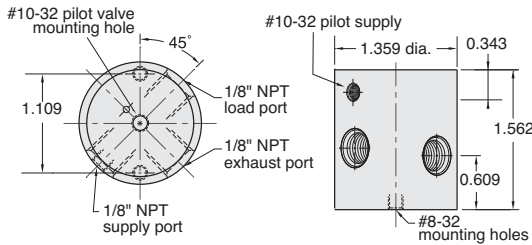

Top View

Side View



2020 shown with ET Pilot Valve and external pilot supply

Medium: Air

Input Pressure: 30 to 100 psig max.

Air Flow: 22 scfm @ 100 psig

Pilot Pressure: 60% of supply pressure, minimum

Response Time: Approx. 20 milliseconds

Mounting: Mounting holes provided

Materials: Anodized aluminum, stainless steel

Part No.	Description
2020	Piloted Valve, Ext. Port
2021	Piloted Valve, Int. Port

Part No.	Description
2013-6	Valve, 6 Volts DC, 1/8" NPT
2013-12	Valve, 12 Volts DC, 1/8" NPT
2013-24	Valve, 24 Volts DC, 1/8" NPT

Flat Bracket

Flat mounting bracket available. See page 146.



Part No.	Description
2010-050	Flat Bracket

Pressure Piloted Snap Action Amplifying Valve



Provides a sharp, clean output signal, even with slow-changing pressure input signals; output is stabilized without chatter or oscillation.

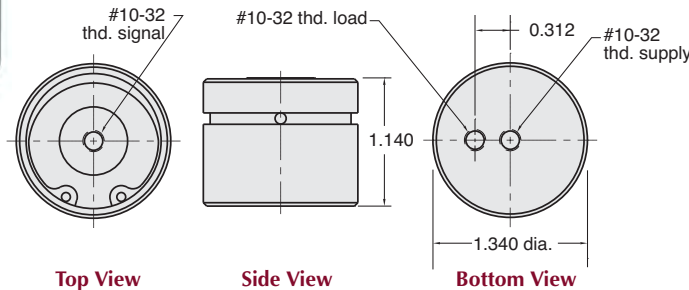

Top View

Side View

Bottom View

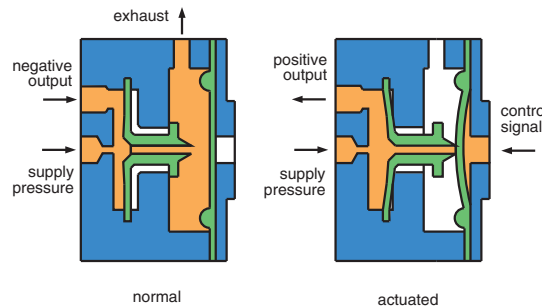

normal

actuated

Medium: Air

Input Pressure: 3 to 100 psig max.

Minimum Pilot Pressure: 1.5" H₂O psig

Maximum Pilot Pressure: 1 psig (28" H₂O)

Air Flow: 0.18 scfm @ 100 psig;

Bleed Orifice Diameter: 0.010"

Part No.	Description
3200-A	Amplifying Valve, #10-32

Bracket for Action Relays

Mounting bracket for snap action relays available. See page 146.



Part No.	Description
2010-050	Flat Bracket