



VALVE SELECTION CHARTS105 - 110

SMTV/SMAV SPOOL VALVES111

MINIATURE LIMIT VALVE111

MAV/MAVO STEM & CART. VALVES 112 - 113

MJV/MJVO STEM & CART. VALVES114

TV/TVO 2-WAY TOGGLE VALVES115

MTV TOGGLE VALVES116

PAV/PAVO AIR-PILOTED VALVES117

MJTV TOGGLE VALVES118

FV SPOOL VALVES119 - 120

FTV TOGGLE VALVES121

NEW! HV STEM & TOGGLE VALVES122

NEW! GV POPPET VALVES123

TV 4-WAY TOGGLE VALVES124

FBV FILL & BLEED VALVES125

SLEEVE VALVES126

HEAVY-DUTY LIMIT VALVES127

MAXIMATIC® VALVES128 - 131

PALM BUTTON VALVES132

MANUALLY-OPERATED VALVES133 - 134

VALVE ACTUATORS135 - 138

PUSH BUTTON ACTUATORS139 - 141

ASSEMBLIES142 - 145

VALVE MOUNTING BRACKETS146



Every air system is unique . . . and Clippard has the air valve you need. Clippard control valves are available in poppet or spool design; 2-, 3-, or 4-way functions, in sizes from #3-56 and #10-32 through 1/8" NPT ports; and for pressures to 300 psig. They are available with solenoid, air pilot, manual and mechanical actuators. Mounting styles include in-line, panel mount, manifold mount or clearance holes for mounting screws.

When designing a pneumatic system, choose the proper size for each component. A valve of insufficient capacity may cause an entire system to operate slower than expected. Conversely, utilizing a valve which possesses greater capacity than is actually required results in needless size and often leads to excessive speed, impact, wear, and air consumption.

The chart below shows the variety of valve flows available from Clippard. It can be used as a guide to determine the proper valve for an actual application.

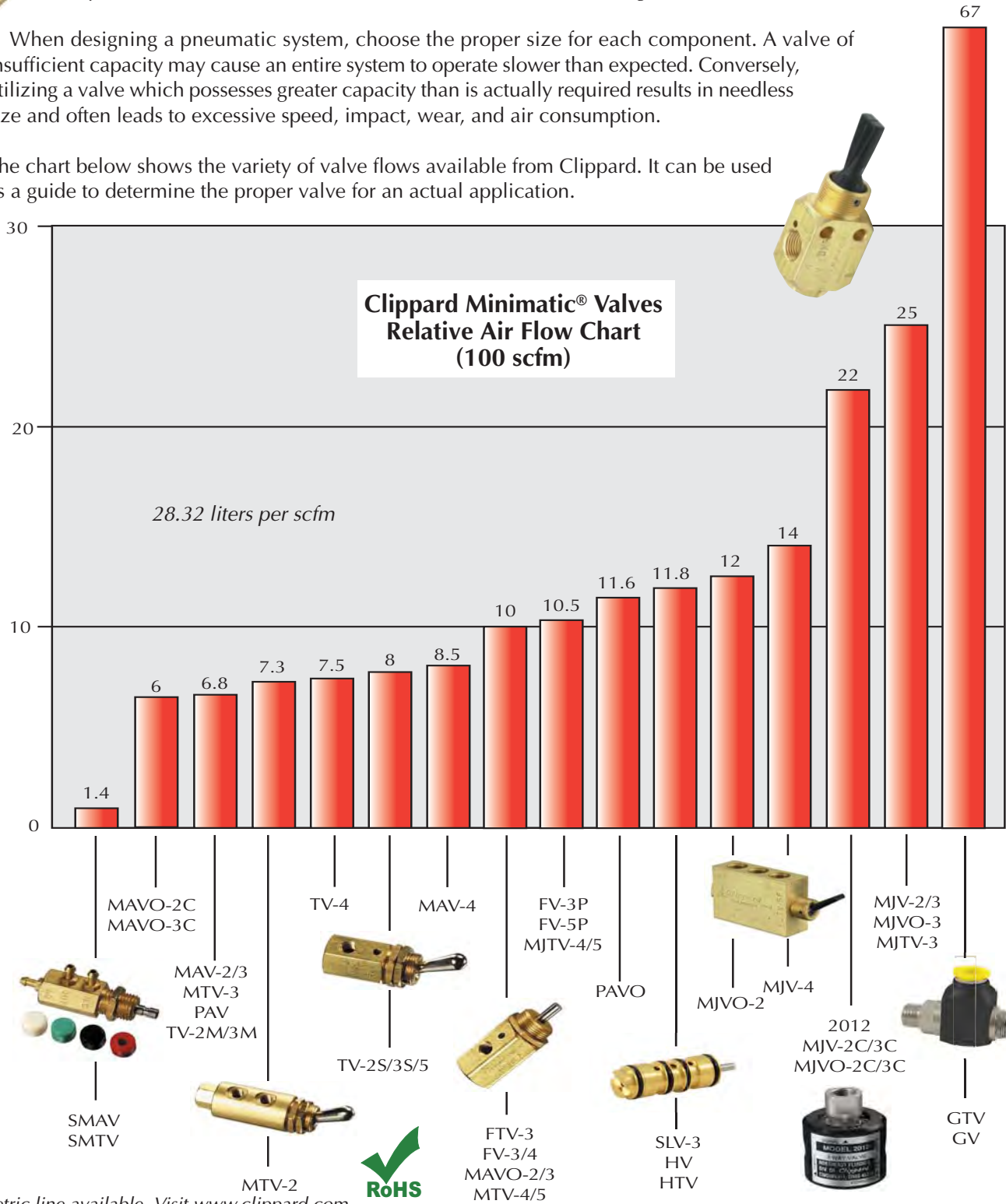

2-Way Toggle, Stem & Air-Piloted Valves

	Order No.	Style	Flow (@ 100 psig)	Ports			Normally-Open	Normally-Closed	Momentary//Detented	ENP Steel Toggle	Plastic Toggle	Page No.
				Inlet	Outlet	Exhaust						
Toggle Valves	GTV-2	Poppet	67 scfm	1/4" NPT	1/4" NPT	-	▲		▲		123	
	GTV-2Q	Poppet	67 scfm	1/4" NPT	1/4" NPT	-	▲		▲		123	
	GTV-2-P12	Poppet	67 scfm	3/8" PQ	3/8" PQ	-	▲		▲		123	
	GTV-2Q-P12	Poppet	67 scfm	1/4" NPT	3/8" PQ	-	▲		▲		123	
	MTV-2	Poppet	7.3 scfm	#10-32	#10-32	-	▲	D	▲		116	
	MTV-2P	Poppet	7.3 scfm	1/8" NPT	#10-32	-	▲	D	▲		116	
	TV-2S	Spool	8 scfm	#10-32	#10-32	-	▲	D	▲		115	
	TV-2SF	Spool	8 scfm	#10-32	#10-32	-	▲	D		▲	115	
	TV-2SP	Spool	8 scfm	1/8" NPT	#10-32	-	▲	D	▲		115	
	TV-2SFP	Spool	8 scfm	1/8" NPT	#10-32	-	▲	D		▲	115	
	TV-2M	Poppet	8 scfm	#10-32	#10-32	-	▲	M	▲		115	
	TV-2MF	Poppet	8 scfm	#10-32	#10-32	-	▲	M		▲	115	
	TV-2MP	Poppet	6.8 scfm	1/8" NPT	#10-32	-	▲	M	▲		115	
	TV-2MFP	Poppet	6.8 scfm	1/8" NPT	#10-32	-	▲	M		▲	115	
	TVO-2M	Spool	8 scfm	#10-32	#10-32	-	▲		M	▲	115	
	TVO-2MF	Spool	8 scfm	#10-32	#10-32	-	▲		M		▲	115
TVO-2MP	Spool	6.8 scfm	1/8" NPT	#10-32	-	▲		M	▲	115		
TVO-2MFP	Spool	6.8 scfm	1/8" NPT	#10-32	-	▲		M		▲	115	
Stem Valves	GV-2	Poppet	67 scfm	1/4" NPT	1/4" NPT	-		▲			123	
	GV-2Q	Poppet	67 scfm	1/4" NPT	1/4" NPT	-		▲			123	
	GV-2Q-P12	Poppet	67 scfm	1/4" NPT	3/8" PQ	-		▲			123	
	GV-2-P12	Poppet	67 scfm	3/8" PQ	3/8" PQ	-		▲			123	
	GV-2C	Poppet	67 scfm	Cartridge	Cartridge	-		▲			123	
	MAV-2	Poppet	6.8 scfm	#10-32	#10-32	-		▲			112	
	MAV-2P	Poppet	6.8 scfm	1/8" NPT	#10-32	-		▲			112	
	MAV-2C	Poppet	6 scfm	Cartridge	Cartridge	-		▲			112	
	MJV-2C	Poppet	22 scfm	Cartridge	Cartridge	-		▲			113	
	MAV-2R	Poppet	6.8 scfm	#10-32	#10-32	-		▲			112	
	MAVO-2	Spool	10 scfm	#10-32	#10-32	-	▲				112	
	MAVO-2P	Spool	10 scfm	1/8" NPT	#10-32	-	▲				112	
	MAVO-2C	Spool	10 scfm	Cartridge	Cartridge	-	▲				113	
	MJV-2	Poppet	25 scfm	1/8" NPT	1/8" NPT	-		▲			114	
	MJVO-2	Spool	12 scfm	1/8" NPT	1/8" NPT	-	▲				114	
MJVO-2C	Spool	15 scfm	Cartridge	Cartridge	-	▲				114		
Air-Piloted	PAV-2	Poppet	6.8 scfm	#10-32	#10-32	-		▲			117	
	PAV-2P	Poppet	6.8 scfm	1/8" NPT	#10-32	-		▲			117	
	PAVO-2	Spool	11.6 scfm	#10-32	#10-32	-	▲				117	
	PAVO-2P	Spool	11.6 scfm	1/8" NPY	#10-32	-	▲				117	

3-Way Toggle Valves

Order No.	Style	Flow (@ 100 psig)	Ports			Normally-Open	Normally-Closed	Momentary/Detented	ENP Steel Toggle	Plastic Toggle	Page No.
			Inlet	Outlet	Exhaust						
FTV-3	Spool	10 scfm	#10-32	#10-32	#10-32		▲	D	▲		121
FTV-3F	Spool	10 scfm	#10-32	#10-32	#10-32		▲	D		▲	121
FTV-3P	Spool	10.5 scfm	1/8" NPT	1/8" NPT	1/8" NPT		▲	D	▲		121
FTV-3FP	Spool	10.5 scfm	1/8" NPT	1/8" NPT	1/8" NPT		▲	D		▲	121
GTV-3	Poppet	67 scfm	1/4" NPT	1/4" NPT	hole in body		▲		▲		123
GTV-3Q	Poppet	67 scfm	1/4" NPT	1/4" NPT	hole in body		▲		▲		123
GTV-3-P12	Poppet	67 scfm	3/8" PQ	3/8" PQ	hole in body		▲		▲		123
GTV-3Q-P12	Poppet	67 scfm	1/4" NPT	3/8" PQ	hole in body		▲		▲		123
HTV-3	Spool	11.8 scfm	#10-32	#10-32	hole in body	▲	▲		▲		122
HTV-3F	Spool	11.8 scfm	#10-32	#10-32	hole in body	▲	▲			▲	122
HTV-3C	Cartridge	11.8 scfm	Cartridge	Cartridge	hole in body	▲	▲		▲		122
HTV-3CF	Cartridge	11.8 scfm	Cartridge	Cartridge	hole in body	▲	▲			▲	122
MTV-3	Poppet	7 scfm	#10-32	#10-32	#10-32		▲	D	▲		116
MTV-3P	Poppet	7 scfm	1/8" NPT	#10-32	#10-32		▲	D	▲		116
MJTV-3	Poppet	25 scfm	1/8" NPT	1/8" NPT	1/8" NPT		▲	D	▲		118
TV-3S	Spool	8 scfm	#10-32	#10-32	hole in body		▲	D	▲		124
TV-3SF	Spool	8 scfm	#10-32	#10-32	hole in body		▲	D		▲	124
TV-3SP	Spool	8 scfm	1/8" NPT	#10-32	hole in body		▲	D	▲		124
TV-3SFP	Spool	8 scfm	1/8" NPT	#10-32	hole in body		▲	D		▲	124
TV-3M	Poppet	6.8 scfm	#10-32	#10-32	hole in body		▲	M	▲		124
TV-3MF	Poppet	6.8 scfm	#10-32	#10-32	hole in body		▲	M		▲	124
TV-3MP	Poppet	6.8 scfm	1/8" NPT	#10-32	hole in body		▲	M	▲		124
TV-3MFP	Poppet	6.8 scfm	1/8" NPT	#10-32	hole in body		▲	M		▲	124
TVO-3M	Spool	6.8 scfm	#10-32	#10-32	hole in body	▲		M	▲		124
TVO-3MF	Spool	6.8 scfm	#10-32	#10-32	hole in body	▲		M		▲	124
TVO-3MP	Spool	6.8 scfm	1/8" NPT	#10-32	hole in body	▲		M	▲		124
TVO-3MFP	Spool	6.8 scfm	1/8" NPT	#10-32	hole in body	▲		M		▲	124
SMTV-3	Spool	1.4 scfm	#3-56*	#3-56*	hole in body	▲	▲	D	▲		111

Toggle Valves

* With hose barbs uninstalled



3-Way Stem Valves

Order No.	Style	Flow (@ 100 psig)	Ports			Normally-Open	Normally-Closed	Momentary/Detented	ENP Steel Toggle	Plastic Toggle	Page No.
			Inlet	Outlet	Exhaust						
FV-3	Spool	10 scfm	#10-32	#10-32	#10-32	▲	▲				119
FV-3D	Spool	10 scfm	#10-32	#10-32	#10-32	▲	▲				119
FV-3DP	Spool	10.5 scfm	1/8" NPT	1/8" NPT	1/8" NPT	▲	▲				119
FV-3P	Spool	10.5 scfm	1/8" NPT	1/8" NPT	1/8" NPT	▲	▲				119
GV-3	Poppet	67 scfm	1/4" NPT	1/4" NPT	hole in stem		▲				123
GV-3Q	Poppet	67 scfm	1/4" NPT	1/4" NPT	hole in stem		▲				123
GV-3-P12	Poppet	67 scfm	3/8" PQ	3/8" PQ	hole in stem		▲				123
GV-3Q-P12	Poppet	67 scfm	1/4" NPT	3/8" PQ	hole in stem		▲				123
GV-3C	Poppet	67 scfm	Cartridge	Cartridge	hole in stem		▲				123
HV-3	Spool	11.8 scfm	#10-32	#10-32	hole in body		▲				122
HV-3C	Cartridge	11.8 scfm	Cartridge	Cartridge	hole in body	▲	▲				122
MAV-3	Poppet	6.8 scfm	#10-32	#10-32	through stem		▲				112
MAV-3P	Poppet	6.8 scfm	1/8" NPT	#10-32	through stem		▲				112
MAV-3C	Poppet	6 scfm	Cartridge	Cartridge	through stem		▲				113
MAV-3R	Poppet	6.8 scfm	#10-32	#10-32	through stem		▲				112
MAVO-3	Spool	10 scfm	#10-32	#10-32	holes in body	▲					112
MAVO-3P	Spool	10 scfm	1/8" NPT	#10-32	holes in body	▲					112
MAVO-3C	Spool	10 scfm	Cartridge	Cartridge	holes in body	▲					113
MJV-3	Poppet	25 scfm	1/8" NPT	1/8" NPT	through stem		▲				114
MJV-3C	Poppet	22 scfm	Cartridge	Cartridge	through stem		▲				114
MJVO-3	Spool	12 scfm	1/8" NPT	1/8" NPT	holes in body	▲					114
MJVO-3C	Spool	15 scfm	Cartridge	Cartridge	holes in body	▲					114
SMAV-3	Spool	1.4 scfm	#3-56	#3-56	#3-56	▲	▲				111
PAV-3	Poppet	6.8 scfm	#10-32	#10-32	holes in body		▲				117
PAV-3P	Poppet	6.8 scfm	1/8" NPT	#10-32	holes in body		▲				117
PAVO-3	Spool	11.6 scfm	#10-32	#10-32	holes in body	▲					117
PAVO-3P	Spool	11.6 scfm	1/8" NPT	#10-32	holes in body	▲					117

All valves above are RoHS Compliant

4-Way Toggle & Stem Valves

	Order No.	Style	Flow (@ 100 psig)	Ports			Normally-Open	Normally-Closed	Momentary/Detented	ENP Steel Toggle	Plastic Toggle	Page No.
				Inlet	Outlet	Exhaust						
Toggle Valves	HTV-4	Spool	11.8 scfm	#10-32	#10-32	atmos. or hole	▲		▲			122
	HTV-4F	Spool	11.8 scfm	#10-32	#10-32	atmos. or hole	▲			▲		122
	HTV-4C	Cartridge	11.8 scfm	Cartridge	Cartridge	atmos. or hole	▲		▲			122
	HTV-4CF	Cartridge	11.8 scfm	Cartridge	Cartridge	atmos. or hole	▲			▲		122
	TV-4D	Spool	7.5 scfm	#10-32	#10-32	holes in body	▲	D	▲	▲		124
	TV-4M	Spool	7.5 scfm	#10-32	#10-32	holes in body	▲	D	▲	▲		124
	TV-4DM	Spool	7.5 scfm	#10-32	#10-32	holes in body	▲	D	▲	▲		124
	TV-4DP	Spool	7.5 scfm	1/8" NPT	1/8" NPT	holes in body	▲	D	▲	▲		124
	TV-4MP	Spool	7.5 scfm	1/8" NPT	1/8" NPT	holes in body	▲	D	▲	▲		124
	TV-4DMP	Spool	7.5 scfm	1/8" NPT	1/8" NPT	holes in body	▲	D	▲	▲		124
	MTV-4	Spool	10 scfm	#10-32	#10-32	holes in body	▲	▲	D	▲		116
	MTV-4F	Spool	10 scfm	#10-32	#10-32	holes in body	▲	▲	D		▲	116
	MJTV-4	Spool	10.5 scfm	1/8" NPT	1/8" NPT	holes in body	▲	▲	D	▲		118
	MJTV-4F	Spool	10.5 scfm	1/8" NPT	1/8" NPT	holes in body	▲	▲	D		▲	118
	MTV-5	Spool	10 scfm	#10-32	#10-32	#10-32	▲	▲	D	▲		118
	MTV-5F	Spool	10 scfm	#10-32	#10-32	#10-32	▲	▲	D		▲	118
	MJTV-5	Spool	10.5 scfm	1/8" NPT	1/8" NPT	1/8" NPT	▲	▲	D	▲		118
MJTV-5F	Spool	10.5 scfm	1/8" NPT	1/8" NPT	1/8" NPT	▲	▲	D		▲	118	
Stem Valves	MAV-4	Spool	8.5 scfm	#10-32	#10-32	holes in body	▲	▲				112
	MAV-4D	Spool	8.5 scfm	#10-32	#10-32	holes in body	▲	▲				112
	MJV-4	Spool	14 scfm	1/8" NPT	1/8" NPT	holes in body	▲	▲				112
	MJV-4D	Spool	14 scfm	1/8" NPT	1/8" NPT	holes in body	▲	▲				112
	FV-4	Spool	10 scfm	#10-32	#10-32	holes in body	▲	▲				119
	FV-4P	Spool	10.5 scfm	1/8" NPT	1/8" NPT	holes in body	▲	▲				120
	FV-4D	Spool	10 scfm	#10-32	#10-32	holes in body	▲	▲				119
	FV-4DP	Spool	10.5 scfm	1/8" NPT	1/8" NPT	holes in body	▲	▲				120
	FV-5	Spool	10 scfm	#10-32	#10-32	#10-32	▲	▲				120
	FV-5P	Spool	10.5 scfm	1/8" NPT	1/8" NPT	1/8" NPT	▲	▲				120
	FV-5D	Spool	10 scfm	#10-32	#10-32	#10-32	▲	▲				120
	FV-5DP	Spool	10.5 scfm	1/8" NPT	1/8" NPT	1/8" NPT	▲	▲				120
	HV-4	Spool	11.8 scfm	#10-32	#10-32	atmosphere	▲	▲				122
	HV-4C	Cartridge	11.8 scfm	Cartridge	Cartridge	atmosphere	▲	▲				122



options (suffix)
ENP Plating “-ENP” • FKM Seals “-V”

-ENP Electroless Nickel Plating

This option provides a low luster finish on brass parts for decorative purposes that also protects the surface from corrosion and tarnishing. It has a nominal thickness of 0.0002”, and does not affect the fit or function of the part.

Metric

In order to accommodate applications around the globe, many Clippard Control Valves and other product lines are available with metric ports. Consult factory for availability.

-V FKM

This option replaces the standard Nitrile seals with FKM seals either for high temperature (up to + 400°F) applications or those that require Viton for chemical compatibility. Consult factory for availability.

Temperature Range

All Directional Control Valves in this section have a temperature range of 32 to 230°F.

CUSTOMer
solutions

If you need a product that fits your application perfectly, Clippard has the capability to design or modify one of its products to suit your exact needs. We understand that a standard catalog product may be close but not be exactly what you need. **Let us know YOUR Need, and we will help to find YOUR Solution!**

www.clippard.com/customsolutions

Alternate materials, seals and/or lubrication for specific applications are common (and welcomed) requests at Clippard. Stainless steel, aluminum, plastic or brass. All available, just ask!



Needle valves are common in controlling the flow of fluids and gases. This special needle valve uses a “D” stem for adapting to standard panel knobs. It also incorporates a special left-handed thread to provide a more intuitive clockwise movement to increase flow.

Clippard miniature valves and associated products have evolved into a widely used system of fluid power control devices, known for quality, value and performance.

Over the past five decades, a diverse range of industries in the U.S. and throughout the world have come to rely on Minimatics to



control machines, systems, and processes through an unlimited list of applications. Clippard quality in design, engineering, manufacturing, as well as an expansive product offering, make Minimatics the preferred choice for miniature and subminiature pneumatic applications.

Recognized as the original and most complete line of miniature pneumatic components, Clippard’s Minimatic line is available across the globe through a network of fully-trained, stocking distributors. Clippard and our distributors stand ready to provide expert application assistance, support, and technical answers, to help you achieve the highest level of performance in your system.



Clippard’s unparalleled history in providing new and innovative products continues today with advanced manufacturing machines and techniques, experienced design and application engineers, and a work

force that is not only experienced, but one that genuinely wants to exceed the customer’s expectations. We take great satisfaction in shipping you a quality products

A combination assembly using a toggle or push button operator and Clippard’s pressure-actuated electrical switches provides a simultaneous air and electrical output.



Maximatic® 3-Way & 4-Way Air-Piloted Valves

3-Way Valves

Series No.	Inlet	Ports Outlet	Exhaust	Function	Cv	Flow @ 100 psig	Page
MMA-31NAS	#10-32	#10-32	#10-32	3/2	0.58	27 scfm	128
MMA-31PAS	1/8" NPT	1/8" NPT	1/8" NPT	3/2	0.67	31 scfm	128
MMA-32QAS	1/4" NPT	1/4" NPT	1/8" NPT	3/2	0.89	49 scfm	128
MMA-33WAS	3/8" NPT	3/8" NPT	1/4" NPT	3/2	1.68	93 scfm	128
MMA-34ZAS	1/2" NPT	1/2" NPT	1/2" NPT	3/2	2.79	171 scfm	128
MMA-31NAA	#10-32	#10-32	#10-32	3/2	0.58	27 scfm	128
MMA-31PAA	1/8" NPT	1/8" NPT	1/8" NPT	3/2	0.67	31 scfm	128
MMA-32QAA	1/4" NPT	1/4" NPT	1/8" NPT	3/2	0.89	49 scfm	128
MMA-33WAA	3/8" NPT	3/8" NPT	1/4" NPT	3/2	1.68	93 scfm	128
MMA-34ZAA	1/2" NPT	1/2" NPT	1/2" NPT	3/2	2.79	171 scfm	128

4-Way Valves

Series No.	Inlet	Ports Outlet	Exhaust	Function	Cv	Flow @ 100 psig	Spool Configuration		
							Closed Center	Exhaust Center	Pressure Center
MMA-41NAS	#10-32	#10-32	#10-32	5/2	0.58	27 scfm			
MMA-41PAS	1/8" NPT	1/8" NPT	1/8" NPT	5/2	0.67	31 scfm			
MMA-42QAS	1/4" NPT	1/4" NPT	1/8" NPT	5/2	0.89	49 scfm			
MMA-43WAS	3/8" NPT	3/8" NPT	1/4" NPT	5/2	1.68	93 scfm			
MMA-44ZAS	1/2" NPT	1/2" NPT	1/2" NPT	5/2	2.79	171 scfm			
MMA-41NAA	#10-32	#10-32	#10-32	5/2	0.58	27 scfm			
MMA-41PAA	1/8" NPT	1/8" NPT	1/8" NPT	5/2	0.67	31 scfm			
MMA-42QAA	1/4" NPT	1/4" NPT	1/8" NPT	5/2	0.89	49 scfm			
MMA-43WAA	3/8" NPT	3/8" NPT	1/4" NPT	5/2	1.68	93 scfm			
MMA-44ZAA	1/2" NPT	1/2" NPT	1/2" NPT	5/2	2.79	171 scfm			
MMA-41NAAC	#10-32	#10-32	#10-32	5/3	0.50	23 scfm	•		
MMA-41PAAC	1/8" NPT	1/8" NPT	1/8" NPT	5/3	0.50	23 scfm	•		
MMA-42QAAC	1/4" NPT	1/4" NPT	1/8" NPT	5/3	0.89	49 scfm	•		
MMA-43WAAC	3/8" NPT	3/8" NPT	1/4" NPT	5/3	1.00	72 scfm	•		
MMA-44ZAAC	1/2" NPT	1/2" NPT	1/2" NPT	5/3	1.68	93 scfm	•		
MMA-41NAAP	#10-32	#10-32	#10-32	5/3	0.50	23 scfm			•
MMA-41PAAP	1/8" NPT	1/8" NPT	1/8" NPT	5/3	0.50	23 scfm			•
MMA-42QAAP	1/4" NPT	1/4" NPT	1/8" NPT	5/3	0.89	49 scfm			•
MMA-43WAAP	3/8" NPT	3/8" NPT	1/4" NPT	5/3	1.00	72 scfm			•
MMA-44ZAAP	1/2" NPT	1/2" NPT	1/2" NPT	5/3	1.68	93 scfm			•
MMA-41NAAE	#10-32	#10-32	#10-32	5/3	0.50	23 scfm		•	
MMA-41PAAE	1/8" NPT	1/8" NPT	1/8" NPT	5/3	0.50	23 scfm		•	
MMA-42QAAE	1/4" NPT	1/4" NPT	1/8" NPT	5/3	0.89	49 scfm		•	
MMA-43WAAE	3/8" NPT	3/8" NPT	1/4" NPT	5/3	1.00	72 scfm		•	
MMA-44ZAAE	1/2" NPT	1/2" NPT	1/2" NPT	5/3	1.68	93 scfm		•	

© Maximatic is a registered trademark of Clippard Instrument Laboratory, Inc.

SMTV/SMAV 3-56 Sub-Miniature Spool Valves

3-Way Toggle and Push Button Valve have 1/16" tube barbs. The push-button valve can be used as a normally open or normally closed 3-way. The miniature limit valve is designed to serve as a mechanical stop when the stem is fully depressed.

Medium: Air

Stem Travel: 1/16"

Input Pressure: 100 psig max.

Ports: 3-56 with 1/16" ID Hose Barbs

Air Flow: 1.4 scfm @ 100 psig

Force to Rotate Toggle: SMAV: 20 oz.; SMTV: 24 oz. nominal

Spool Material: Delrin® acetal resin

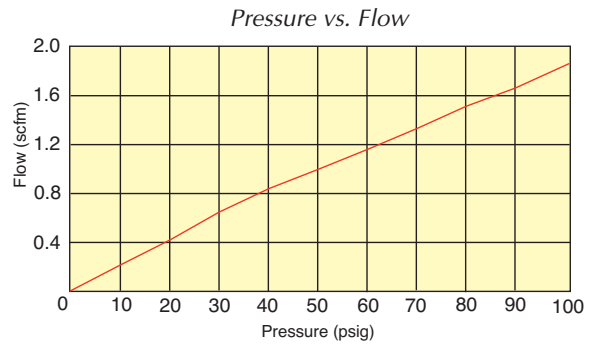

- Subminiature size spool design
- Multiple colored buttons for SMAV



Normally-Closed



Function	Part No.
Normally-Closed	<u>SMTV-3</u>

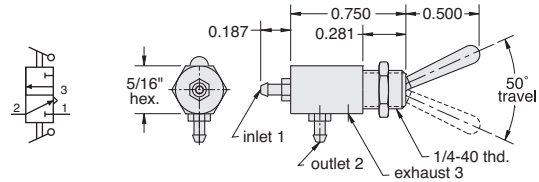

Normally-Open/Normally-Closed



Function	Part No.
N.O.-N.C.	<u>SMAV-3</u>

Four colors of snap-on push buttons included with each valve

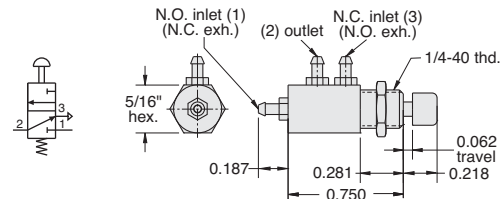

Miniature 3-Way Limit Valve

The MLV-3 is a 3-way, Normally-Closed limit valve designed to give dependable performance in a small, rugged package. The valve design is a poppet type with fast opening and high flow. Mounted on a machine or fixture, the valve will be actuated by any moving part that contacts and depresses the stem. The stem may be depressed flush with the body so there is no possibility of over-travel of the valve mechanism. The exhaust is to atmosphere through a hole in the valve stem.



Stem Travel: 1/8"

Input Pressure: 150 psig max.

Air Flow: 4 scfm @ 50 psig; 7 scfm @ 100 psig

Force for Full Stem Travel: 48 oz. nominal

Mounting: Dual #20 holes or 15/32-32 thd. Nut and lockwasher furnished

Part No.
<u>MLV-3</u>

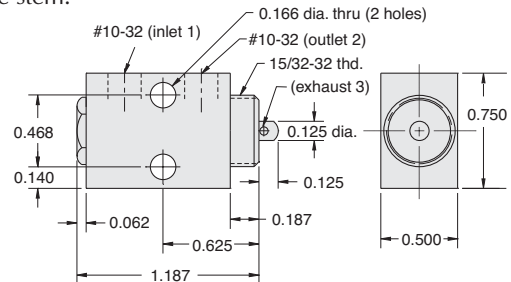

© Delrin® is a registered trademark of DuPont for its acetal resin

MAV/MAVO Stem Valves

2-Way, 3-Way & 4-Way Styles

The MAV series are #10-32 ported 2-way, 3-way and 4-way valves that change their flow path when the stem is either depressed or released. The 2-way and 3-way valves are offered in both Normally-Closed (not passing) or Normally-Open (passing) versions. The 4-way valves are typically used to control a double acting air cylinder. On pages 135 through 145 we offer a wide range of pneumatic and mechanical valve actuators that work with all Clippard stem valves.

Medium: Air, Water or Oil

Input Pressure: MAV-2, MAV-3: 300 psig max.;
MAVO-2, MAVO-3, MAV-4: 150 psig max

Stem Travel: MAV-2, MAV-3: 1/8"; MAV-4: 3/16"

Force For Full Stem Travel: MAV-2, MAV-3: 24 oz.; MAVO-2, MAVO-3: 32 oz.; MAV-4: 38 oz.; MAV-4D: 12 oz. nominal

Mounting: 15/32-32 thread. Nut and lockwashers furnished. Cartridge inserts into a 3/8" bore (0.375" ±0.001")

Materials: Brass body, Nitrile seals, stainless steel stem and spring

Pressure vs. Flow

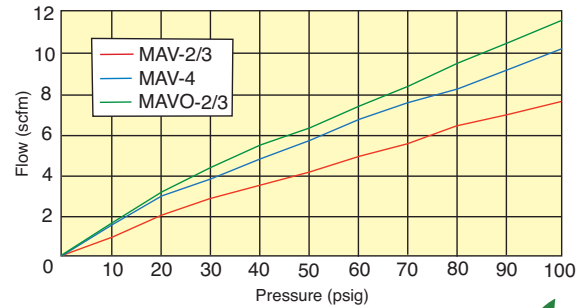

- Miniature size with high flow poppet or spool design
- Poppet valves have superior life and spool valves are more versatile.



Normally-Closed Poppet Valves



(MAV-3P shown)

Port(s)	Outlet	2-Way	3-Way
#10-32	#10-32	MAV-2	MAV-3
1/8" NPT	#10-32	MAV-2P	MAV-3P

Air Flow: 4 scfm @ 50 psig; 6.8 scfm @ 100 psig

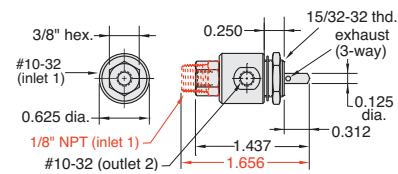

Normally-Closed Poppet Valve with Rotatable Inlet



(MAV-2R shown)

Port(s)	Outlet	2-Way	3-Way
#10-32	#10-32	MAV-2R	MAV-3R

Air Flow: 4 scfm @ 50 psig; 6.8 scfm @ 100 psig

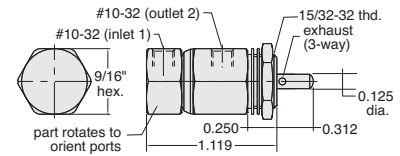

Normally-Open Spool Valves



(MAVO-2P shown)

Port(s)	Outlet	2-Way	3-Way
#10-32	#10-32	MAVO-2	MAVO-3
1/8" NPT	#10-32	MAVO-2P	MAVO-3P

Air Flow: 6 scfm @ 50 psig; 10 scfm @ 100 psig

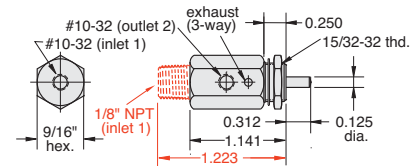

Normally-Closed Spool Valves



(MAV-4 shown)

Port(s)	Outlet	Actuation	4-Way
#10-32	#10-32	Spring Return	MAV-4
#10-32	#10-32	2-Position	MAV-4D

Air Flow: 5 scfm @ 50 psig; 8.5 scfm @ 100 psig

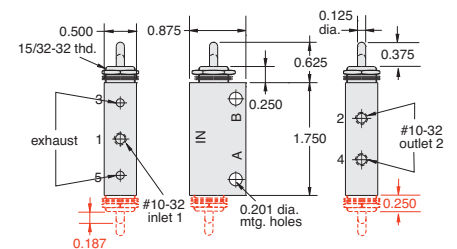

For high temperature applications (up to +400°F), or those that require special seals for chemical compatibility, Clippard offers optional FKM seals.

options (suffix)
ENP Plating "ENP" • FKM Seals "V"

MAV/MAVO Stem Valves Cont'd.

2-Way Cartridge Valves



(MAV-2C shown)

Function	2-Way
Normally-Closed	MAV-2C
Normally-Open	MAVO-2C

Air Flow: 3 scfm @ 50 psig; 6 scfm @ 100 psig

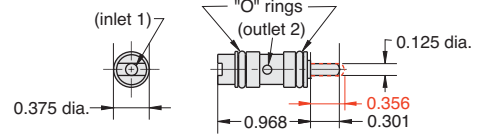

3-Way Cartridge Valves



(MAVO-3C shown)

Function	3-Way
Normally-Closed	MAV-3C
Normally-Open	MAVO-3C

Air Flow: 3 scfm @ 50 psig; 6 scfm @ 100 psig

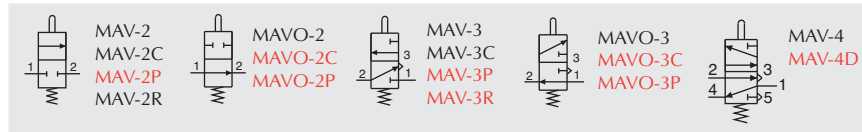
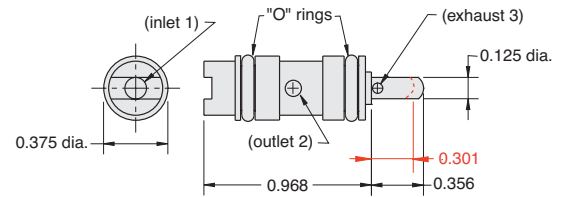

Cartridge Valve Mounting

Clippard miniature cartridge valves offer the user flexibility in the application of 2-way and 3-way Normally-Open or Normally-Closed valves. They are used in Clippard heavy-duty limit switches and are suitable for pneumatic tools and manifolds or for any use where a valve needs to be built in.

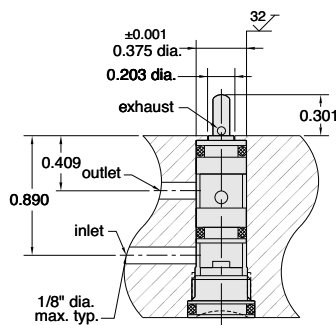

MAV-2C/3C

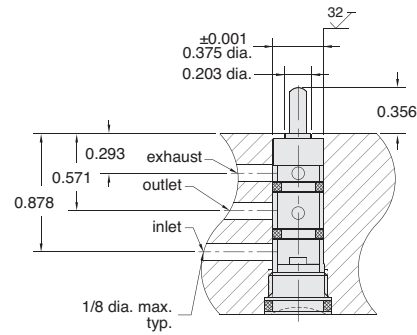

MAVO-2C/3C

Captivated Push Buttons



The small compact size make the push buttons adaptable to panel mounting. Unlike set screw retained buttons, the screw-on design will not allow the button to fall off. Designed to work with Clippard MAV, MJV, and FV series valves, these buttons also help protect the valve by preventing over-traveling of the stem and the potential for side-load on the valve. See [page 139](#) for more information.

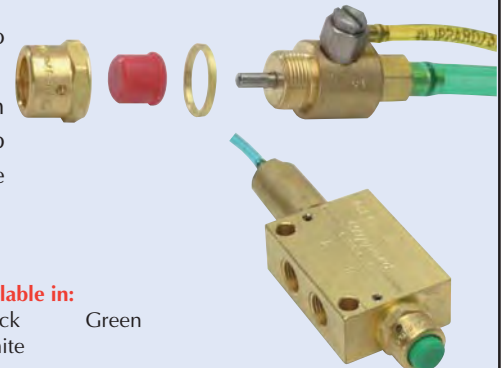

Button Housing Available in:

Black Chrome Electroless
Brass Nickel Plated

Button Colors Available in:

Yellow Black
Red White
Green

MJV-MJVO Stem & Cartridge Valves

These are high flow 1/8" NPT ported 2-way, 3-way and 4-way valves that change their flow path when the stem is either depressed or released (spring return). The 2-way and 3-way valves are offered in both Normally-Closed (not passing) or Normally-Open (passing) versions. The 4-way valves are typically used to control a double acting air cylinder. On pages 135 through 145 we offer a wide range of pneumatic and mechanical valve actuators that work with all Clippard stem valves.

Medium: Air, water, oil, or other compatible fluids

Input Pressure: MJVO-2, MJVO-3, MJV-4, MJV-4D: 150 psig max.;
MJV-2, MJV-3, MJVO-3C: 300 psig max.

Stem Travel: 1/8"; MJV-4: 3/16"

Force For Full Stem Travel: MJV-4D: 12 oz.; MJV-2C, MJVO-2C: 24 oz.; MJVO-2:
36 oz.; MJV-2, MJV-3, MJVO-3, MJV-4: 38 oz. nominal.

Mounting: 15/32-32 thread. Nut and lockwashers furnished. MJV-4 and MJV-4D also have two 0.201" diameter mounting holes in valve body. Cartridge version inserts into a 5/8" bore (0.625" ±0.001")

Materials: Brass body, Nitrile seals, stainless steel stem and spring

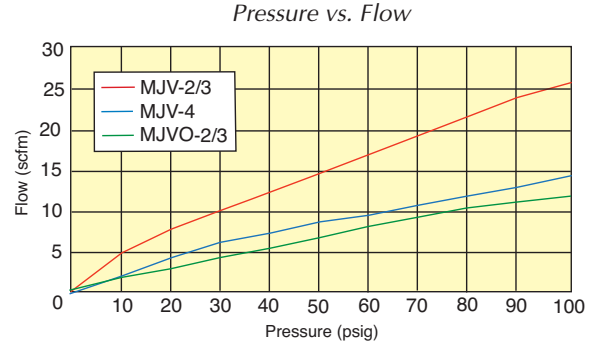

- High flow poppet or spool design
- MJV-2 or MJV-3 are Normally-Closed (no flow when not actuated)
- MJVO-2 or MJVO-3 are Normally-Open (flowing until actuated)
- Cartridge valves (suffix "-C") are designed to be installed in a custom bore.

Normally-Open/Normally-Closed Poppet Valves



(MJV-2 shown)

Port(s)	Function	2-Way	3-Way
1/8" NPT	Normally-Closed	MJV-2	MJV-3
1/8" NPT	Normally-Open	MJVO-2	MJVO-3

Air Flow:

MJV-2, MJV-3/MJVO-3: 14 scfm @ 50 psig;
25 scfm @ 100 psig;
MJVO-2: 7 scfm @ 50 psig; 12 scfm @ 100 psig;
14 scfm @ 50 psig; 25 psig @ 100 psig

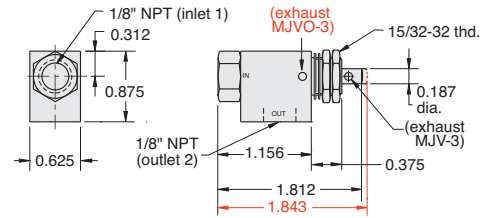

2-Way & 3-Way Cartridge Valves



(MJV-2C shown)

Function	2-Way	3-Way
Normally-Closed	MJV-2C	MJV-3C
Normally-Open	MJVO-2C	MJVO-3C

Air Flow: 11 scfm @ 50 psig; 22 scfm @ 100 psig

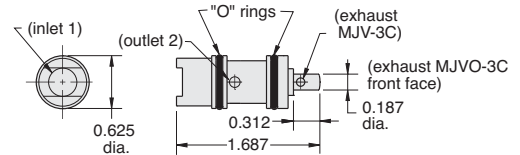

Normally-Open Spool Valves



(MJV-4D shown)

Port(s)	Actuation	4-Way
1/8" NPT	Spring Return	MJV-4
1/8" NPT	2-Position	MJV-4D

Air Flow: 8 scfm @ 50 psig; 14 scfm @ 100 psig

Mounting: Also two 0.201" dia. mounting holes in valve body

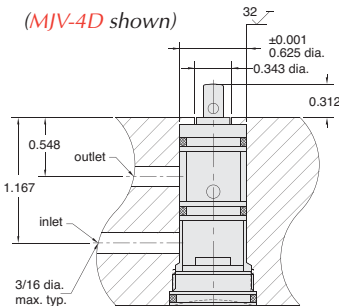
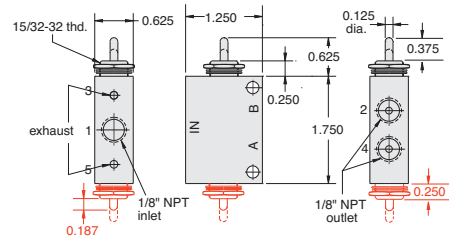

MJV-2C/3C, MJVO-2C/3C

options (suffix)
ENP Plating "ENP" • FKM Seals "Y"

Clippard miniature **Cartridge Valves** offer the user flexibility in the application of 2-way and 3-way Normally-Open or Normally-Closed valves. They are used in Clippard heavy-duty limit switches and are suitable for pneumatic tools and manifolds or for any use where a valve needs to be built in.

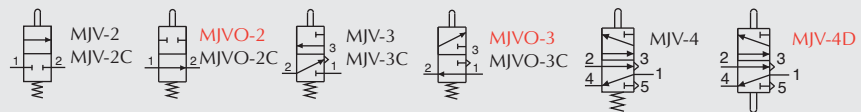

TV/TVO 2-Position Toggle Valves

2-Way & 3-Way Styles

The function of a 2-way valve is to turn an air supply on and off. In the "on" position, medium flows from inlet to outlet, and in the "off" position, the flow is blocked. 3-way styles have an exhaust port which vents the outlet to atmosphere.

Medium: Air, Water or Oil

Input Pressure: 150 psig max.

Force to Rotate Toggle: 12 oz. nominal

Mounting: 15/32-32 thread. Nut and lockwashers furnished.

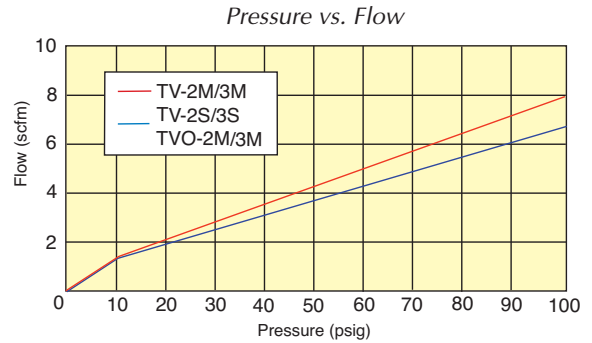

- Normally-Open or Normally-Closed
- Brass body, Nitrile seals, stainless steel stem and spring
- Steel or plastic toggles

Normally-Closed Poppet Valves with Momentary Actuation

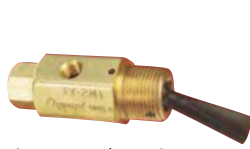

Port(s)	Toggle	2-Way	3-Way
#10-32	ENP Steel	<u>TV-2M</u>	<u>TV-3M</u>
#10-32	Plastic	<u>TV-2MF</u>	<u>TV-3MF</u>
1/8" NPT	ENP Steel	<u>TV-2MP</u>	<u>TV-3MP</u>
1/8" NPT	Plastic	<u>TV-2MFP</u>	<u>TV-3MFP</u>

Air Flow: 4.0 scfm @ 50 psig; 6.8 scfm @ 100 psig

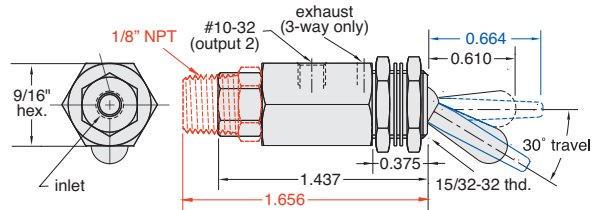

Normally-Closed Spool Valves with Detented Actuation



Port(s)	Toggle	2-Way	3-Way
#10-32	ENP Steel	<u>TV-2S</u>	<u>TV-3S</u>
#10-32	Plastic	<u>TV-2SF</u>	<u>TV-3SF</u>
1/8" NPT	ENP Steel	<u>TV-2SP</u>	<u>TV-3SP</u>
1/8" NPT	Plastic	<u>TV-2SFP</u>	<u>TV-3SFP</u>

Air Flow: 4.5 scfm @ 50 psig; 8 scfm @ 100 psig

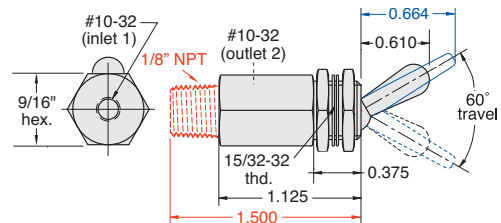

Normally-Open Spool Valves with Momentary Actuation



Port(s)	Toggle	2-Way	3-Way
#10-32	ENP Steel	<u>TVO-2M</u>	<u>TVO-3M</u>
#10-32	Plastic	<u>TVO-2MF</u>	<u>TVO-3MF</u>
1/8" NPT	ENP Steel	<u>TVO-2MP</u>	<u>TVO-3MP</u>
1/8" NPT	Plastic	<u>TVO-2MFP</u>	<u>TVO-3MFP</u>

Air Flow: 4.0 scfm @ 50 psig; 6.8 scfm @ 100 psig

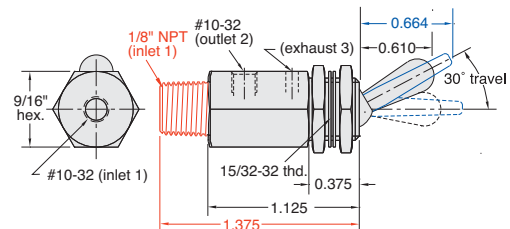

For high temperature applications (up to +400°F), or those that require special seals for chemical compatibility, Clippard offers optional FKM seals.

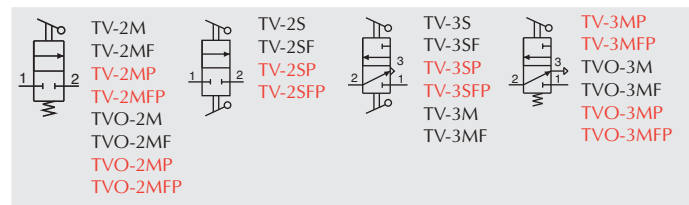

options (suffix)
ENP Plating "ENP" • FKM Seals "V"

MTV 2-Position Toggle Valves

These #10-32 ported 2-way, 3-way, 4-way and 5 ported 4-way valves are manually actuated with a toggle. The toggles are electroless nickel plated steel and have a detent action. The MTV-5 has threaded exhaust and can be connected in a dual inlet pressure configuration.

Medium: Air, Water or Oil

Input Pressure: 150 psig max.

Air Flow: MTV-2: 4.0 scfm @ 50 psig; 7.3 scfm @ 100 psig; MTV-3: 4.0 scfm @ 50 psig; 6.8 scfm @ 100 psig; MTV-4, MTV-5: 6 scfm @ 50 psig, 10 scfm @ 100 psig

Force to Rotate Toggle: MTV-2, MTV-4: 12 oz.; MTV-3, MTV-5: 16 oz. nominal.

Mounting: 15/32-32 thread. Nut and lockwashers furnished.

Materials: Brass body, Nitrile seals, stainless steel stem and spring

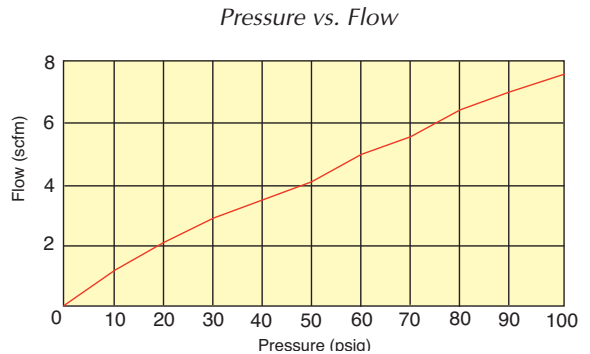

- 2-Way and 3-Way are poppet valves
- 4-Way and 5-Way are spool valves
- 5-Way valves a Fully-Ported or all ports are usable

Normally-Closed Poppet Valves



(MTV-3 shown)

Port(s)	Toggle	2-Way	3-Way
#10-32	ENP Steel	<u>MTV-2</u>	<u>MTV-3</u>
1/8" NPT	ENP Steel	<u>MTV-2P</u>	<u>MTV-3P</u>

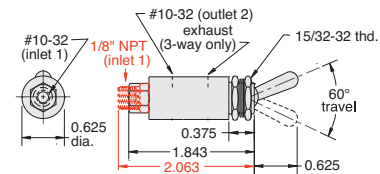

Normally-Open Spool Valves



(MTV-4F shown)

Port(s)	Toggle	Exhaust	4-Way
#10-32	ENP Steel	To Atmosphere	<u>MTV-4</u>
#10-32	Plastic	To Atmosphere	<u>MTV-4F</u>
#10-32	ENP Steel	#10-32	<u>MTV-5</u>
#10-32	Plastic	#10-32	<u>MTV-5F</u>

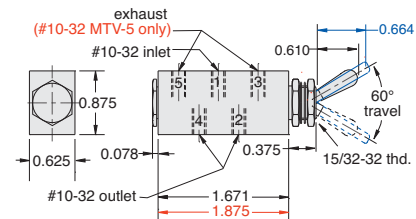

For high temperature applications (up to +400°F), or those that require special seals for chemical compatibility, Clippard offers optional FKM seals.

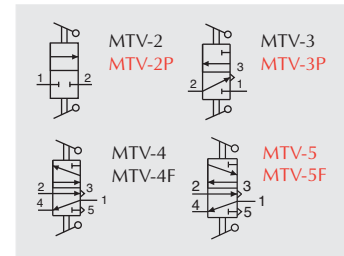

options (suffix)

ENP Plating • ENP • FKM Seals • V

PAV-PAVO Air-Piloted Valves

These Normally-Open or Normally-Closed 2-way and 3-way valves incorporate an integral pilot actuator that provides a compact assembly and simple installation. The internal valving is identical to the MAV-2/3 or MAVO-2/3.

Medium: Air, Water or Oil

Input Pressure: PAV-2/3: 300 psig; PAVO-2/3:150 psig max.

Air Pilot Pressure: 15 psig min.

Air Flow: PAV-2/3: 4.0 scfm @ 50 psig; 6.8 scfm @ 100 psig;
PAVO-2/3: 6.8 scfm @ 50 psig; 11.6 scfm @ 100 psig

Mounting: 5/8-32 thread or #4 screw. Nut and lockwasher may be ordered separately. Part Number: PAV-MH

Materials: Brass body, Nitrile seals, stainless steel stem and spring

Foot Bracket: FB-1791

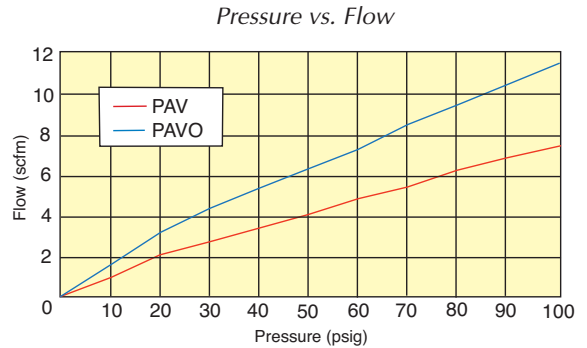

- Air-piloted valves are ideal for remote and miniature applications where you need higher air flow and/or lower power.

options (suffix)
ENP Plating "ENP" • FKM Seals "V"

Normally-Closed Poppet Valves



(PAV-2P shown)

Port(s)	2-Way	3-Way
#10-32	<u>PAV-2</u>	<u>PAV-3</u>
1/8" NPT	<u>PAV-2P</u>	<u>PAV-3P</u>

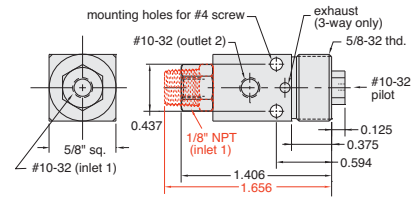

Normally-Open Spool Valves



(PAVO-2 shown)

Port(s)	2-Way	3-Way
#10-32	<u>PAVO-2</u>	<u>PAVO-3</u>
1/8" NPT	<u>PAVO-2P</u>	<u>PAVO-3P</u>

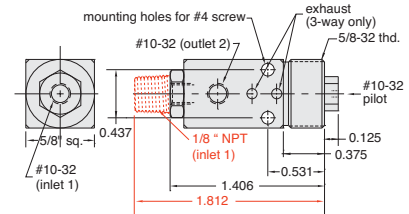

CUSTOMer solutions

If you need a product that fits your application perfectly, Clippard has the capability to design or modify one of its products to suit your exact needs. We understand that a standard catalog product may be close but not be exactly what you need. **Let us know YOUR Need, and we will help to find YOUR Solution!**

Specials!

Clippard has been and still is a pioneer in miniature pneumatics. This cartridge 2-way valve is small and packs a lot of flow into a very tight package. If you don't see what you need in this section, just call us!



MJTV 1/8" NPT Toggle Valves

3-way valves have a supply, outlet and exhaust port. When the toggle is in the "on" position, air flows from the inlet to the outlet and the exhaust port is blocked. Moving the toggle to the "off" position closes the inlet and opens the outlet to an exhaust port which vents the outlet to atmosphere. 4-way and 5-way valves can supply and exhaust two different outlets, and are commonly used with double-acting cylinders. When the toggle is in one position, air flows from the inlet to one of the outlets. The second outlet is open to the exhaust port which is vented to atmosphere. Moving the toggle to the opposite position opens the inlet to the second outlet while exhausting the first outlet. 5 ported 4-way valves can be plumbed in a dual pressure inlet configuration to save air consumption.

Medium: Air

Input Pressure: MJTV-3: 300 psig; MJTV-4/5: 150 psig max.

Force to Rotate Toggle: MJTV-4: 12 oz.; MJTV-3, MJTV-5: 16 oz. nominal

Mounting: 15/32-32 thread. Nuts and lockwashers furnished.

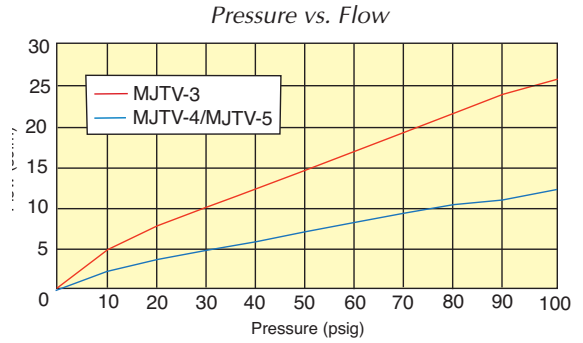

- Compact, rugged construction
- Proven reliability
- Brass body, Nitrile seals, stainless steel stem and spring

Normally-Closed 3-Way 2-Position Poppet Valve



Port(s)	Toggle	3-Way
1/8" NPT	ENP Steel	<u>MJTV-3</u>

Air Flow: 14 scfm @ 50 psig, 25 scfm @ 100 psig;

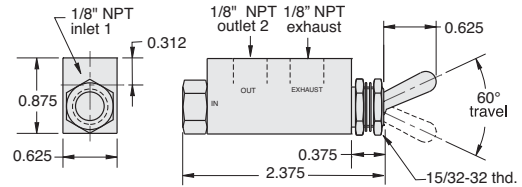

Normally-Open/Normally-Closed 4-Way 2-Position Valves



(MJTV-4 shown)

Port(s)	Toggle	4-Way
1/8" NPT	ENP Steel	<u>MJTV-4</u>
1/8" NPT	Plastic	<u>MJTV-4E</u>

Air Flow: 6.5 scfm @ 50 psig, 10.5 scfm @ 100 psig

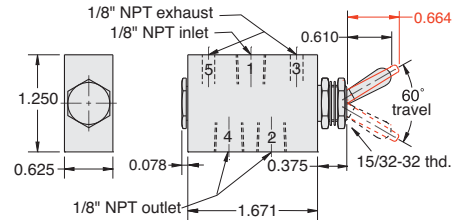

Normally-Open/Normally-Closed 4-Way Fully-Ported Spool Valves



(MJTV-5F shown)

Port(s)	Toggle	4-Way
1/8" NPT	ENP Steel	<u>MJTV-5</u>
1/8" NPT	Plastic	<u>MJTV-5E</u>

Air Flow: 6.5 scfm @ 50 psig, 10.5 scfm @ 100 psig

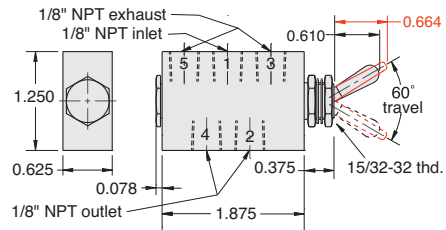

options (suffix)

ENP Plating "-ENP" • FKM Seals "-V"



For high temperature applications (up to +400°F), or those that require special seals for chemical compatibility, Clippard offers optional FKM seals.

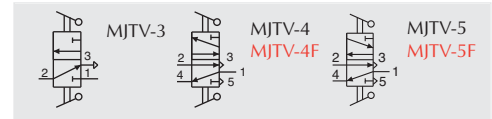

FV Series Spool Valves

These balanced spool valves are "fully ported" which means that all ports are useable and can handle pressure or vacuum or both. The FV-3 is a 3-way but can be used as a 2-way normally open or closed by plugging port 2 or 4. As a 3 way it can be connected as a normally closed, normally open and as a selector or diverter. The FV-5 can be connected in a dual pressure inlet configuration.

Medium: Air, Oil & Water

Input Pressure: 150 psig max.

Stem Travel: 1/8"

Force For Full Stem Travel: FV-3, FV-3P, FV-4, FV-4P, FV-5, FV-5P - 4.5 pounds nominal. FV-3D, FV-3DP, FV-4D, FV-4DP, FV-5D, FV-5DP - 1.5 pounds nominal.

Mounting: 15/32-32 thread. Nuts and lockwashers furnished.

Materials: Brass body, Nitrile seals, stainless steel stem and spring

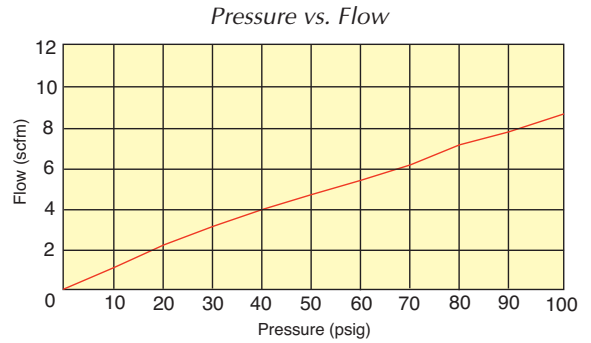

- Designed for use with Clippard manual, air-piloted, electrical or mechanical actuators, or combinations

options (suffix)
ENP Plating "ENP" • FKM Seals "V"

3-Way #10-32 Valves



(FV-3D shown)

Port(s)	Actuation	3-Way
#10-32	Spring Return	FV-3
#10-32	2-Position	FV-3D

Air Flow: 6 scfm @ 50 psig; 10 scfm @ 100 psig

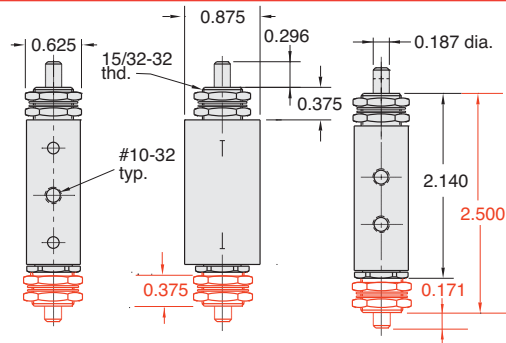

3-Way 1/8" NPT Valves



(FV-3P shown)

Port(s)	Actuation	3-Way
1/8" NPT	Spring Return	FV-3P
1/8" NPT	2-Position	FV-3DP

Air Flow: 6.5 scfm @ 50 psig; 10.5 scfm @ 100 psig

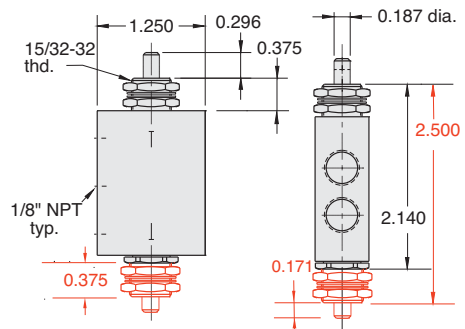

4-Way #10-32 Valves



(FV-4 shown)

Port(s)	Actuation	4-Way
#10-32	Spring Return	FV-4
#10-32	2-Position	FV-4D

Air Flow: 6 scfm @ 50 psig; 10 scfm @ 100 psig

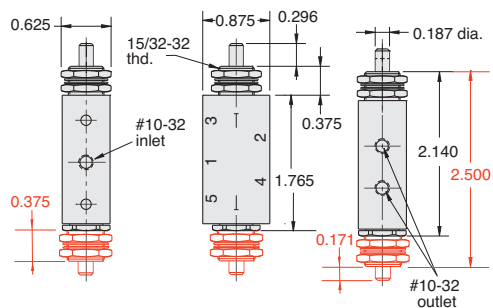

FV Series Spool Valves Cont'd.

4-Way 1/8" NPT Valves



(FV-4DP shown)

Port(s)	Actuation	4-Way
1/8" NPT	Spring Return	FV-4P
1/8" NPT	2-Position	FV-4DP

Air Flow: 6.5 scfm @ 50 psig; 10 scfm @ 100 psig

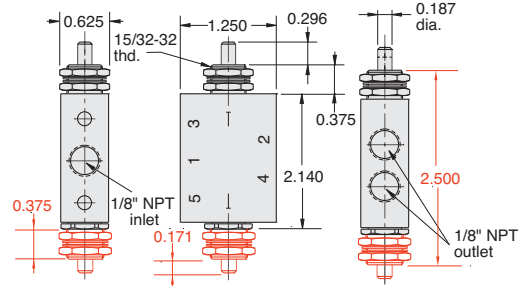

4-Way Fully-Ported #10-32 Valves



(FV-5 shown)

Port(s)	Actuation	4-Way
#10-32	Spring Return	FV-5
#10-32	2-Position	FV-5D

Air Flow: 6 scfm @ 50 psig; 10 scfm @ 100 psig

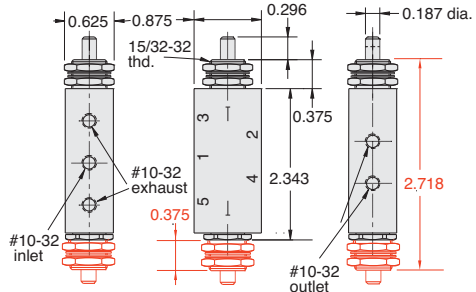

4-Way 1/8" NPT Fully-Ported Valves



(FV-5DP shown)

Port(s)	Actuation	Exhaust	4-Way
1/8" NPT	Spring Return	1/8" NPT	FV-5P
1/8" NPT	2-Position	1/8" NPT	FV-5DP

Air Flow: 6.5 scfm @ 50 psig; 10.5 scfm @ 100 psig

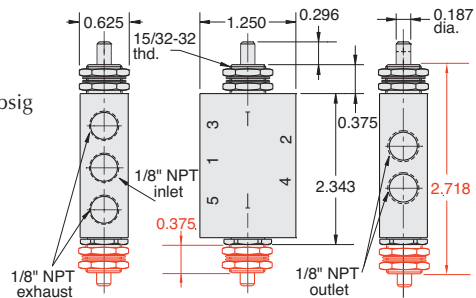

For high temperature applications (up to +400°F), or those that require special seals for chemical compatibility, Clippard offers optional FKM seals.

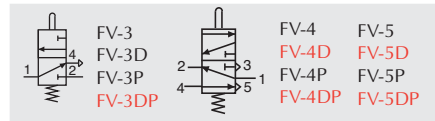

options (suffix)
ENP Plating "ENP" • FKM Seals "-V"

Flow Paths for "FTV & FV" Series Valves

Solid lines indicate flow paths with toggle or stem in one direction. Dotted lines indicate flow paths when the toggle or stem are shifted.

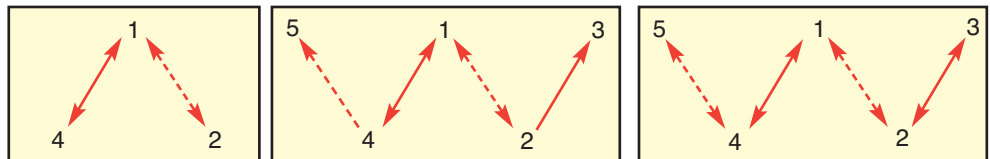

FTV Series Toggle Valves

2-Position, #10-32 & 1/8" NPT Ports

3-way valves have a supply, outlet and exhaust port. When the toggle is in the "on" position air flows from the inlet to the outlet and the exhaust port is blocked. Moving the toggle to the "off" position closes the inlet and opens the outlet to an exhaust port which vents the outlet to atmosphere. 3-way toggle valves may have a poppet or spool and by movement of the toggle may either be 2-position or have a momentary actuation.

Medium: Air

Force to Rotate Toggle: 16 oz. nominal

Mounting: 15/32-32 thread. Nuts and lockwashers furnished.

Materials: Brass body, Nitrile seals, stainless steel stem and spring

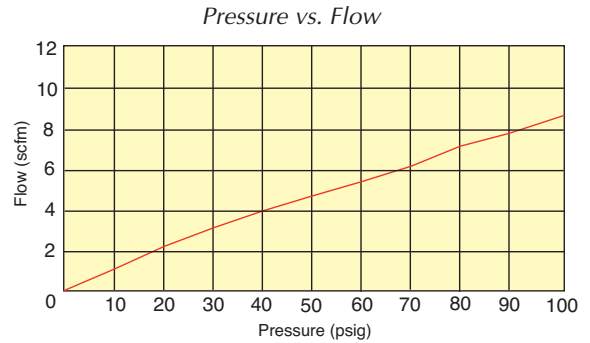

- Compact design
- ENP steel or plastic toggles

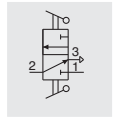

options (suffix)
ENP Plating "-ENP" • FKM Seals "-V"

3-Way #10-32 Valves



(FTV-3 shown)

Port(s)	Toggle	3-Way
#10-32	ENP Steel	<u>FTV-3</u>
#10-32	Plastic	<u>FTV-3E</u>

Air Flow: 6 scfm @ 50 psig; 10 scfm @ 100 psig

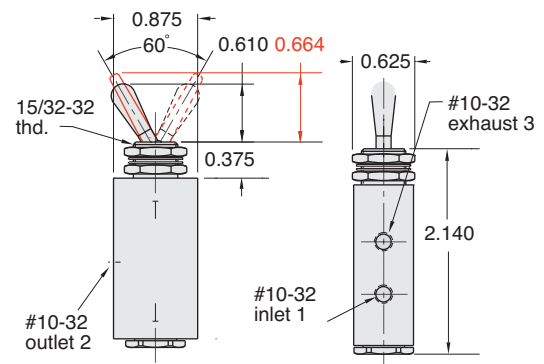

3-Way 1/8" NPT Valves



(FTV-3FP shown)

Port(s)	Toggle	3-Way
1/8" NPT	ENP Steel	<u>FTV-3P</u>
1/8" NPT	Plastic	<u>FTV-3FP</u>

Air Flow: 6.5 scfm @ 50 psig; 10.5 scfm @ 100 psig

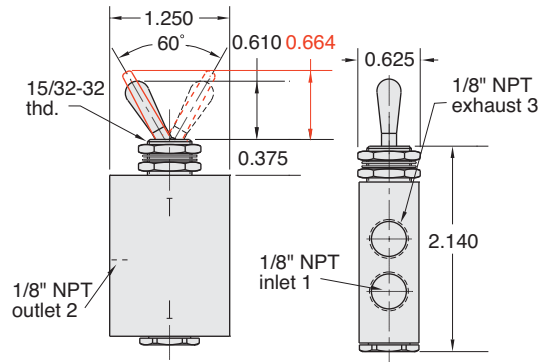

Same-Day Shipping

Huge Inventory, Same-Day Shipping

Hundreds of miniature cylinders, control valves, electronic valves, fittings and other products in stock and ready to ship the same day! Order by 2:30 p.m. EST and items ship the same day. Competitive pricing! Exceptional quality and reliability!

15/32 Panel Mounting Nut

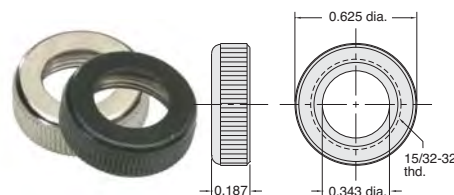

Brass with black or bright nickel finish

Part No.	Finish
<u>11406-1</u>	Black
<u>11406-2</u>	Bright

NEW! HV Series Stem & Toggle Valves

3-Way & 4-Way Styles

The HV-3 Series is a fully-ported 3-way valve. This can be used as a selector valve choosing between two separate pressures or fluids (port 2 or 4) going to a single output (port 1). Being fully-ported, the inverse will work as well using the valve as a diverter sending a fluid (port 1) to two separate outputs (port 2 or 4). Also, the valve may be used as a Normally-Closed or Normally-Open 3-way valve. The HV-4 series is a 4-way valve that vents its exhaust ports to atmosphere and is ideal for powering simple cylinder applications.

Medium: 3-Way: Air, Water or Oil; 4-Way: Air

Input Pressure: 150 psig max.

Air Flow: 6.5 scfm @ 50 psig; 11.8 scfm @ 100 psig

Temperature Range: 32 to 230°F

Force for Full Stem Travel: 4 1/2 lb. nominal

Stem: Stainless Steel; **Toggle:** ENP Steel or Plastic

Mounting (Cartridge Style): Inserts into a 1/2" bore



Ports: #10-32, Cartridge

Stem Travel: 1/8"

Seals: Nitrile, FKM optional

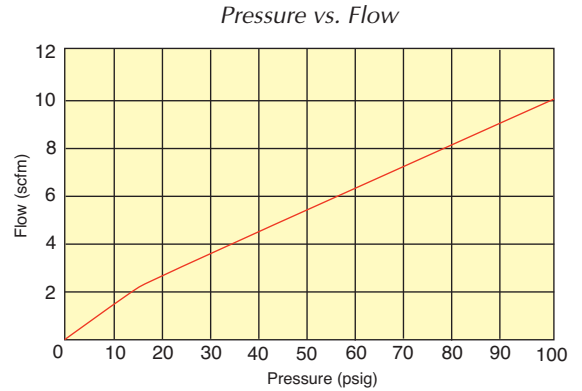

- Small, compact size, lightweight
- Design flexibility and fast response
- 15/32-32 male thread for panel mounting
- HV-3 can be used as a Normally-Open or Closed 3-way valve
- 4-way valves exhaust to atmosphere

3-Way & 4-Way Stem Valves



3-Way	4-Way
HV-3	HV-4

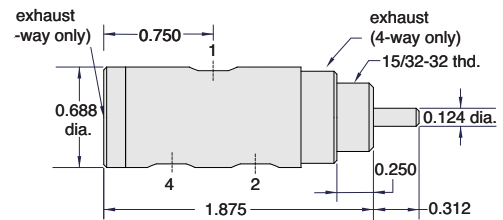

3-Way & 4-Way Toggle Valves



Toggle	3-Way	4-Way
ENP Steel	HTV-3	HTV-4
Plastic	HTV-3E	HTV-4E

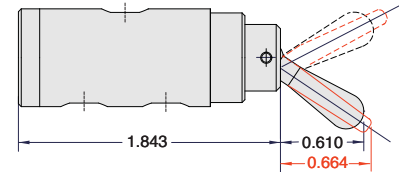

3-Way & 4-Way Stem Cartridge Valves



3-Way	4-Way
HV-3C	HV-4C

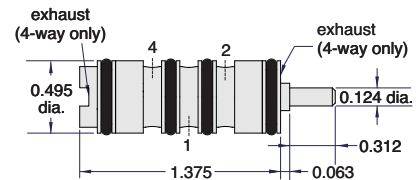

3-Way & 4-Way Toggle Cartridge Valves



Toggle	3-Way	4-Way
ENP Steel	HTV-3C	HTV-4C
Plastic	HTV-3CE	HTV-4CE

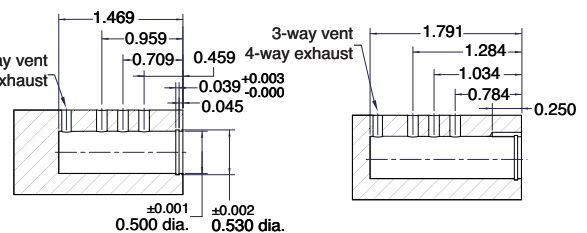
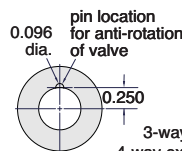
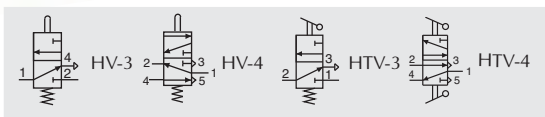
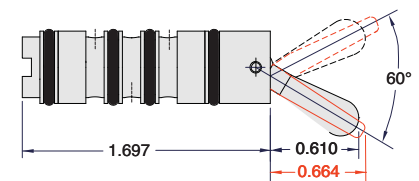

options (suffix)
ENP Plating "-ENP" • FKM Seals "-V"

NEW! GV Series High Flow Poppet Valves

Toggle, Stem & Cartridge Styles

The GV series valves offer 10 times more flow than the MAV series and 2.5 times the flow of the MJV series. With Clippard's versatile 15/32-32 nose thread, a large variety of buttons and valve actuators can be used with the stem operated valves. The GTV series are toggle valves with panel mounting capabilities (5/8-32 nose thread). The outlet port on all GV valves can be easily positioned to any orientation for mounting convenience.

Medium: 2-Way: Air, Water or Oil; 3-Way: Air

Input Pressure: 150 psig max.

Air Flow: 38 scfm @ 50 psig; 67 scfm @ 100 psig

Temperature Range: 32 to 230°F

Ports: 1/4" NPT, 3/8" Push-Quick, Cartridge

Force for Full Stem Travel: 9 lb. nominal @ 100 psig

Mounting (Cartridge Style): Inserts into a 0.687" bore

Stem: Stainless Steel; **Toggle:** ENP Steel; **Stem Travel:** 1/8"



Clippard's New EGV Series valves are an electronically piloted version of the GV cartridge valves, ideal for large flow, low leak applications. See [Page 212](#).

options
Corrosion-Resistant™ CR-™ FKM Seals™-V™



Pressure vs. Flow

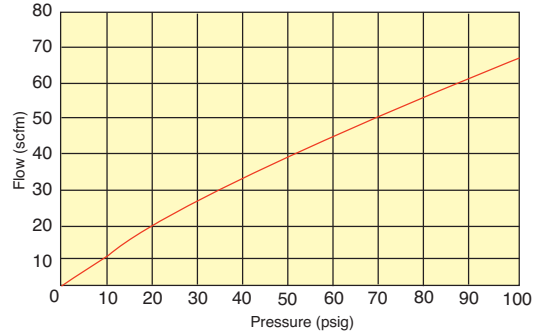

- Will accept a variety of manual, air pilot, electrical or mechanical actuators
- Small, compact size, lightweight
- Design flexibility and fast response
- Corrosion-resistant series also available
- Nitrile seals standard, FKM optional

2-Way & 3-Way Toggle Valves, 1/4" NPT



(GTV-2Q shown)

Inlet	Outlet	2-Way	3-Way
1/4" NPTF	1/4" NPTF	GTV-2	GTV-3
1/4" NPTM	1/4" NPTF	GTV-2Q	GTV-3Q

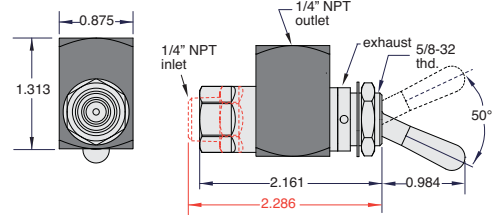

2-Way & 3-Way Toggle Valves, 1/4" NPT, 3/8" Push-Quick Fitting(s)



(GTV-3Q-P12 shown)

Inlet	Outlet	2-Way	3-Way
1/4" NPTM	3/8" PQ	GTV-2Q-P12	GTV-3Q-P12
3/8" PQ	3/8" PQ	GTV-2-P12	GTV-3-P12

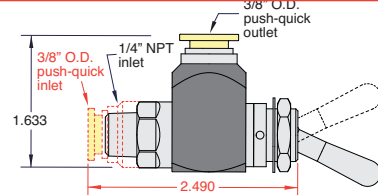

2-Way & 3-Way Stem Valves, 1/4" NPT



(GV-2 shown)

Inlet	Outlet	2-Way	3-Way
1/4" NPTF	1/4" NPTF	GV-2	GV-3
1/4" NPTM	1/4" NPTF	GV-2Q	GV-3Q

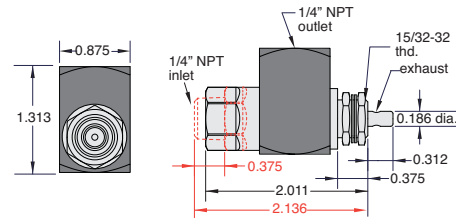

2-Way & 3-Way Stem Valves, 1/4" NPT, 3/8" Push-Quick-Fitting(s)



(GV-3-P12 shown)

Inlet	Outlet	2-Way	3-Way
1/4" NPTM	3/8" PQ	GV-2Q-P12	GV-3Q-P12
3/8" PQ	3/8" PQ	GV-2-P12	GV-3-P12

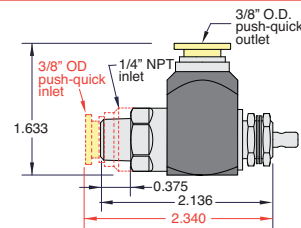

2-Way & 3-Way Stem Cartridge Valves



2-Way	3-Way
GV-2C	GV-3C

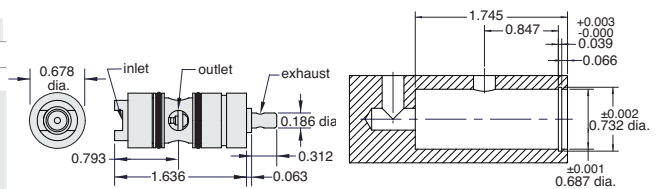
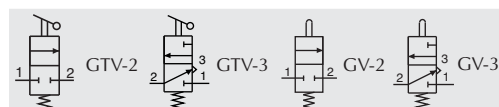

TV Series 4-Way Toggle Valves

4-way 3 position toggle valve with outlet ports open to atmosphere in the center position. The valve can be spring centered, 3 position detent or the "DM" provides a detent on one side and spring return on the other side. The TV-DM model can be used on the momentary side as a "jog" or "manual" control, and with the detented side for "automatic" or "run" mode.

Medium: Air

Input Pressure: 150 psig max.

Materials: Brass body, Nitrile seals, stainless steel spring

Air Flow: 4.5 scfm @ 50 psig; 7.5 scfm @ 100 psig

Force to Rotate Toggle: 8 oz. nominal

Mounting: 5/8-32 thread. Nut and lockwashers furnished.

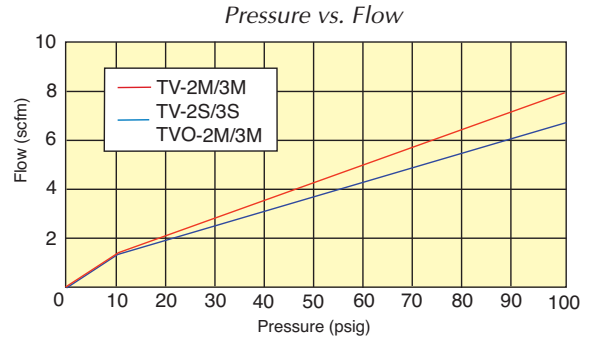

- Designed for use with Clippard manual, air-piloted, electrical or mechanical actuators, or combinations

4-Way #10-32 Valves



(TV-4D shown)

Function	Toggle	4-Way
Detented/Detented	Plastic	TV-4D
Momentary/Momentary	Plastic	TV-4M
Detented/Momentary	Plastic	TV-4DM
Detented/Detented	ENP Steel	TV-4DH
Momentary/Momentary	ENP Steel	TV-4MH
Detented/Momentary	ENP Steel	TV4DMH

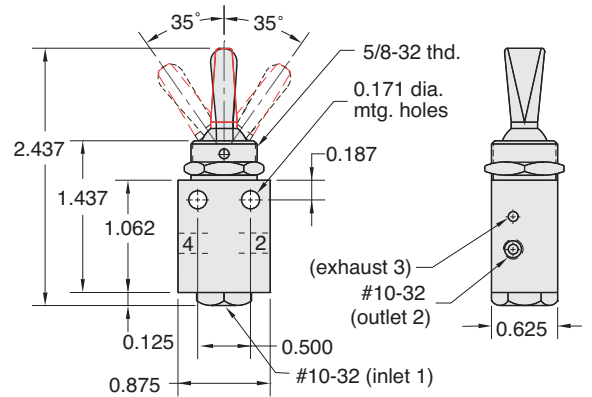

4-Way 1/8" NPT Valves



(TV-4DH shown)

Function	Toggle	4-Way
Detented/Detented	Plastic	TV-4DP
Momentary/Momentary	Plastic	TV-4MP
Detented/Momentary	Plastic	TV-4DMP
Detented/Detented	ENP Steel	TV-4DPH
Momentary/Momentary	ENP Steel	TV-4MPH
Detented/Momentary	ENP Steel	TV4DMPH

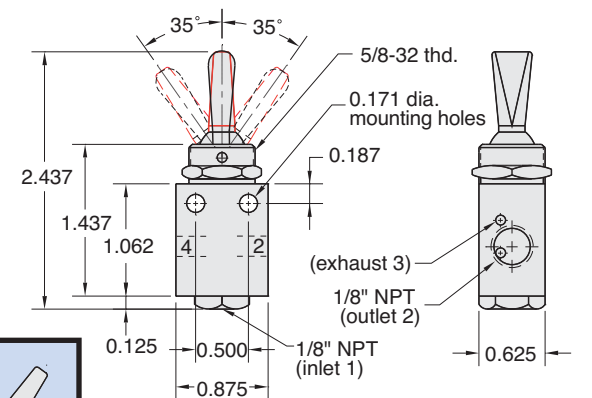

options (suffix)
ENP Plating "ENP" • FKM Seals "V"

Model Number	Porting	Toggle	Center Position	Function
TV-4D	#10-32	Detented	SPRING CENTERED supply blocked both sides exhausted	Detented
TV-4DP	1/8" NPT			Momentary
TV-4M	#10-32	Momentary		Momentary
TV-4MP	1/8" NPT			Momentary
TV-4DM	#10-32	Detented		Momentary
TV-4DMP	1/8" NPT			Momentary

FBV Series Fill & Bleed Valves

The FBV-3 may be used to pressurize or “fill” a chamber or bladder by depressing the toggle in one direction and then de-pressurize or “bleed” that same chamber or bladder by depressing the toggle in the other direction. Toggling back and forth between the inlet and exhaust provides a fine adjustment of the required pressure in the chamber or bladder.

Medium: Air

Input Pressure: 120 psig max.



Materials: Brass body, Nitrile seals, stainless steel stem and spring

Air Flow:

Adjustable

3.0 scfm @ 50 psig
5.0 scfm @ 100 psig

Full-Flow (F)

4.5 scfm @ 50 psig
7.5 scfm @ 100 psig

Toggle: Plastic or ENP Steel

Mounting: 5/8-32 thread. Nut and lockwashers furnished. Two 0.171 mounting holes in body or may be mounted directly on a cylinder.

Force For Full Stem Travel: 8 oz. nominal

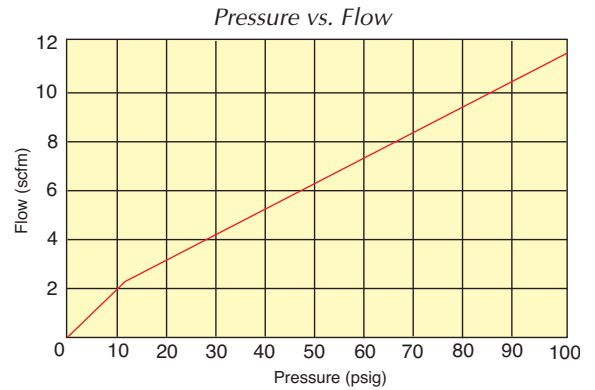

- Adjustable models have built-in needle valves to control flow
- Full flow models may be used as pressure selectors

#10-32 Valves



Full Flow
(Plastic Toggle shown)

Flow	Function	Toggle	Part No.
Adj.	Detented/Detented	Plastic	FBV-3D
Full	Detented/Detented	Plastic	FBV-3DF
Adj.	Momentary/Momentary	Plastic	FBV-3M
Full	Momentary/Momentary	Plastic	FBV-3MF
Adj.	Detented/Momentary	Plastic	FBV-3DM
Full	Detented/Momentary	Plastic	FBV-3DMF
Adj.	Detented/Detented	ENP Steel	FBV-3DH
Full	Detented/Detented	ENP Steel	FBV-3DFH
Adj.	Momentary/Momentary	ENP Steel	FBV-3MH
Full	Momentary/Momentary	ENP Steel	FBV-3MFH
Adj.	Detented/Momentary	ENP Steel	FBV-3DMH
Full	Detented/Momentary	ENP Steel	FBV-3DMFH

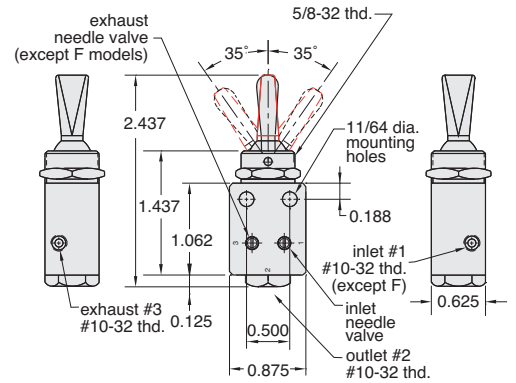

1/8" NPT Valves



Adjustable
(ENP Steel Toggle shown)

Flow	Function	Toggle	Part No.
Adj.	Detented/Detented	Plastic	FBV-3DP
Full	Detented/Detented	Plastic	FBV-3DPF
Adj.	Momentary/Momentary	Plastic	FBV-3MP
Full	Momentary/Momentary	Plastic	FBV-3MPF
Adj.	Detented/Momentary	Plastic	FBV-3DMP
Full	Detented/Momentary	Plastic	FBV-3DMPF
Adj.	Detented/Detented	ENP Steel	FBV-3DPH
Full	Detented/Detented	ENP Steel	FBV-3DPFH
Adj.	Momentary/Momentary	ENP Steel	FBV-3MPH
Full	Momentary/Momentary	ENP Steel	FBV-3MPFH
Adj.	Detented/Momentary	ENP Steel	FBV-3DMPH
Full	Detented/Momentary	ENP Steel	FBV-3DMPFH

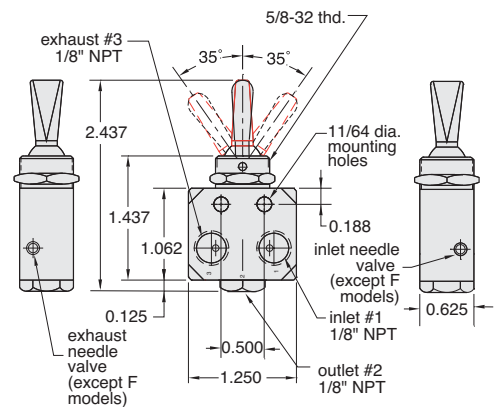

Model Number				
FBV-3D & FBV-3DF FBV-3DP	#10-32 1/8" NPT	Detented	SPRING CENTERED all ports blocked	Detented
FBV-3M & FBV-3MF FBV-3MP	#10-32 1/8" NPT	Momentary		Momentary
FBV-3DM & FBV-3DMF FBV-3DMP	#10-32 1/8" NPT	Detented		Momentary

options (suffix)
ENP Plating "ENP" • FKM Seals "V"

2 Position 2-Way or 3-Way Sleeve Valves

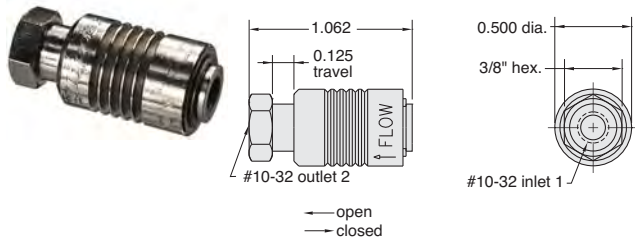

Medium: Air

Stem Travel: 1/8"

Input Pressure: 150 psig

Air Flow: 6.5 scfm @ 50 psig; 11.8 scfm @ 100 psig

Force to Actuate: Approx. 2.5 lbs



Mounting: In-line or direct to fitting

Material: Electroless nickel plated brass

Part No.	Description
<u>SLV-2</u>	2 Position 2-Way Sleeve Valve, #10-32
<u>SLV-3</u>	2 Position 3-Way Sleeve Valve, #10-32



J-Series Sleeve Valves

Features

- Variety of inlet and outlet porting eliminates fittings
- No cross-over between inlet and exhaust ports
- Corrosion resistant electroless nickel plated brass body
- Anodized aluminum sleeve for corrosion resistance
- Smooth operation, low sliding friction
- Nitrile seals; (FKM available)

Clippard J-Series sleeve valves with 1/8" NPT and 1/4" NPT ports offer large flow capability with a relatively short stroke in 2-way and 3-way valves, and no cross-over between inlet and exhaust on the 3-way models.

The JSLV-2 2-way valve and the JSLV-3 3-way valve combine high flow with small size. Unlike ball valves, sleeve valves require no space for a handle. They also provide flexibility in pipe connections and are available with either male or female threads or combinations of both.

The JSLV-2 and JSLV-3 valves feature a smooth opening stroke during which inlet air is directed to the outlet. During the closing stroke, in the opposite direction of travel, the outlet is closed from the inlet and in the JSLV-3 version, the outlet is then exhausted to atmosphere without the inlet ever being connected to exhaust.

Medium: Air, Water or Oil

Force to Actuate: Approx. 8 lbs

Input Pressure: 150 psig/10 bar max.

Mounting: In-line or direct to fitting

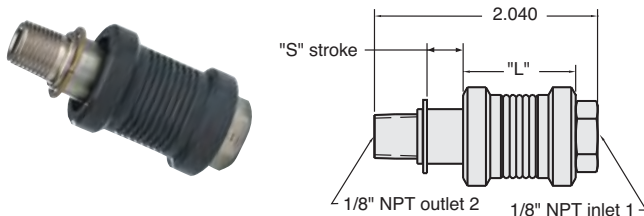

Air Flow: 1/8" NPT: 43 scfm @ 100 psig

Order No.	Type	Inlet	"L"	"S"
<u>JSLV-2-F2M2</u>	2-Way	1/8 Female Pipe	1.155"	0.260"
<u>JSLV-3-F2M2</u>	3-Way	1/8 Female Pipe	1.030"	0.385"

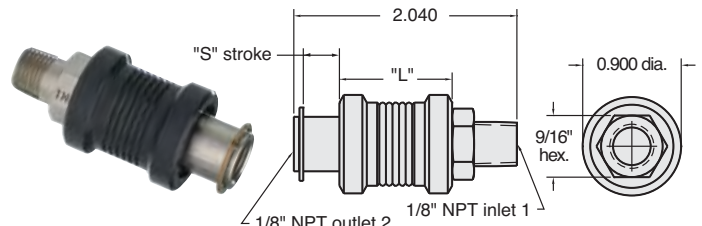

Air Flow: 1/8" NPT: 43 scfm @ 100 psig

Order No.	Type	Inlet	"L"	"S"
<u>JSLV-2-M2F2</u>	2-Way	1/8 Male Pipe	1.155"	0.260"
<u>JSLV-3-M2F2</u>	3-Way	1/8 Male Pipe	1.030"	0.385"

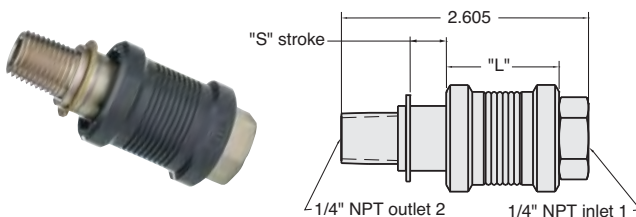

Air Flow: 1/4" NPT: 70 scfm @ 100 psig

Order No.	Type	Inlet	"L"	"S"
<u>JSLV-2-F4M4</u>	2-Way	1/4 Female Pipe	1.325"	0.305"
<u>JSLV-3-F4M4</u>	3-Way	1/4 Female Pipe	1.190"	0.460"

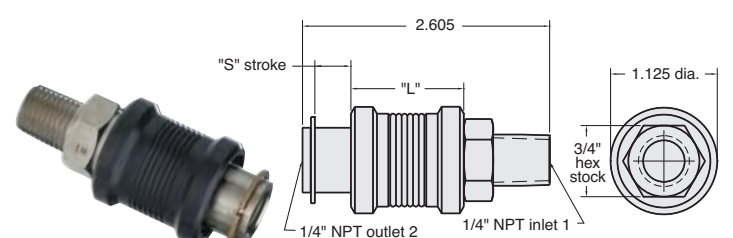

Air Flow: 1/4" NPT: 70 scfm @ 100 psig

Order No.	Type	Inlet	"L"	"S"
<u>JSLV-2-M4F4</u>	2-Way	1/4 Male Pipe	1.325"	0.305"
<u>JSLV-3-M4F4</u>	3-Way	1/4 Male Pipe	1.190"	0.460"

Metric line available. Visit www.clippard.com

Heavy-Duty Limit Valves



These valves feature rugged construction to withstand heavy use. A zinc alloy die cast actuator head with a hardened steel shaft in a bronze bearing is mated to a solid aluminum valve body. Inside is a Clippard series cartridge

valve (MJV-2C or 3C, MJVO-2C or 3C) made of brass and stainless steel with Nitrile seals. Valve cartridge is easily replaced in minutes. Three different style actuator arms are available as shown below.

Part No.	Description
<u>LVA-2</u>	2-Way Poppet Normally-Closed Limit Valve
<u>LVA-3</u>	3-Way Poppet Normally-Closed Limit Valve
<u>LVAO-2</u>	2-Way Normally-Open Limit Valve
<u>LVAO-3</u>	3-Way Normally-Open Limit Valve

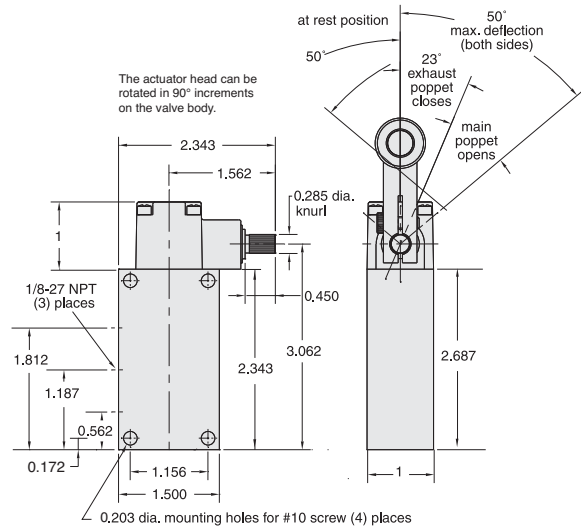

Medium: Air

Stem Travel: Actuator arm may move 50° in either direction

Input Pressure: 300 psig max.

Air Flow: 10 scfm @ 50 psig; 19 scfm @ 100 psig

Torque to Actuate: 3 in./lbs.

Actuation Range: 0 to 23° Off, 23 to 50° On, Maximum travel 50°

Mounting: Four 13/64" dia. mounting holes provided in valve body for use with #10 screw, or for tapping 1/4-20 by customer

Ports: Inlet - 1/8-27" NPT, Outlet - 1/8-27" NPT, Exhaust - 1/8-27" NPT for convenience in porting away exhaust air or attaching muffler; it should not be restricted; exhaust port is not used on 2-ways

Roller Actuator Arms

Roller Actuator Arms are ideal for Clippard heavy-duty air limit valves.

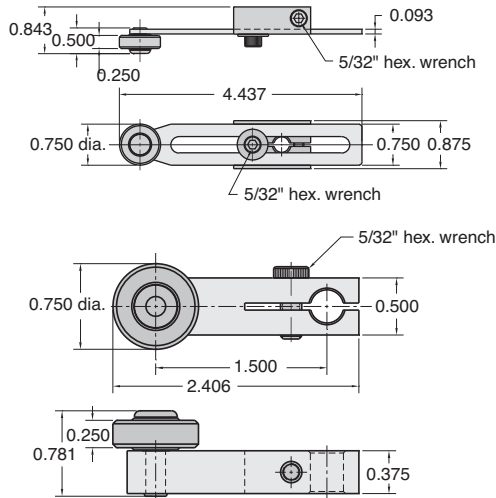

Arm: Aluminum base with steel extendable arm (AR-L only)

Roller: Hardened steel

Adjustment: AR-L only - 1.0" to 3.5"

Mounting: Slotted mounting clamp tightens onto limit valve with 5/32" hex. wrench; may be positioned on limit valve shaft in any direction within a 360° circle.

Part No.	Description
<u>AR-K</u>	Roller Actuator Arm
<u>AR-L</u>	Roller Actuator Arm, Adjustable

Adjustable Rod Actuator Arm

Adjustable Rod Actuator Arm for Clippard heavy-duty air limit valves

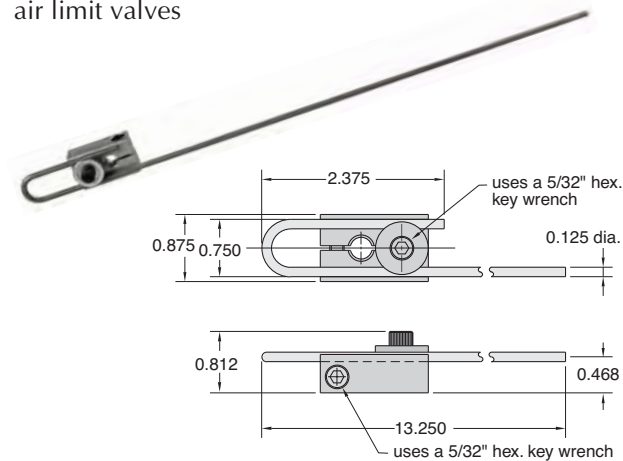

Arm: Steel 1/8" rod 13" long retained by screw clamp; the rod may be shortened and/or bent to desired shape

Mounting: Slotted aluminum mounting clamp may be positioned on limit valve shaft in any direction within a 360° circle

Part No.	Description
<u>AR-M</u>	Rod Actuator Arm

2-Position Spring Return & Air Pilot Valves



Maximatic 3-way air piloted valves are either double pilot or single pilot, spring return in #10-32 thread to 1/2" NPT port sizes. These air piloted valves have 1/8" NPT external pilot ports.

Type: Spool (not bidirectional)

Medium: Air (40 micron filtration) or Inert Gas

Operating Range: Single Air Pilot: 20 to 125 psig; Double Air Pilot: 0 to 125 psig.

Pilot Pressure: See chart

Maximum Pressure: 125 psig

Number of Ports: 3

Materials: Aluminum, Stainless Steel, Thermoplastic

Mounting: Body Ported, Manifold Mount

Temperature Range: 32 to 150°F (0 to 65°C)

Seals: Nitrile



Port	Cv	Flow Rate	
		@ 50 psig	@ 100 psig
#10-32	0.58	16 scfm	27 scfm
1/8" NPT	0.67	18 scfm	31 scfm
1/4" NPT	0.89	26 scfm	49 scfm
3/8" NPT	1.68	51 scfm	93 scfm
1/2" NPT	2.79	91 scfm	171 scfm

Minimum Pilot Pressure

	Single Pilot		Double Pilot	
Operating Pressure (psig)	20	80	20	80
Pilot Pressure (psig)	20	35	5	8

Dim.	MMA-31	MMA-32	MMA-33	MMA-34
DS	0.13	0.17	0.17	0.22
DT	0.13	0.13	0.17	0.17
H	1.07	1.38	1.58	1.97
HS	0.30	0.31	0.41	0.53
L1	2.23	3.06	3.17	3.80
L2	2.71	3.46	3.80	4.72
LB	0.63	0.71	0.94	1.42
LS	0.83	0.98	1.18	2.01
LT	0.75	1.30	1.38	1.73
T	0.71	0.86	1.06	1.34
TO	0.06	0.06	0.16	0.16
TU	0.71	0.65	1.06	1.34

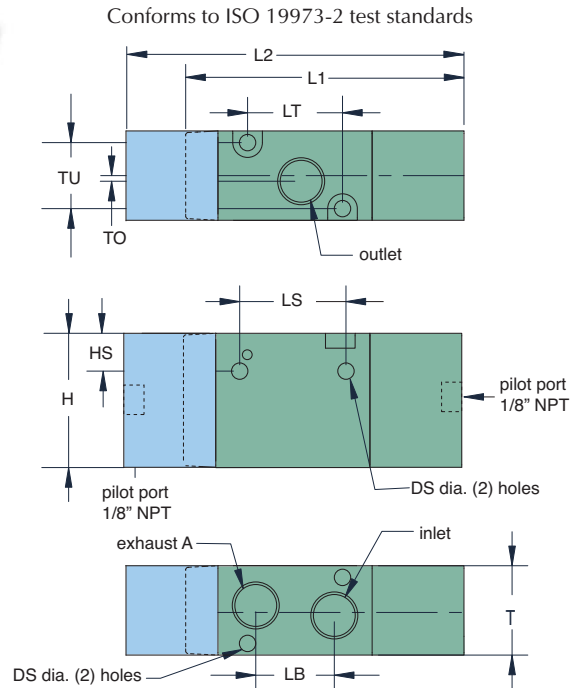

Spring Return Valves		Double Air Pilot Valves		Inlet	Outlet	Exhaust	Cv/scfm*
MMA-31NAS		MMA-31NAA		#10-32	#10-32	#10-32	0.58/27
MMA-31PAS		MMA-31PAA		1/8" NPT	1/8" NPT	1/8" NPT	0.67/31
MMA-32QAS		MMA-32QAA		1/4" NPT	1/4" NPT	1/4" NPT	0.89/49
MMA-33WAS		MMA-33WAA		3/8" NPT	3/8" NPT	3/8" NPT	1.68/93
MMA-34ZAS		MMA-34ZAA		1/2" NPT	1/2" NPT	1/2" NPT	2.79/171

* scfm based on flow @ 100 psig

2-Position Spring Return & Air Pilot Valves



Maximatic® 4-way air piloted valves are either double pilot or single pilot, spring return in #10-32 thread to 1/2" NPT port sizes. These air piloted valves have 1/8" NPT pilot ports.

Type: Spool (not bidirectional)

Medium: Air (40 micron filtration) or Inert Gas

Operating Range: Single Air Pilot: 20 to 125 psig, Double Air Pilot: 0 to 125 psig. Refer to Minimum Pilot Pressure Chart below.

Pilot Pressure: See chart **Maximum Pressure:** 125 psig

Number of Ports: 5 **Mounting:** Body Ported, Manifold

Materials: Aluminum, Stainless Steel, Thermoplastic

Seals: Nitrile

Minimum Pilot Pressure

	Single Pilot	Double Pilot	Three Position
Operating Pressure (psig)	20 80	20 80	20 80
Pilot Pressure (psig)	20 35	5 8	20* 20*

* 30 on MMA-41 Series

Dim.	MMA-41	MMA-42	MMA-43	MMA-44
DS	0.13	0.17	0.17	0.21
DT	0.13	0.13	0.17	0.17
H	1.07	1.38	1.58	1.97
HS	0.16	0.28	0.26	0.29
L1	2.71	3.06	3.76	4.87
L2	3.16	3.62	4.37	5.43
LE	1.09	1.42	1.77	2.48
LO	0.63	0.83	0.96	1.42
LS	0.63	0.79	0.95	1.11
LT	1.18	1.50	1.97	2.82
T	0.71	0.87	1.06	1.34
TO	0.11	0.12	0.16	0.19
TU	0.50	0.67	0.80	1.07

Port	Cv	Flow Rate	
		@ 50 psig	@ 100 psig
#10-32	0.58	16 scfm	27 scfm
1/8" NPT	0.67	18 scfm	31 scfm
1/4" NPT	0.89	26 scfm	49 scfm
3/8" NPT	1.68	51 scfm	93 scfm
1/2" NPT	2.79	91 scfm	171 scfm

Conforms to ISO 19973-2 test standards

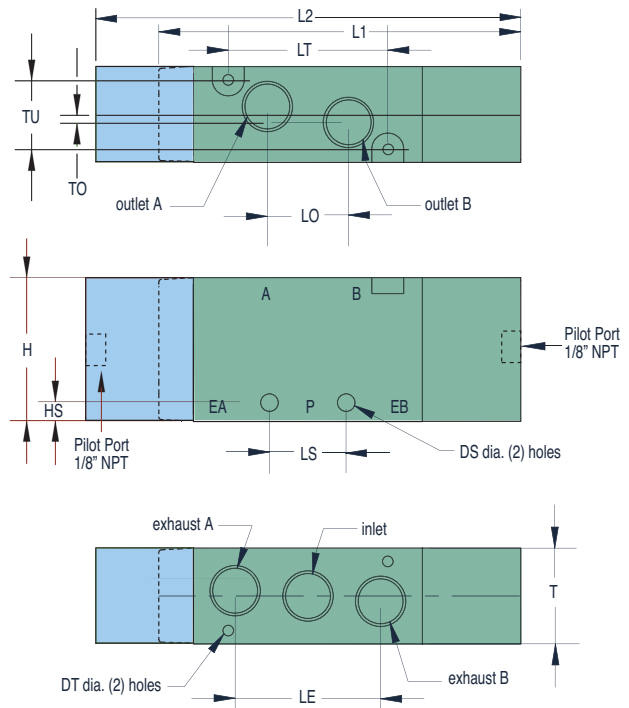

Spring Return Valves		Double Air Pilot Valves		Inlet	Outlet	Exhaust	Cv/scfm*
MMA-41NAS		MMA-41NAA		#10-32	#10-32	#10-32	0.58/27
MMA-41PAS		MMA-41PAA		1/8" NPT	1/8" NPT	1/8" NPT	0.67/31
MMA-42QAS		MMA-42QAA		1/4" NPT	1/4" NPT	1/8" NPT	0.89/49
MMA-43WAS		MMA-43WAA		3/8" NPT	3/8" NPT	1/4" NPT	1.68/93
MMA-44ZAS		MMA-44ZAA		1/2" NPT	1/2" NPT	1/2" NPT	2.79/171

* scfm based on flow @ 100 psig

3-Position Spring Centered Double Air Pilot Valves Closed Center, Pressure Center & Exhaust Center



MMA-44ZAAC

MAXIMUM
Value. *Performance.*

Maximatic® 4-way 3-position double air pilot valves with closed center, pressure center or exhaust center spools are available in #10-32 thread to 1/2" NPT port sizes. These air piloted valves have 1/8" NPT external pilot ports.

Type: Spool (not bidirectional)

Operating Range: 0 to 125 psig

Pilot Pressure: See previous page

Number of Ports: 5

Mounting: Body Ported, Manifold Mount

Dim.	MMA-41	MMA-42	MMA-43	MMA-44
DS	0.13	0.17	0.17	0.21
DT	0.13	0.13	0.17	0.17
H	1.07	1.38	1.58	1.97
HS	0.16	0.28	0.26	0.29
L	3.78	4.37	5.13	5.43
LE	1.09	1.42	1.77	2.48
LO	0.63	0.74	0.96	1.42
LS	0.56	0.98	0.95	1.11
LT	1.18	1.40	1.97	2.82
T	0.71	0.86	1.06	1.34
TO	0.11	0.13	0.16	0.19
TU	0.50	0.65	0.80	1.07

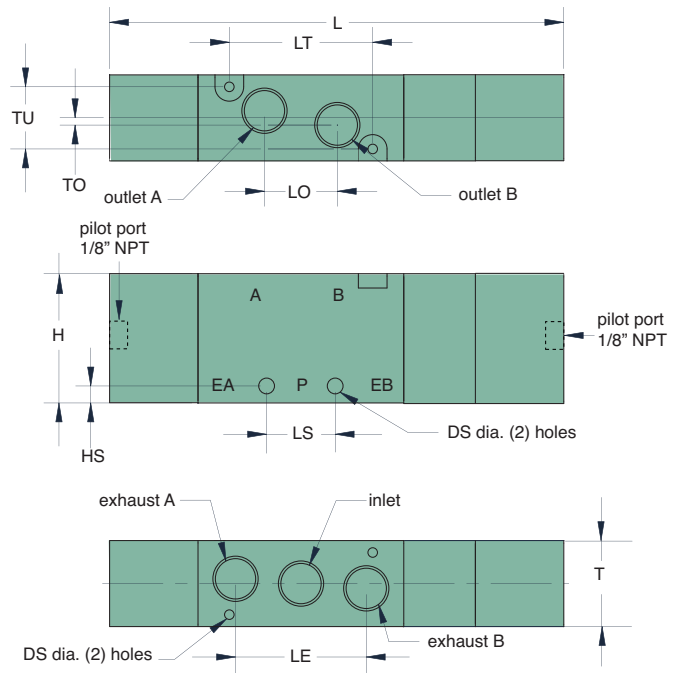

Exhaust Mufflers

For quiet system operation, see pages 154 and 326 for standard and speed control mufflers.



Closed Center	Pressure Center	Exhaust Center	Inlet	Outlet	Exhaust	Cv/scfm*
<u>MMA-41NAAC</u>	<u>MMA-41NAAP</u>	<u>MMA-41NAAE</u>	#10-32	#10-32	#10-32	0.50/23
<u>MMA-41PAAC</u>	<u>MMA-41PAAP</u>	<u>MMA-41PAAE</u>	1/8" NPT	1/8" NPT	1/8" NPT	0.50/23
<u>MMA-42QAAC</u>	<u>MMA-42QAAP</u>	<u>MMA-42QAAE</u>	1/4" NPT	1/4" NPT	1/8" NPT	0.89/49
<u>MMA-43WAAC</u>	<u>MMA-43WAAP</u>	<u>MMA-43WAAE</u>	3/8" NPT	3/8" NPT	1/4" NPT	1.00/72
<u>MMA-44ZAAC</u>	<u>MMA-44ZAAP</u>	<u>MMA-44ZAAE</u>	1/2" NPT	1/2" NPT	1/2" NPT	1.68/93

* scfm based on flow @ 100 psig

Parallel Bar Manifolds

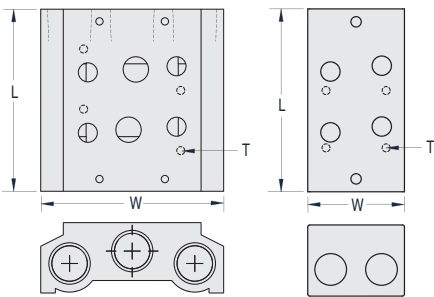

4-Way Manifold

3-Way Manifold



Valve Series	2-Station	4-Station	"L" Dimension 6-Station	8-Station	16-Station	"T" Mtg. Thread
MMA-31/41	2.24	3.73	5.25	6.75	12.69	M4
MMA-32/42	2.71	4.50	6.33	8.13	15.38	M4
MMA-33/43	3.22	5.42	7.62	9.82	18.63	M5
MMA-34/44	3.85	6.56	9.38	12.10	23.11	M5

Parallel circuit manifold bars are available for all sizes of MMA 3- and 4-way valves. **Manifolds are made in increments of two stations from two to 16**, and are supplied with mounting screws and gaskets. Spare kits are also available which include two screws and a gasket. Blank plate supplied with one gasket, two screws and metal plate.

Valve Series	Manifold Inlet/ Exhaust	Blank Plate	2-Station	4-Station	6-Station	8-Station	16-Station
3-Way Valve Manifolds							
MMA-31	1/8"	MMM-31-B	MMM-31-02	MMM-31-04	MMM-31-06	MMM-31-08	MMM-31-16
MMA-32	1/4"	MMM-32-B	MMM-32-02	MMM-32-04	MMM-32-06	MMM-32-08	MMM-32-16
MMA-33	3/8"	MMM-33-B	MMM-33-02	MMM-33-04	MMM-33-06	MMM-33-08	MMM-33-16
MMA-34	1/2"	MMM-34-B	MMM-34-02	MMM-34-04	MMM-34-06	MMM-34-08	MMM-34-16

3-Way Spare Mounting Kit Hardware

27041-31	Hardware Kit for MMA-31 Series Valves	27041-33	Hardware Kit for MMA-33 Series Valves
27041-32	Hardware Kit for MMA-32 Series Valves	27041-34	Hardware Kit for MMA-34 Series Valves

Valve Series	Manifold Inlet/ Exhaust	Blank Plate	2-Station	4-Station	6-Station	8-Station	16-Station
4-Way Valve Manifolds							
MMA-41	1/4"	MMM-41-B	MMM-41-02	MMM-41-04	MMM-41-06	MMM-41-08	MMM-41-16
MMA-42	1/4"	MMM-42-B	MMM-42-02	MMM-42-04	MMM-42-06	MMM-42-08	MMM-42-16
MMA-43	3/8"	MMM-43-B	MMM-43-02	MMM-43-04	MMM-43-06	MMM-43-08	MMM-43-16
MMA-44	1/2"	MMM-44-B	MMM-44-02	MMM-44-04	MMM-44-06	MMM-44-08	MMM-44-16

4-Way Spare Mounting Kit Hardware

27041-41	Hardware Kit for MMA-41 Series Valves	27041-43	Hardware Kit for MMA-43 Series Valves
27041-42	Hardware Kit for MMA-42 Series Valves	27041-44	Hardware Kit for MMA-44 Series Valves

Rebuild Kits

Convenient rebuild kits are available which contain common maintenance items that may be needed during the life of the valve. Each contains a spool, diamond seal, two pilot seals, two pistons with seals, and spring. Consult factory for 3-position kits.

Part No.

27040-31	3-Way Kit, MMA-31
27040-32	3-Way Kit, MMA-32
27040-33	3-Way Kit, MMA-33
27040-34	3-Way Kit, MMA-34
27040-41	4-Way 2 Pos. Kit, MMA-41
27040-42	4-Way 2 Pos. Kit, MMA-42
27040-43	4-Way 2 Pos. Kit, MMA-43
27040-44	4-Way 2 Pos. Kit, MMA-44

3-Way Poppet Palm Button Valves



3-way poppet (MAV-3C) Normally-Closed - bubble tight poppet cartridge valve (- replaceable cartridge)

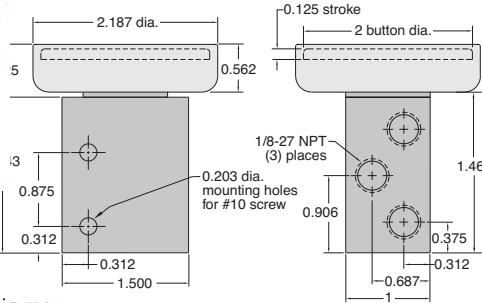

Medium: Air

Stem Travel: 1/8"

Input Pressure: 100 psig max.

Air Flow: 3.5 scfm @ 150 psig; 6.0 scfm @ 100 psig

Force to Actuate: 1.75 lb. manual

Ports: 1/8" NPT - exhaust may be muffled or piped away but NOT restricted

Mounting: Mounting holes provided; optional Bracket Kit #12959 provides additional mounting versatility; valve available with anodized color buttons

Part No.	Description
PB-1-RD	3-Way Poppet Poppet Valve, Red
PB-1-GN	3-Way Poppet Poppet Valve, Green
PB-1-BK	3-Way Poppet Poppet Valve, Black
12959	90° Mounting Bracket Kit (shown below)

Low Force 3-Way Palm Button Valves



3-way low force poppet valve; Normally-Closed; depressing button blocks the sensing port causing rapid valve opening

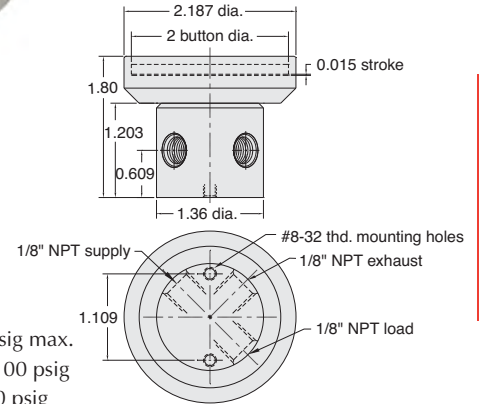

Medium: Air

Input Pressure: 100 psig max.

Air Flow: 22 scfm @ 100 psig

Bleed: 0.1 scfm @ 100 psig

Force to Actuate: 1 oz. manual

Mounting: Mounting holes provided; optional Bracket Kit #2010-50 provides additional mounting versatility; valve available with anodized color buttons

Part No.	Description
PB-2-RD	Low Force 3-Way Poppet Valve, Red
PB-2-GN	Low Force 3-Way Poppet Valve, Green
PB-2-BK	Low Force 3-Way Poppet Valve, Black
2010-050	Mounting Bracket Kit (shown below)

90° Mounting Bracket



90° angle, heavy-duty versatile Mounting Bracket for Clippard palm button valves

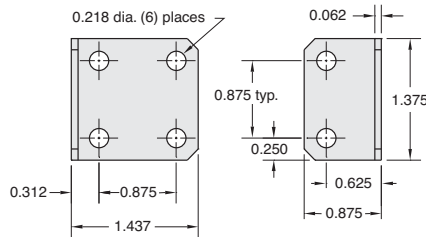

Mounting: Six 7/32" dia. holes on 1/8" centers for attaching valves to bracket
Construction: Stamped from 1/8" thick steel, zinc plated

Part No.	Description
12959	90° Mounting Bracket Kit

Mounting Bracket



Bracket to mount 2010, 2011-1, 2012 and 2013 valves

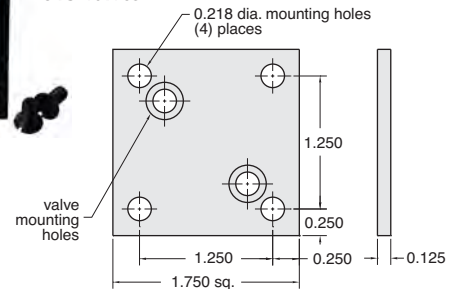

Black anodized finish, two mounting screws furnished

Part No.	Description
2010-050	Mounting Bracket Kit

Push/Pull Valves



Push/Pull spool valves are available in both 3-way and 4-way configurations. The Detent version maintains spool position by friction, while the Momentary spring returns to the home position.

Operating Pressure: 0 to 115 psig

Cv: 0.89

Ports: 1/4" NPT, 1/8" NPT exhaust

Operating Temperature: 32 to 140°F

Mounting: Panel or base mount

Part No.	Description
MMV-P3QD	3-Way, 3 Port Detented Push/Pull Valve
MMV-P4QD	4-Way, 5 Port Detented Push/Pull Valve
MMV-P4QM	4-Way, 5 Port Momentary Push/Pull Valve

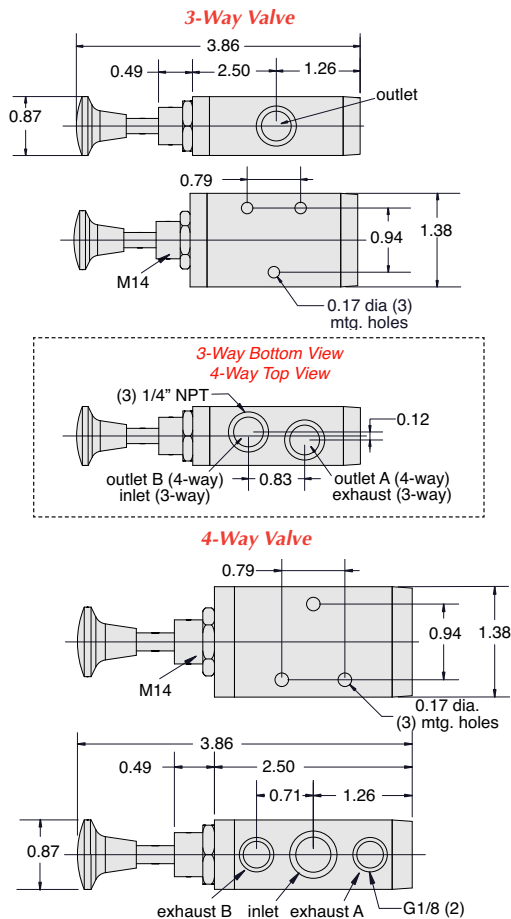

Lever Valves

Lever valves are 3-way or 4-way spool valves with 1/4" NPT ports. They have either a Detented or Momentary manual operation.

Operating Pressure: 0 to 150 psig

Cv: Detented: 1.0
Momentary: 0.89

Port Size: 1/4" NPT

Operating Temperature: 32 to 140°F

Mounting: Panel or base mount



Part No.	Description
MMV-L3QD	3-Way, 2-Position Detented Valve
MMV-L3QM	3-Way, 2-Position Momentary Valve
MMV-L4QD	4-Way, 2-Position Detented Valve
MMV-L4QM	4-Way, 2-Position Momentary Valve
MMV-L4QD-C	4-Way, 3-Position Detented Valve, Closed Center

Other configurations available. Consult factory.

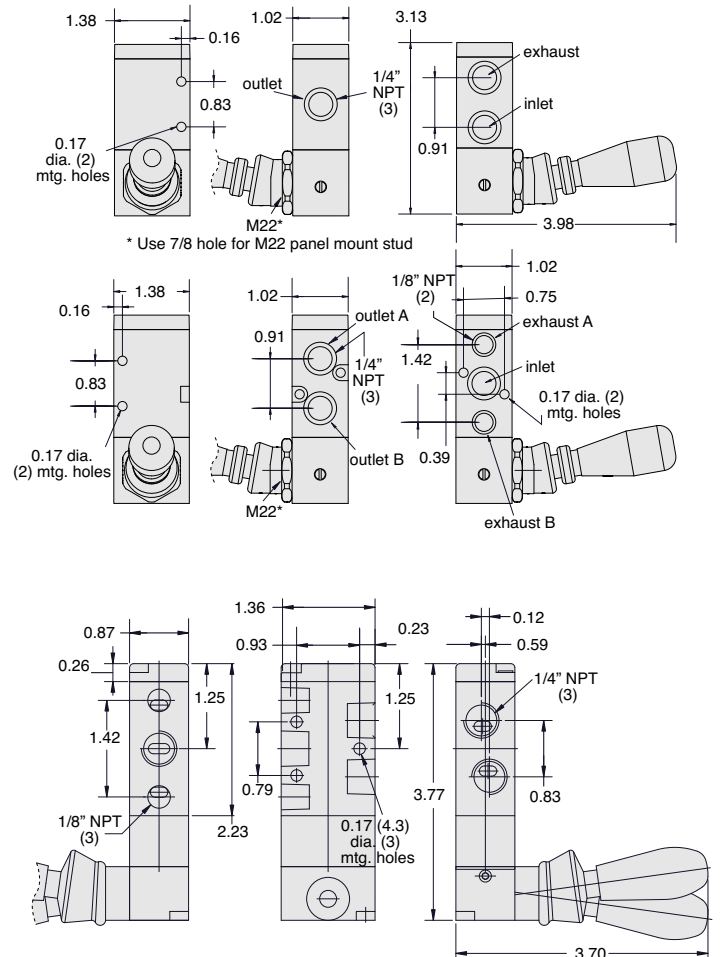

Rotary Valves



Rotary Valves are 4-way valves with 1/4" NPT ports. They are manually-operated 3-position closed center valves.

Operating Pressure: 0 to 150 psig

Ports: 1/4" NPT

Cv: 1.68

Mounting: Base mount

Operating Temperature: 32 to 140°F

Part No.	Description
MMV-R4QN-C	4-Way, 3-Position Non-Detented Rotary Valve
MMV-R4QD-C	4-Way, 3-Position Detented Rotary Valve

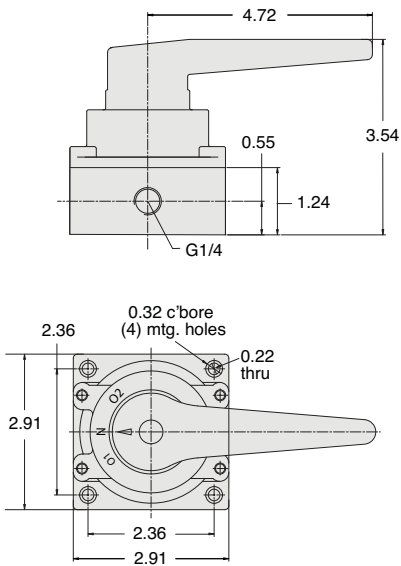

Foot Pedal Valves

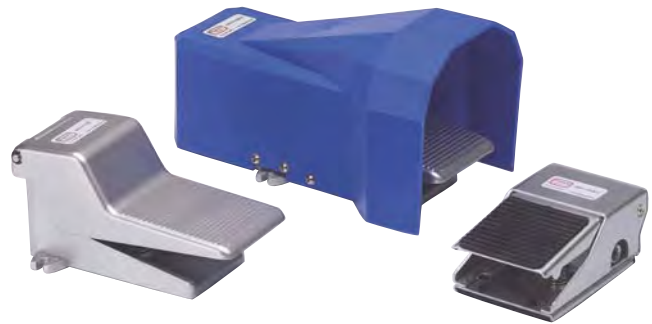

Foot Pedal Valves are 3-way or 4-way valves with 1/4" NPT ports. Two versions are offered; either a low-profile flat pedal or standard pedal with or without guard.

Operating Pressure: 0 to 150 psig

Cv: 1.4

Ports: 1/4" NPT

Mounting: Base mount

Operating Temperature: 32 to 140°F

Part No.	Description
MMV-F3QM-F	3-Way Valve with Flat Pedal
MMV-F4QM-F	4-Way Valve with Flat Pedal
MMV-F4QM	4-Way Valve with Standard Pedal
MMV-F4QM-G	4-Way Valve with Plastic Foot Guard

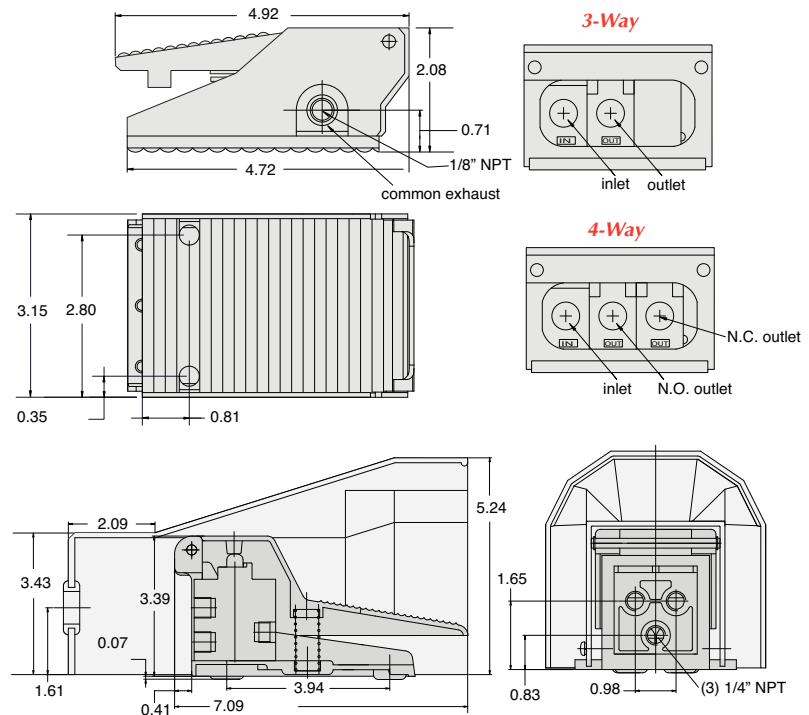

The following valve actuators are compatible with all Clippard MAV, MAVO, MJV, MJVO, ES-1, & FV series valves.

One of the most versatile items in the Clippard line. Permits wide circuit flexibility and allows many control functions to be accomplished pneumatically with less cost, hazards and complexity. Threads onto the tops of our Miniature 2-way, 3-way, and 4-way valves and ES-1 electric switch to provide fast pilot actuation from a pneumatic signal.

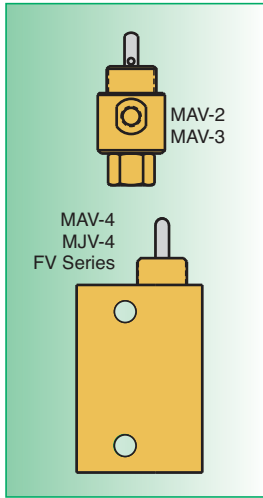

MPA Actuators Can:

- Remotely actuate any number of valves and switches simultaneously in different strategic locations from a single miniature 3-way valve
- Make an ES-1 into a pressure switch
- Act as an air relay, i.e., one pressure source to another.
- Operate the MAV-4D from a single impulse.
- Serve as a pressure interlock or safety device, i.e., turn off power when pressure fails, etc.
- Provide an electric take off from a pneumatic source to start and stop power, actuate electric counters, indicator lights on panel boards, etc.

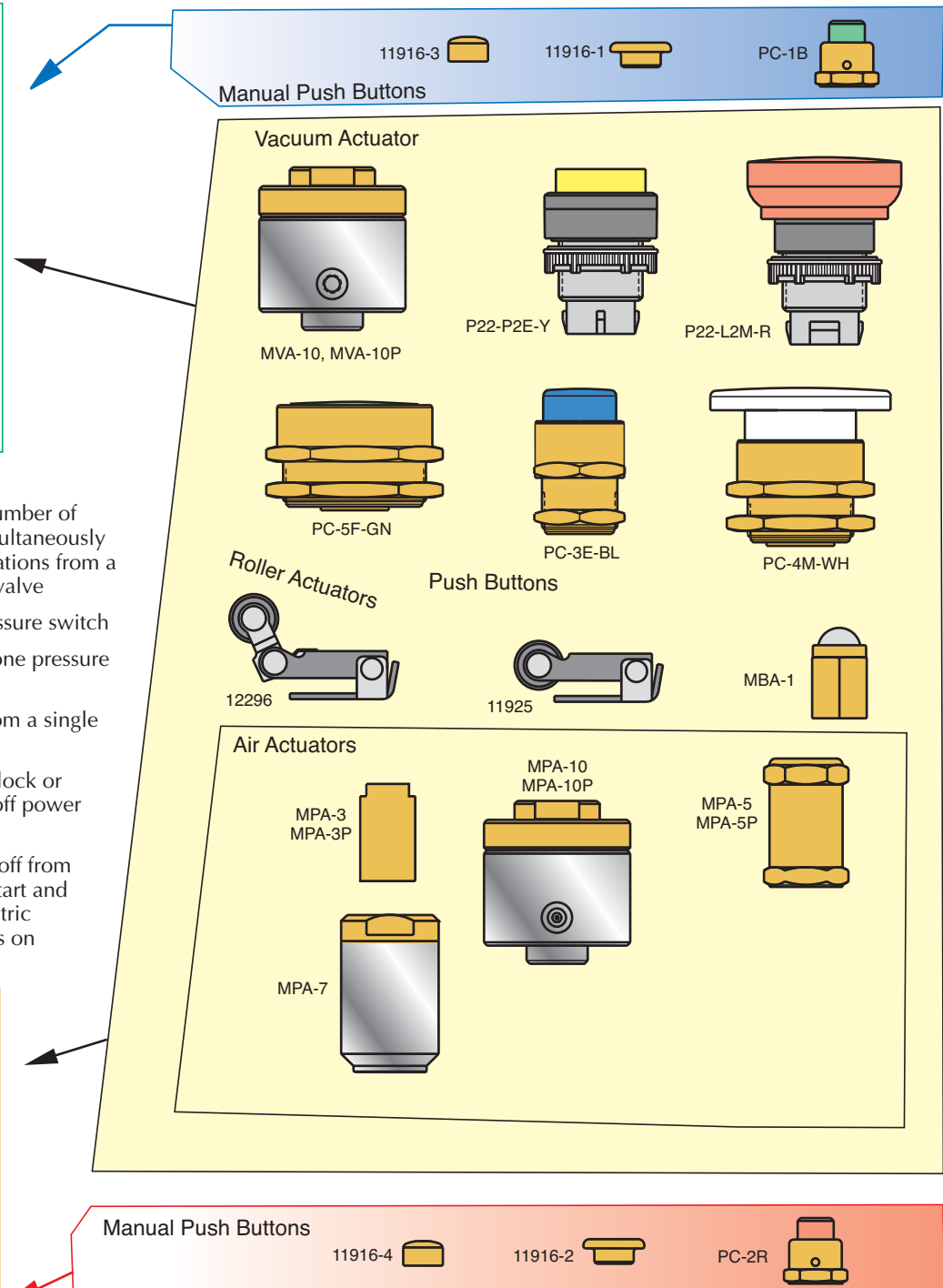
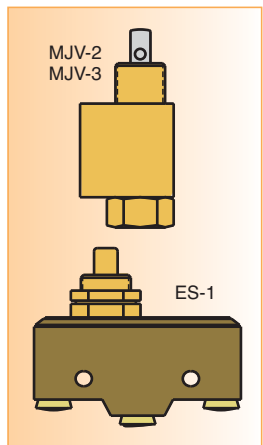

Ball Cam Actuator



Ball Cam Actuator permits the valves and electrical switch to be operated by mechanical movement depressing the ball from any direction.

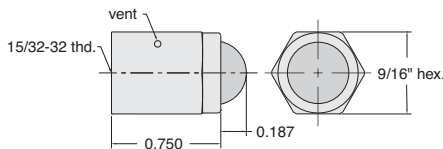

Construction: Body - brass
Ball - stainless steel retained in housing

Operation: Will actuate valve while depressed from any (360°) direction

Mounting: #15/32-32 female to mount to Clippard miniature valves and electric switch

Part No.	Description
<u>MBA-1</u>	Ball Cam Actuator

Roller Cam Actuator

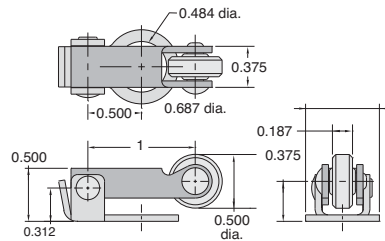

Construction: Stainless steel with nylon roller

Temperature Range: 32 to 230°F

Mounting: 31/64" dia. mounting hole fits #15/32-32 threaded mounting section of valve bodies

Operation: Mounts to valve body, actuates valve when mechanically depressed; valve spring provides return

Part No.	Description
<u>11925</u>	Roller Cam Follower Actuator

Double-Pivoted Actuator

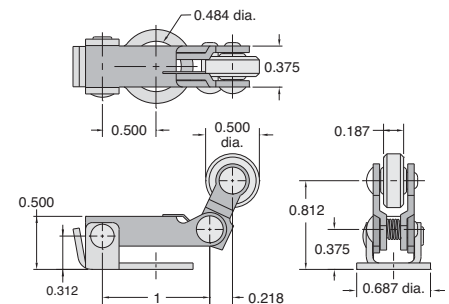

Construction: Stainless steel with nylon roller

Mounting: 31/64" dia. mounting hole fits #15/32-32 threaded mounting section of valve bodies

Operation: Mounts to valve body, actuates valve when depressed by activating cam or linear travel device in one direction only; no actuation on return travel

Part No.	Description
<u>12296</u>	Roller, Double-Pivoted 1-Way Cam Follower Actuator

Note for MBA-1, 11925 & 12296:

When mounting on a valve, a space should be provided between the body and the actuator according to the chart to the right:

Valve Mtg. Thd.	MBA-1	11925	12296
0.250 thd. length	0.125"	0.062"	0.062"
0.373 thd. length	0.218"	0.188"	0.188"

A mounting nut (supplied with valve), mounting bracket or washers should be used to obtain the required spacing.

CUSTOMer solutions



A valve used in dental applications features ports located straight out of the back for ease-of-assembly in a tight space. It also incorporates a special toggle to match the customers' aesthetic requirements.

Use any combination of Clippard's electronic valves to actuate any Clippard control valve with an external supply.



In system subassemblies, manifold-mounted components are desirable for an integrator. In this design, Clippard utilizes the miniature regulator series and an air-piloted 2-way valve mounted on a manifold adjacent to our electronic valve.



For more information, visit www.clippard.com/customsolutions

MINIMUM PRESSURE REQUIRED (psig)*													
Clippard Valve	Pressure (psig)					Vacuum (" Hg)	Clippard Valve	Pressure (psig)					Vacuum (" Hg)
	w/MPA3	w/MPA-5	w/MPA-7	w/MPA-10	w/MVA-10			w/MPA3	w/MPA-5	w/MPA-7	w/MPA-10	w/MVA-10	
ES-1 Switch	12	4	2	n/a	n/a		FV-3	41	15	7.5	4.0	8.2	
MAV-2	23	8	4	2.0	4.2		FV-3P	41	15	7.5	4.0	8.2	
MAV-3	23	8	4	2.0	4.2		FV-4	41	15	7.5	4.0	8.2	
MAV-4	36	11	5.5	3.5	7.2		FV-4P	41	15	7.5	4.0	8.2	
MJV-4	36	11	5.5	3.5	7.2		FV-5	41	15	7.5	4.0	8.2	
MAV-4D	13	4	1.5	1.0	2.0		FV-5P	41	15	7.5	4.0	8.2	
MJV-4D	13	4	1.5	1.0	2.0		FV-3D	14	5	2.5	1.5	3.2	
MJV-2	30	10	5	3.0	6.2		FV-3DP	14	5	2.5	1.5	3.2	
MJV-3	30	10	5	3.0	6.2		FV-4D	14	5	2.5	1.5	3.2	
MAVO-2	27	9	4.5	2.5	5.2		FV-4DP	14	5	2.5	1.5	3.2	
MAVO-3	27	9	4.5	2.5	5.2		FV-5D	14	5	2.5	1.5	3.2	
MJVO-2	30	10	5	3.0	6.2		FV-5DP	14	5	2.5	1.5	3.2	
MJVO-3	30	10	5	3.0	6.2		GV-2/3	87	31	16	8.0	16.0	
HV-3/4	41	15	7.5	4.0	8.2								

*with 100 psig to valve inlet

Single Acting Air Pilot Actuators

Input Pressure: 250 psig max.

Construction: Body - brass; Springs - stainless steel; Seals - Nitrile; Piston - Delrin®



Mounting: #15/32-32 female thread to mount to Clippard miniature valves and components

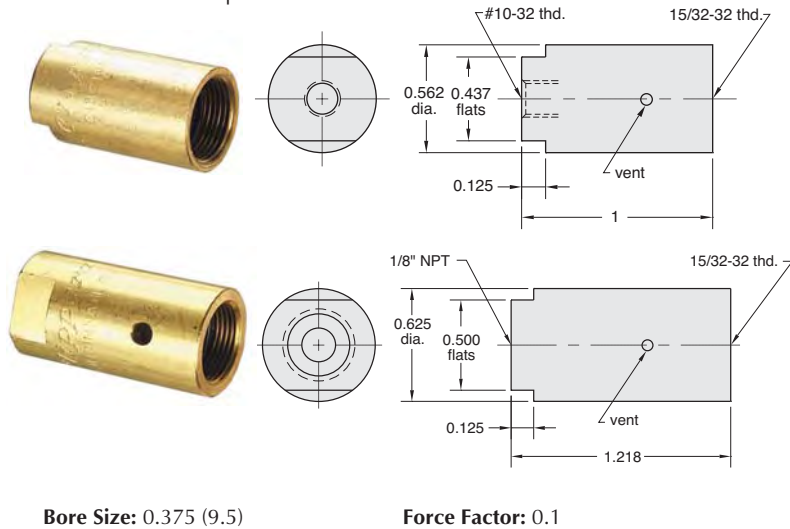

Bore Size: 0.375 (9.5)

Force Factor: 0.1

Part No.	Description
MPA-3	Single Acting, Spring Return Actuator, #10-32
MPA-3P	Single Acting, Spring Return Actuator, 1/8" NPT

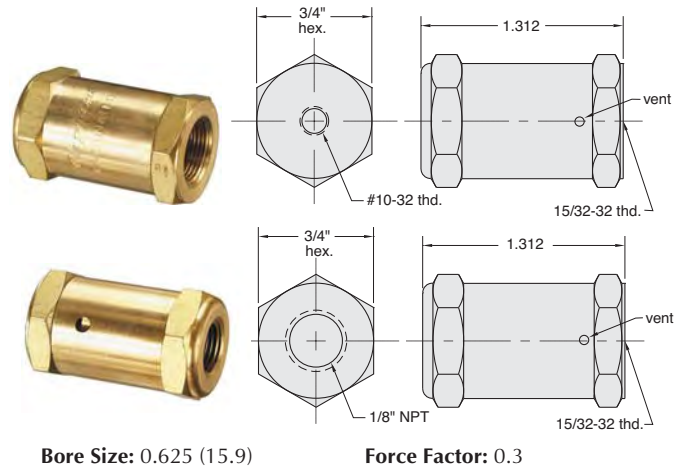

Bore Size: 0.625 (15.9)

Force Factor: 0.3

Part No.	Description
MPA-5	Single Acting, Spring Return Actuator, #10-32
MPA-5P	Single Acting, Spring Return Actuator, 1/8" NPT

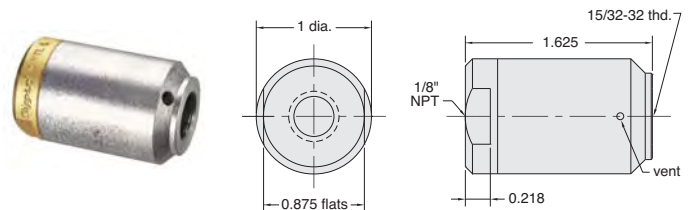

Bore Size: 0.875" (22.2) dia.

Force Factor: 0.6

Part No.	Description
MPA-7	Single Acting, Spring Return Actuator, 1/8" NPT

Pilot Actuators



Single Acting Spring Return Pilot Actuator

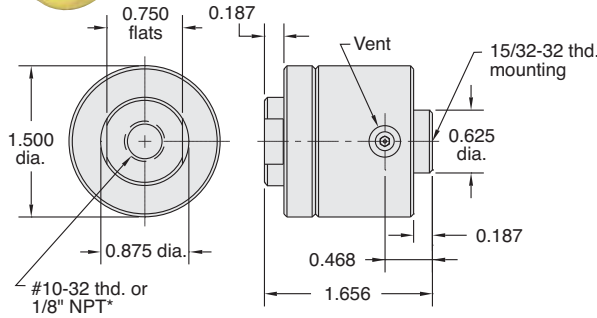

Bore Size: 1.250" dia.

Input Pressure: 150 psig max.

Mounting: #15/32-32 female thread to mount to Clippard Minimatic® valves and components; no spacers or washers are required when assembled to any Clippard valve; may be used with 15018-2 mounting bracket

Force Factor: 1.2

Part No.	Description
<u>MPA-10</u>	Single Acting, Spring Return Actuator, #10-32
<u>MPA-10P</u>	Single Acting, Spring Return Actuator, 1/8" NPT

Vacuum Actuators



Single Acting Spring Return Vacuum Actuator

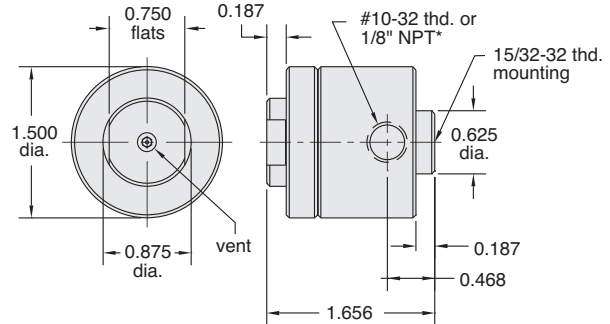

Input Pressure: 30 in. Hg

Mounting: #15/32-32 female thread to mount to Clippard Minimatic® valves and components; no spacers or washers are required when assembled to any Clippard valve; may be used with 15018-2 mounting bracket

Part No.	Description
<u>MVA-10</u>	Single Acting, Spring Vacuum Actuator, #10-32
<u>MVA-10P</u>	Single Acting, Spring Vacuum Actuator, 1/8" NPT

Push Button Actuators, 5/8"

Round Solid Brass 5/8" dia. Push Button

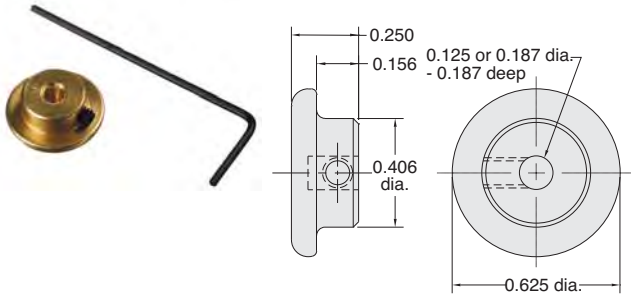

Use: Mounts directly on valve stem for manual operation of valve; prevents over-travel of valve stem by providing a positive stop

Mounting: 1/8" or 3/16" dia. mounting hole fits valve stems; locks in place by set screw (Allen wrench furnished)

Note: Individually packaged or bulk quantities available

Part No.	Description
<u>11916-1</u>	5/8" Brass Push Button, 1/8" Stem
<u>11916-2</u>	5/8" Brass Push Button, 3/16" Stem

Push Button Actuators, 13/32"

Round Solid Brass 13/32" dia. Push Button

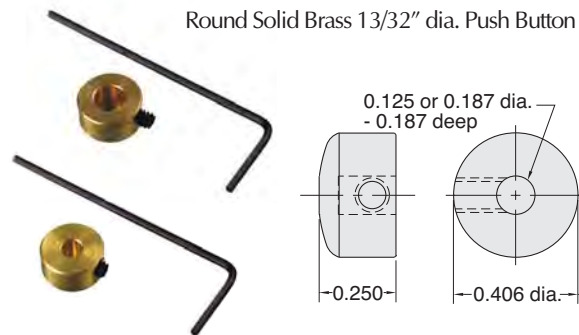

Use: Mounts directly on valve stem for manual operation of valve; small size permits attachment to valve before valve is mounted through 15/32" dia. hole; prevents over-travel of valve stem by providing a positive stop

Mounting: 1/8" or 3/16" dia. mounting hole fits valve stems; locks in place by set screw (Allen wrench furnished)

Note: Individually packaged or bulk quantities available

Part No.	Description
<u>11916-3</u>	13/32" Brass Push Button, 1/8" Stem
<u>11916-4</u>	13/32" Brass Push Button, 3/16" Stem

Captivated Push Buttons



Clippard also offers the captivated push button for use with a large variety of stem operated valves. Captivated push buttons are sold as kits, adaptable to either 1/8" diameter stems or 3/16" diameter stems. Each kit includes a colored acetyl push button, brass housing nut, 1/16" brass spacer, and lock washer for assembly. The standard furnished mounting nut has a bright chromate finish. Black chrome or nickel-plated finishes are also available by adding the suffix -BC or -ENP to the part number.

Captivated push buttons can be used on individual stem operated valves or in panel mount application by omitting the 1/16" brass spacer. These push buttons are available in a variety of colors, allowing you to color code, or easily differentiate between valves when designing control systems. The design of these push buttons allows maximum actuation of the valve with no over-travel or side load to the valve stem. This assures superior performance and long life.

Captivated push buttons are commonly used as limit valves in conjunction with pneumatic cylinders, slides, and any variety of mechanical actuators. The rugged design coupled with precise actuation of stem operated valves make it perfect for applications where repetitive cycling of the valve is necessary. Designed to work with Clippard MAV, MJV, and FV series, these push buttons integrate easily into Minimatic® systems, providing optimal quality and efficiency in Miniature pneumatic control.

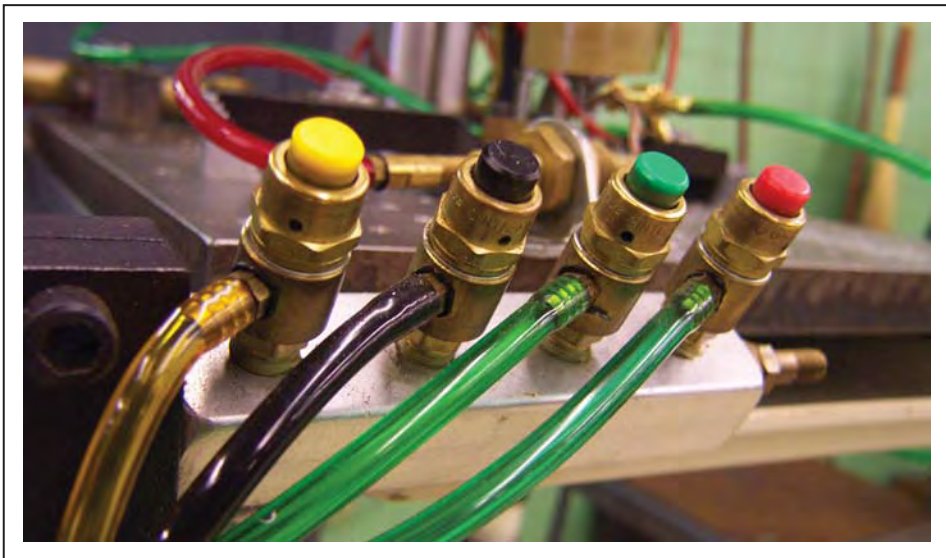
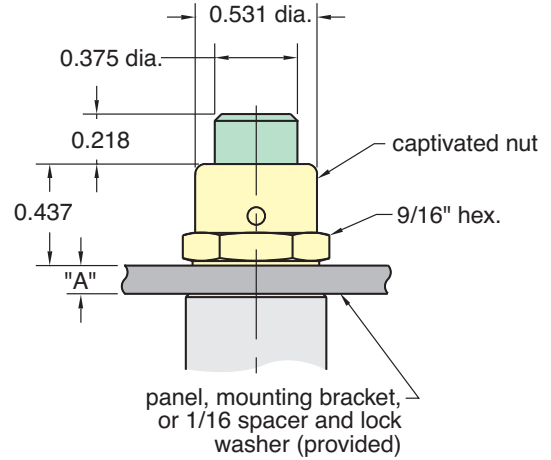
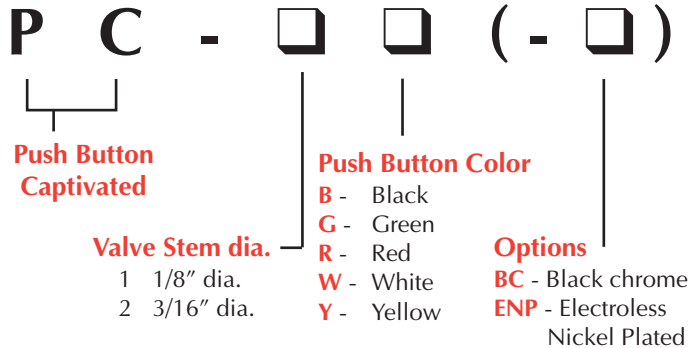
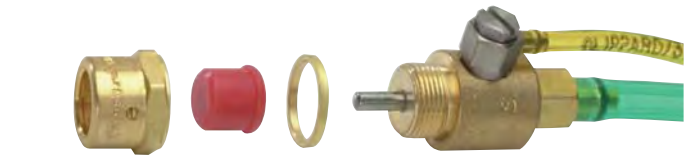

Spacing Required for Proper Actuation of Push Button

Valve	"A" Dim.
HV-3, HV-4 MAV-2, MAV-3 MAVO-2, MAVO-3	3/32"
MAV-4, MAV-4D MJV-4, MJV-4D	5/32"
FV-3, FV-4, FV-5 GV-3, GV-4 MJV-2, MJV-3 MJVO-2, MJVO-3	7/32"

Heavy-Duty Push Button Actuators

Heavy-Duty Push Button Actuators can be used on individual stem operated valves or in panel mounting applications. These push buttons are available in a variety of colors, allowing you to color code, or easily differentiate between valves when designing control systems. They feature a built-in spring so the button always returns to the extended position when released with no additional load on the valve.

The design of these push buttons allows complete actuation of the valve with no over-travel or side load to the valve assuring superior performance and long life.

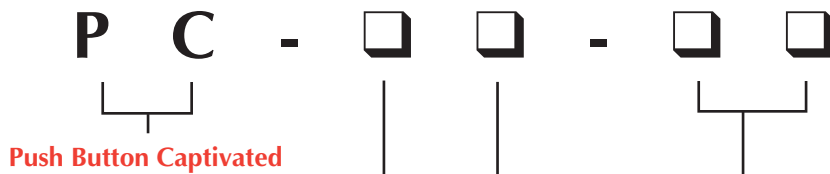

Size Mounting Thread
 3 - 5/8-32 thd. (16 mm)
 4 - 7/8-32 thd. (22 mm)
 5 - 1 3/16-28 thd. (30 mm)

Button Style
 E - Extended
 F - Flush
 M - Mushroom

Push Button color
 BK - Black WH - White RD - Red
 GN - Green YL - Yellow BL - Blue
 OR - Orange GR - Grey
 Note: Non-standard colors available; consult factory



Part No. **Description**
PC-3E-(color) 5/8-32 Thd., Extended
(specify color)



Part No. **Description**
PC-4E-(color) 7/8-32 Thd., Extended
(specify color)



Part No. **Description**
PC-5E-(color) 1 3/16-28 Thd., Extended
(specify color)



Part No. **Description**
PC-3F-(color) 5/8-32 Thd., Flush
(specify color)

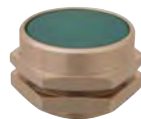

Part No. **Description**
PC-4F-(color) 7/8-32 Thd., Flush
(specify color)



Part No. **Description**
PC-5F-(color) 1 3/16-28 Thd., Flush
(specify color)



Part No. **Description**
PC-3M-(color) 5/8-32 Thd., Mushroom
(specify color)



Part No. **Description**
PC-4M-(color) 7/8-32 Thd., Mushroom
(specify color)



Part No. **Description**
PC-5M-(color) 1 3/16-28 Thd., Mushroom
(specify color)

Features

- Assembles directly to the valve; no adapters required
- Ideal for mounting on panels or brackets, up to 1/4" thick panel
- Self-contained assembly; no loose parts
- Stainless steel spring returns button to extended position with no added load to the valve stem
- Three sizes: 16 mm (5/8" dia.), 22 mm (7/8" dia.) and 30 mm (1-3/16" dia.)
- Flush, extended and mushroom style buttons
- Five bright colors for visibility and operator recognition. Other colors available upon request
- Electroless nickel plated brass housing and nut, molded Delrin® button and stainless steel spring for long life and corrosion resistance
- Protects the valve from over-travel and side load

Different valve models vary in mounting thread length, stem extension and stroke. To accommodate these differences, the chart below lists the recommended spacing ("S") to insure complete valve actuation. Provided with each button is a 1/16" thick spacer ring that may be used in place of a panel or bracket to obtain proper spacing. The lockwasher provided may be used with no significant effect on spacing.



DIMENSIONS

SIZE	MODEL	"D" Dia.	"H" Hgt.	"T" Thd.	"P" ^{+1/32} ₋₀ Panel Hole	"F" Hex Flats
5/8-32 (16 mm) mtg. thd.	PC-3E-□□	0.625"	0.734"			
	PC-3F-□□	0.625"	0.500"	5/8-32	5/8" dia.	3/4"
	PC-3M-□□	1.165"	0.906"			
7/8-32 (22 mm) mtg. thd.	PC-4E-□□	0.925"	0.734"			
	PC-4F-□□	0.925"	0.500"	7/8-32	7/8" dia.	1-1/16"
	PC-4M-□□	1.500"	0.906"			
1 3/16-28 (30 mm) mtg. thd.	PC-5E-□□	1.165"	0.734"			
	PC-5F-□□	1.165"	0.500"	1 3/16-28	1-3/16" dia.	1-5/16"
	PC-5M-□□	1.500"	0.906"			

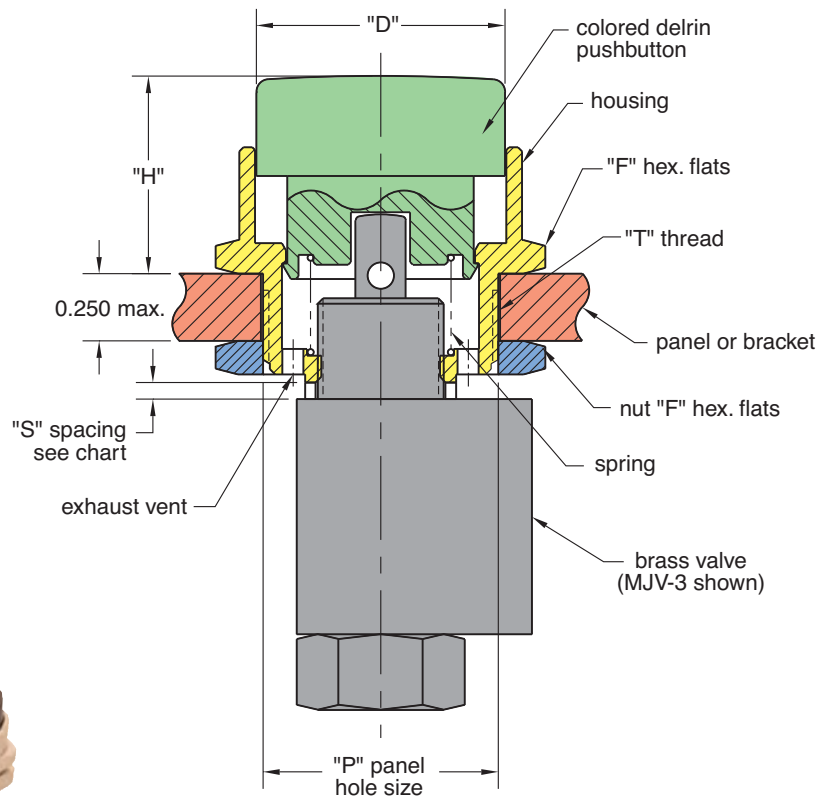

SPACING "S" REQUIRED FOR PROPER VALVE ACTUATION			
Valve series	MAV-2, MAVO-2 MAV-3, MAVO-3 HV-3, -4	MAV-4, -4D MJV-4, -4D	MJV-2, -3 MJVO-2, -3 FV-3, -4, -5 GV-2, -3
• Mounting thd.	1/4"	1/4"	3/8"
• Stem extension	5/16"	3/8"	5/16"
• Valve stroke	1/8"	3/16"	1/8"
"S" Minimum	none	none	1/16"
Maximum	1/16"	1/16"	1/8"

Minimatic® Actuators

Clippard's line of 22 mm and 30 mm actuators may be coupled with a variety of Clippard control valves with a simple adapter system providing a single assembly of a panel-mounted actuator and air valve.

The PB-22 and PB-30 have an aluminum housing that threads on to the actuator, and integral brass sleeve. The PB-22-X fits the 22 mm series actuators (P22-XXX), and the PB-30 fits the 30 mm series of actuators (PL-XXX). The PB-85 is made of plastic, and is compatible with 30 mm actuators only.

Step #1. Select **Actuator** on [pages 143 through 144](#).

Step #2. Determine spacing requirements using the chart on [page 143](#).

Step #3. Determine **Adapter** on [pages 143 and 144](#).

Step #4. Add **Accessories** on [page 145](#).

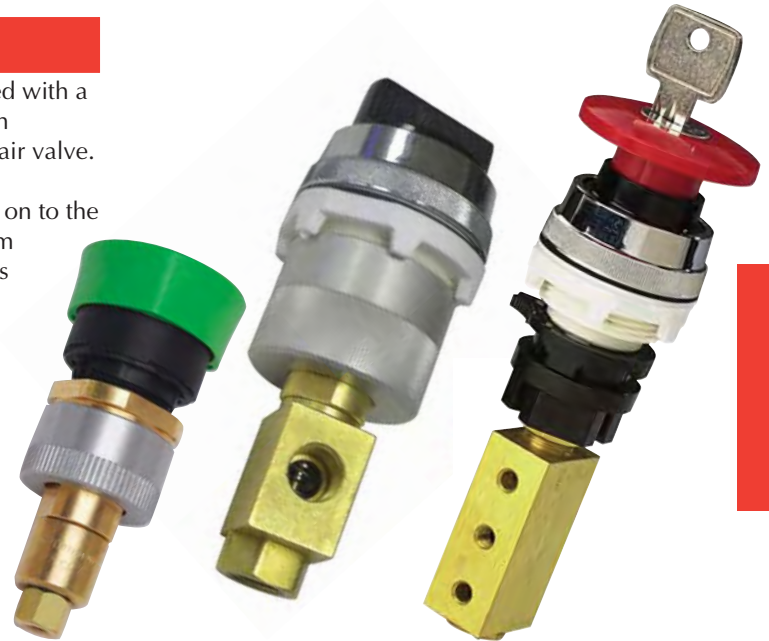

PB-22-X Adapter (22 mm) PB-30 Adapter (30 mm) PB-85 Adapter (30 mm)

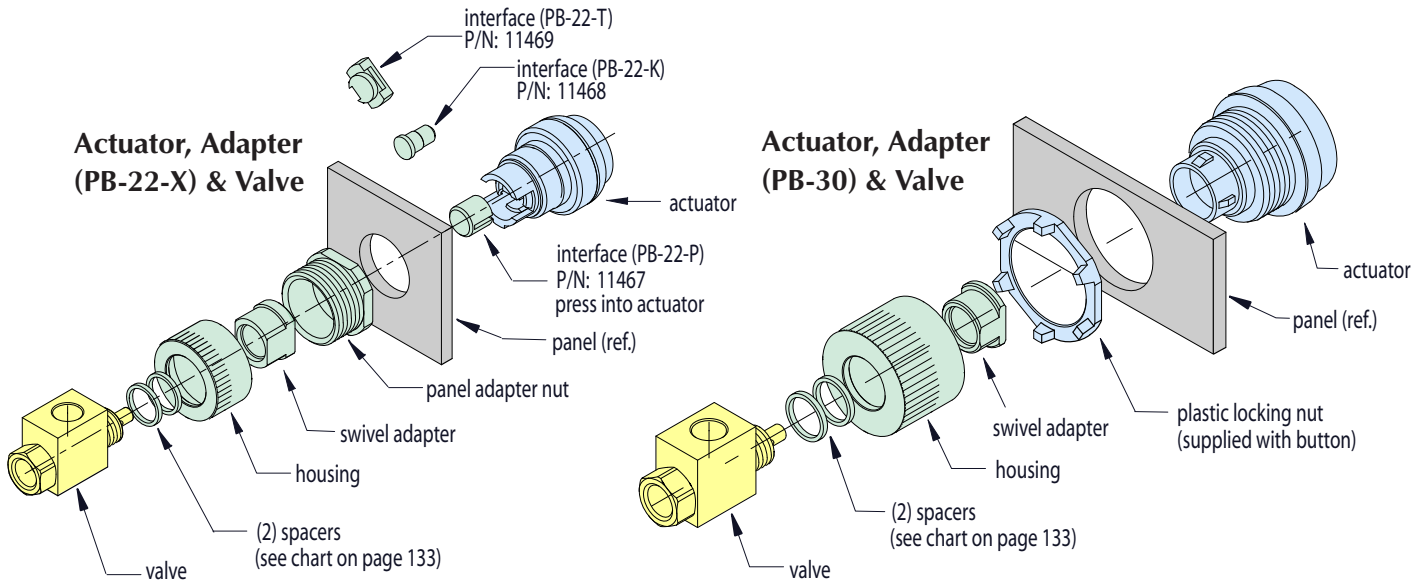

Actuator Ordering Guide

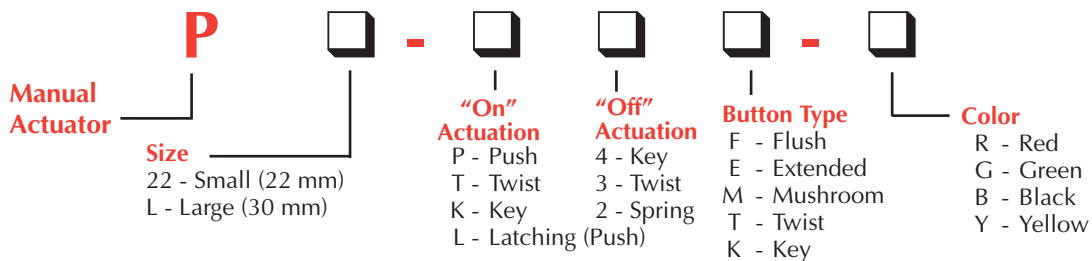

Size 22 mm Actuators

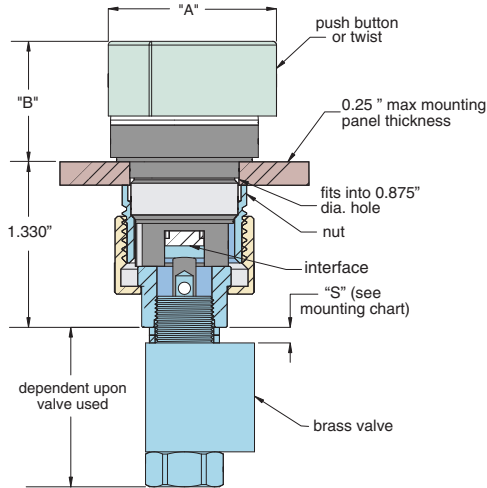

PB-22-X Adapter			
Actuator	Adapter	"A"	"B"
P22-P2F-	PB-22-P	1.200"	0.450"
P22-P2E-	PB-22-P	1.200"	0.650"
P22-P2M-	PB-22-P	1,600"	0.850"
P22-L3M-	PB-22-K	1.450"	1.000"
P22-L4M-	PB-22-K	1.450"	1.200"
P22-T2T-	PB-22-T	1.200"	0.925"
P22-T3T-	PB-22-T	1.200"	0.925"
P22-T3K-	PB-22-T	1.200"	1.000"
P22-K3K-	PB-22-T	1.200"	1.000"

Mounting Chart for Clippard Valves

The following chart gives the necessary spacing required between the shoulder of the valve and the base of the adapter. Two 1/16" spacers are furnished with each adapter.

Spacer Requirements

Valves	"S"
HV-3, -4,	None
MAV-2, -2P, -2R, -3R, -3, -3P	
GV-2, -3	1/8"
MJV-2, -3	
MJVO-2, -3	None
MAV-4, -4D	
MJV-4, -4D	None
ES-1	
FV-3, -3P, -3D, -3DP	1/8"
FV-4, -4P, -4D, -4DP	
FV-5, -5P, -5D, -5DP	



Flush Push Button. Manual Push "In". Spring Return.

Part No.	Description
P22-P2F-R	Red
P22-P2F-G	Green
P22-P2F-B	Black
P22-P2F-Y	Yellow



Extended Push Button. Manual Push "In". Spring Return.

Part No.	Description
P22-P2E-R	Red
P22-P2E-G	Green
P22-P2E-B	Black
P22-P2E-Y	Yellow



Automatic Push/Turn Mushroom. Manual push "In". Latches "In". Turn clockwise to unlatch. Spring return.

Part No.	Description
P22-L3M-R	Red
P22-L3M-G	Green
P22-L3M-B	Black



Maintained Twist 90°. Turn clockwise to latch "In". Turn counterclockwise to release. Black only.

Part No.	Description
P22-T3T-B	Black



Spring Return Twist 45°. Turn clockwise and hold for "In". Release for spring return. Black only.

Part No.	Description
P22-T2T-B	Black



Manual Push Mushroom. Manual Push "In". Spring Return.

Part No.	Description
P22-P2M-R	Red
P22-P2M-G	Green
P22-P2M-B	Black



Key Twist 90° Maintained. (P22-T3K-B) Turn key clockwise to latch "In". Turn key counterclockwise to release. Key withdrawable in both positions. Black only.

P22-K3K-B same as P22-T3K-B except key is withdrawable in "Out" position only.

Part No.	Description
P22-T3K-B	Black
P22-K3K-B	Black



Push Key Mushroom. Manual push "In". Automatic latches "In". Turn key clockwise to release. Spring return. Key withdrawable "Out" position only. Red only.

Part No.	Description
P22-L4M-R	Red



Size 30 mm Actuators

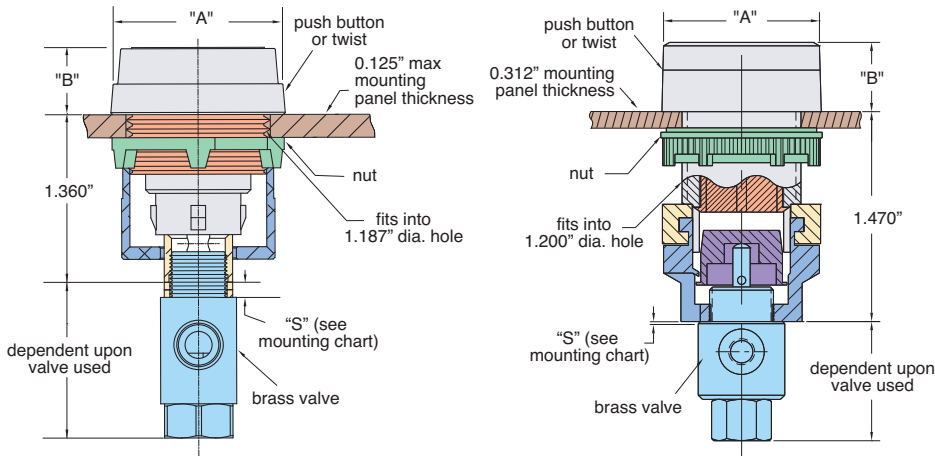

Automatic Push/Turn Mushroom. Manual push "In". Latches "In". Turn clockwise to unlatch. Spring return.

Part No.	Description
PL-L3M-R	Red
PL-L3M-G	Green
PL-L3M-B	Black



Manual Push Mushroom. Manual push "In". Spring return.

Part No.	Description
PL-P2M-R	Red
PL-P2M-G	Green
PL-P2M-B	Black



Spring Return Twist 45°. Turn clockwise and hold for "In". Release for spring return. Black only.

Part No.	Description
PL-T2T-B	Black



Push Key Push Button. Manual push "In". Spring return. Turn key

Part No.	Description
PL-P4K-B	Black



Key Twist 90° Maintained. (PL-T3K-B) Turn key clockwise to latch "In". Turn key counterclockwise to release. Key withdrawable in both positions. Black only.

Part No.	Description
PL-T3K-B	Black
PL-K3K-B	Black

PB-30 Aluminum Adapter		
Actuator	"A"	"B"
PL-P2F-	1.440"	0.580"
PL-P2E-	1.440"	0.880"
PL-P2M-	1.560"	1.050"
PL-L3M-	1.560"	1.050"
PL-P4K-	1.440"	1.400"
PL-L4M-	1.580"	1.300"
PL-T2T-	1.440"	1.070"
PL-T3T-	1.440"	1.070"
PL-T3K-	1.440"	1.200"
PL-K3K-	1.440"	1.200"

PB-85 Plastic Adapter		
Actuator	"A"	"B"
PL-P2F-	1.440"	0.550"
PL-P2E-	1.440"	0.960"
PL-P2M-	1.575"	1.043"
PL-L3M-	1.575"	1.043"
PL-P4K-	1.440"	2.280"
PL-L4M-	1.575"	2.280"
PL-T2T-	1.440"	1.403"
PL-T3T-	1.440"	1.043"
PL-T3K-	1.440"	2.280"
PL-K3K-	1.440"	2.280"

Part No.	Description
PB-30	Aluminum Adapter
PB-85	Plastic Adapter



Flush Push Button. Manual push "In". Spring return.

Part No.	Description
PL-P2F-R	Red
PL-P2F-G	Green
PL-P2F-B	Black
PL-P2F-Y	Yellow



Maintained Twist 90°. Turn clockwise to latch "In". Turn counterclockwise to release. Black only.

Part No.	Description
PL-T3T-B	Black



Extended Push Button. Manual push "In". Spring return.

Part No.	Description
PL-P2E-R	Red
PL-P2E-G	Green
PL-P2E-B	Black
PL-P2E-Y	Yellow



Push Key Mushroom. Manual push "In". Automatic latches "In". Turn key clockwise to release. Spring return. Key withdrawable "Out" position only. Red only.

Part	Description
PL-L4M-R	Red

Legend Plates

Legend Text	22 Size Part #	30 Size Part #
Blank	P22-01	PL-01
Start	P22-02	PL-02
Stop (red)	P22-03	PL-03
Forward	P22-04	PL-04
Reverse	P22-05	PL-05
Fast	P22-06	PL-06
Slow	P22-07	PL-07
On	P22-08	PL-08
Off (red)	P22-09	PL-09
Reset	P22-10	PL-10
Raise	P22-11	PL-11
Lower	P22-12	PL-12
Emergency Stop (red)	P22-13	PL-13
Run / Jog	P22-31	PL-31
Auto / Hand	P22-32	PL-32
Forward / Reverse	P22-33	PL-33
Fast / Slow	P22-34	PL-34
Open / Close	P22-35	PL-35
Up / Down	P22-36	PL-36
Off / On	P22-37	PL-37

Mounting Clippard Manual Actuators

These drill plans are for units fitted with optional anti-rotation ring

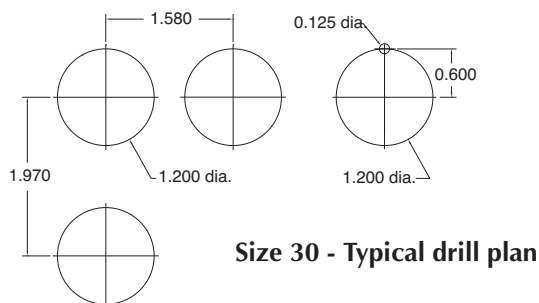
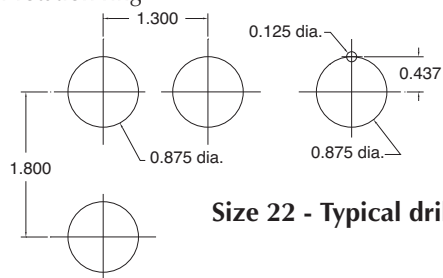

Legend Plates

Plastic legend plate, two sizes, with a black field and white inscription (red as noted). Inscription plates are interchangeable in both sizes.



Accessories for Manual Actuators

Mounting Wrench

Fits 30 mm size manual actuators.

Part No.	Description
PB-60	Mounting Wrench



Replacement Interface

Part No.	Description
11468	PB-22-K Interface
11467	PB-22-P Interface
11469	PB-22-T Interface



Replacement 30 mm Anti-Rotation Ring

Holds 30 mm adapter in one position. Included with all 30 mm twist manual actuators.

Part No.	Description
PL-50	Anti-Rotation Ring, 30 mm



22 mm Anti-Rotation Feature

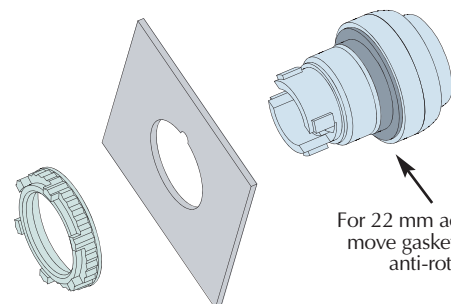

For 22 mm actuators, remove gasket to enable anti-rotation.

Flat Bracket



Flat bracket designed to mount 2010, 2011-1, 2012 and 2013 valves

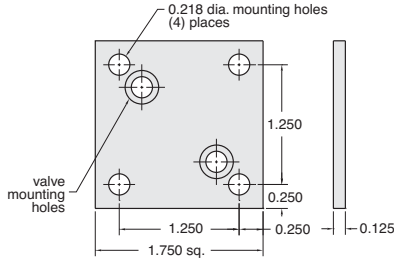

Construction: Black anodized finish, two mounting screws furnished.

Part No.	Description
2010-050	Flat Bracket

Bracket for Action Relays



Mounting bracket for 3200-A snap action relays.

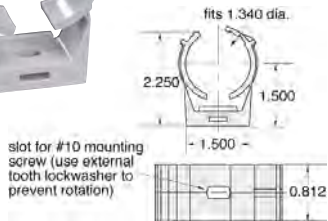

Part No.	Description
3200-006	Snap Action Relay Bracket

Rubber Nozzles



#10-32 rubber nozzles for replacement 2011-1 limit valves. #10-32 thread, five to a package

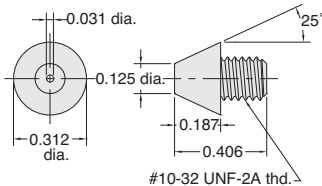

Part No.	Description
2011-012	Rubber Nozzles

Metal Foot Bracket



90° angle, metal foot bracket for Clippard miniature valves

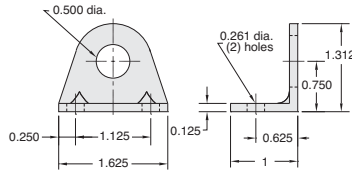

Mounting: 1/2" dia. hole for valve; two 0.261" dia. holes for attaching bracket

Construction: Stamped from 1/8" thick steel, zinc plated

Part No.	Description
15018-2	Foot Mounting Bracket

Metal Foot Bracket



90° angle, metal foot bracket for Clippard miniature valves

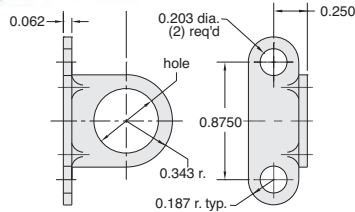

Mounting: 31/64" dia. mounting hole for valve; two 13/64" dia. mounting holes for attaching bracket

Construction: Stamped from 1/16" thick steel, zinc plated

Part No.	Description
11918-1	Bracket, 0.484" Hole
11918-2	Bracket, 0.328" Hole

1/8" NPT Filter



1/8" NPT hex nipple with 40 micron filter / strainer, can be used as a muffler

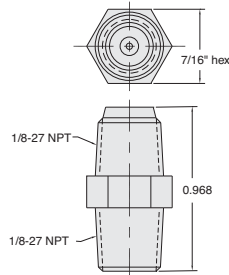

Part No.	Description
9002-01	1/8" NPT Filter

Flat Metal Bracket



Flat metal bracket, for mounting Clippard miniature valves

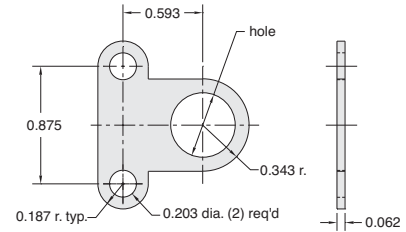

Mounting: 31/64" dia. mounting hole for valve; two 13/64" dia. mounting holes for attaching bracket

Construction: Stamped from 1/16" thick steel, zinc plated

Part No.	Description
11917-1	Metal Bracket, 0.484 Hole
11917-2	Metal Bracket, 0.328 Hole

See Page 328 for a complete offering of In-Line Manifolds

CUSTOMer solutions

If you need a product that fits your application perfectly, Clippard has the capability to design or modify one of its products to suit your exact needs. We understand that a standard catalog product may be close but not be exactly what you need. **Let us know YOUR Need, and we will help to find YOUR Solution!**

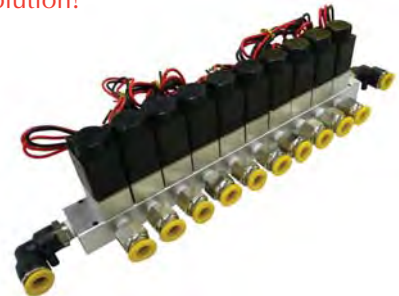

For more information, visit www.clippard.com/customsolutions