



**Push-Quick Fittings . . . . . 304 - 312**

Fittings are easy to install, and provide high flow. Threaded and non-threaded available.



**Barb Fittings . . . . . 313 - 320**

Fittings are available with 1/16", 3/32" or 1/8" hose barbs, #10-32 thread and 1/8" NPT.



**Compression Fittings . . . . . 320**

Join standard size pipe to tubing with a convenient ferrule design.



**Nipples & Couplings . . . . . 321 - 322**

Used for coupling various cylinders, valves, fittings and other components together.



**Threaded Fittings . . . . . 322**

Offered with #10-32 and 1/8" NPT threads. "L", "T" and "X" configurations.



**Adapters & Reducers . . . . . 323 - 324**

Adapt your fittings to the right positions and threads.



**Bulkhead Fittings . . . . . 324**

Provide rigid connection through panels or bulkheads up to 1/2" thick.



## Plugs .....324

Offered for use to plug unused openings in fittings, manifolds and more.



## Mufflers .....326

Provides muffled exhaust for quiet system operation.

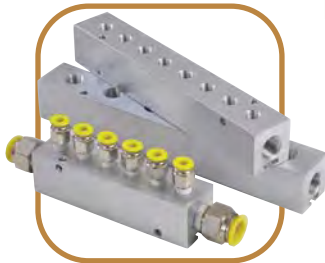

## Manifolds .....326 - 327

Ideal for grouping pneumatic valves and other components in applications where space is limited.



## Quick Connect Fittings .....329 - 332

A body and cap assembly which enables fast and easy connection, and tight shut-off when disconnected.



## Air Jets .....333

Deliver a concentrated flow of air or liquid to a designated location.



## Fittings Kits .....334 - 335

A variety of the most commonly used fittings and quick connects to save time and avoid delays.



## Hose & Tubing .....336 - 341

Sizes from 1/8" to 1/2" OD in various materials, colors and styles.

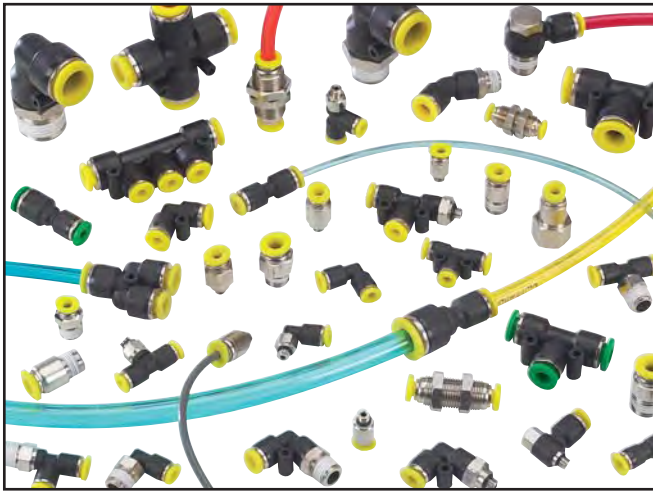

Clippard Push-Quick Fittings provide a simple method of connecting pneumatic components to each other and system piping. They are designed for use with both flexible hose and stiff tubing made of nylon, urethane, polyethylene or polypropylene.

Push-Quick Fittings generally provide higher flows than barbed fittings. The Push-Quick fitting allows full flow through the hose/tubing I.D. with no smaller orifice required as in barb fittings. The chart shows the comparison between barb and push in fittings for various tubing/hose sizes. Push-Quick Fittings are available in nine sizes for 1/8", 5/32", 6 mm, 1/4" and 3/8" O.D. tubing. The 5/32" fittings may also be used with 4 mm O.D. tubing.

**Pressure Range:** 0 - 150 psig @ 130°F

**Vacuum:** 0 to 29.5" Hg

**Temperature Range:** 32 to 140°F

**Media:** Air, Non-corrosive water

**Tube Pull Out Force:** >20 lb. @ 75°F (non-pressurized)

**Burst Pressure:** 350 psig @ 75°F

**Materials:** Body - Plastic Resin  
Metal Stud - Nickel Plated Brass  
Gripper Ring - Stainless Steel  
Seals - Nitrile

### Installation of Tubing into fitting

1. Slowly push a clean and perpendicularly cut tubing into the fitting until it comes to a dead stop.
2. Pull the tubing back gently until the Gripper Ring of the fitting grips onto the tubing and has a good seal.

### Removal of Tubing from fitting

1. Push in evenly on the two long oval sides of the Release Button.
2. Pull out the tubing while keeping the Release Button depressed.
3. To reuse the tubing; cut off the lodged portion of the previously used tubing evenly and perpendicularly.

### Installation of Pipe Fittings with Pre-Applied sealant

1. Tighten fitting by hand, then turn it 2 or 3 turns with a wrench until it reaches the desired torque listed.
2. If the fitting is used and the sealant coating is not in good condition, apply Teflon® sealant tape to the threads.



\* 6 mm size fittings have a green release button

Thread Size	#10-32	1/8" NPT, R1/8	1/4" NPT, R1/4	3/8" NPT	1/2" NPT
Torque lb. - ft.	1.0 - 1.5	5.0 - 6.5	8.5 - 10.0	16.0 - 17.5	20 - 21.5

Tubing Material	Polyurethane	Polyethylene	Polypropylene	Nylon
Specified Size	+/- 0.005"	+/- 0.004"	+/- 0.004"	+/- 0.004"
Hardness (Durometer)	Shore A85 or higher	Shore D 44 or higher	Shore D 44 or higher	Shore D 44

see [pages 322 through 327](#) for hose and tubing

Barb vs Push-Quick Fittings  
Flow Comparison @ 100 psig

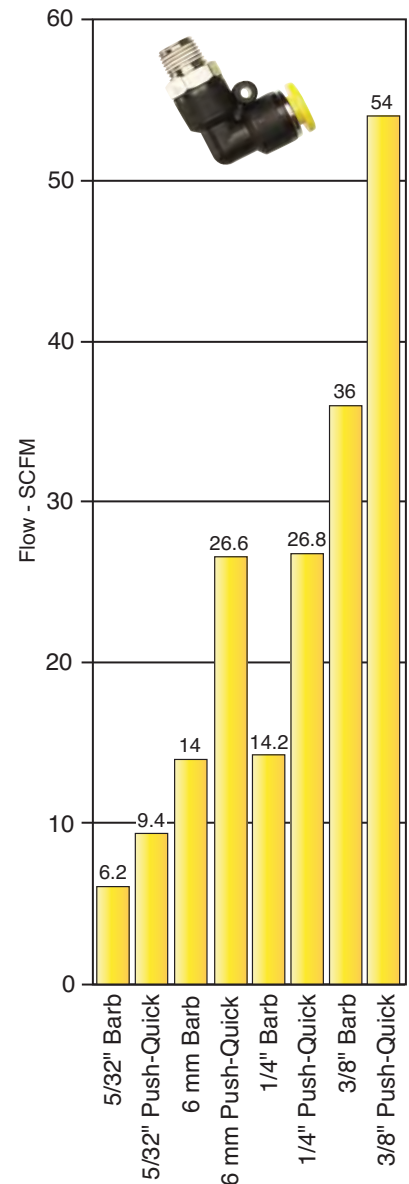



Fitting Type		Tubing Size (O.D.)	Thread Size
<b>BC</b> - Bulkhead Connector	<b>MA</b> - Male Angle Connector	<b>RU</b> - Reduced Union	<b>N</b> - #10-32
<b>BT</b> - Branch Tee	<b>MC</b> - Male Connector	<b>SC</b> - Stem Coupler	<b>5</b> - M5 Thd.
<b>BU</b> - Bulkhead Union	<b>ME</b> - Male Elbow	<b>SE</b> - Stack Elbow	<b>6</b> - M6 Thd.
<b>CC</b> - Compact Male Conn.	<b>MM</b> - Male Manifold	<b>SR</b> - Stem Reducer	<b>P</b> - 1/8" NPT
<b>CU</b> - Cross Union	<b>MU</b> - Manifold Union	<b>SU</b> - Straight Union	<b>R</b> - R1/8
<b>EE</b> - Extended Elbow	<b>PE</b> - Plug-In Elbow	<b>TU</b> - Tee Union	<b>Q</b> - 1/4" NPT
<b>ER</b> - Elbow Reducer	<b>PG</b> - Plug	<b>TR</b> - Tube Reducer	<b>2</b> - R1/4
<b>EU</b> - Elbow Union	<b>RB</b> - Reduced Branch	<b>UE</b> - Universal Elbow	<b>W</b> - 3/8" NPT
<b>FC</b> - Female Connector	<b>RT</b> - Run Tee	<b>YC</b> - Y Connector	<b>3</b> - R3/8
<b>FE</b> - Female Elbow		<b>YU</b> - Y Union	<b>Z</b> - 1/2" NPT
			<b>04</b> - 1/8" (0.125")
			<b>04M</b> - 4 mm (0.157")
			<b>05</b> - 5/32" (0.156")
			<b>06M</b> - 6 mm (0.236")
			<b>08</b> - 1/4" (0.250")
			<b>08M</b> - 8 mm (0.313")
			<b>10</b> - 5/16" (0.313")
			<b>12</b> - 3/8" (0.375")
			<b>16</b> - 1/2" (0.500")

## Threaded Fittings



**Female Connector**  
[Page 306](#)



**Male Compact Connector**  
[Page 306](#)



**Male Connector**  
[Page 306](#)



**Bulkhead Connector**  
[Page 310](#)



**Male Angle Connector**  
[Page 309](#)



**Y Connector**  
[Page 308](#)



**Female Elbow**  
[Page 308](#)



**Male Elbow**  
[Page 307](#)



**Extended Elbow**  
[Page 308](#)



**Universal Elbow**  
[Page 308](#)



**Stack Elbow**  
[Page 309](#)



**Run Tee**  
[Page 307](#)



**Branch Tee**  
[Page 307](#)



**Manifold Mount**  
[Page 309](#)

## Non-Threaded Fittings



**Straight Union**  
[Page 310](#)



**Reduced Union**  
[Page 311](#)



**Elbow Union**  
[Page 310](#)



**Tee Union**  
[Page 310](#)



**Y Union**  
[Page 311](#)



**Cross Union**  
[Page 310](#)



**Manifold Union**  
[Page 310](#)



**Bulkhead Union**  
[Page 310](#)



**Reduced Branch**  
[Page 311](#)



**Elbow Reducer**  
[Page 311](#)



**Tube Reducer**  
[Page 311](#)



**Plug-In Elbow**  
[Page 311](#)



**Tee Reducer**  
[Page 311](#)



**Stem Reducer**  
[Page 312](#)



**Stem Coupler**  
[Page 312](#)

## Female Connector

(10/pack)

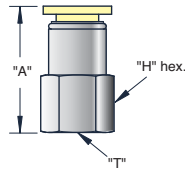

Tubing	Thread "T"	Part No.	"A"	"H" Hex.
5/32"	#10-32	<a href="#">PQ-FC05N</a>	0.905"	7/16"
	1/8" NPT	<a href="#">PQ-FC05P</a>	1.080"	9/16"
4 mm*	M5 x 0.8	<a href="#">PQ-FC04M5</a>	0.905"	12 mm
	R1/8	<a href="#">PQ-FC04MR</a>	1.080"	
6 mm*	R1/8	<a href="#">PQ-FC06MR</a>	1.080"	14 mm
	R1/4	<a href="#">PQ-FC06M2</a>	1.100"	17 mm
1/4"	1/8" NPT	<a href="#">PQ-FC08P</a>	1.080"	9/16"
	1/4" NPT	<a href="#">PQ-FC08Q</a>	1.220"	11/16"
5/16"	1/8" NPT	<a href="#">PQ-FC10P</a>	1.170"	11/16"
	1/4" NPT	<a href="#">PQ-FC10Q</a>	1.250"	11/16"
	3/8" NPT	<a href="#">PQ-FC10W</a>	1.260"	7/8"
8 mm*	R1/8	<a href="#">PQ-FC08MR</a>	1.170"	17 mm
	R1/4	<a href="#">PQ-FC08M2</a>	1.170"	17 mm
	R3/8	<a href="#">PQ-FC08M3</a>	1.250"	19 mm
3/8"	1/4" NPT	<a href="#">PQ-FC12Q</a>		
	3/8" NPT	<a href="#">PQ-FC12W</a>	1.380"	7/8"

## Male Connector

(10/pack)

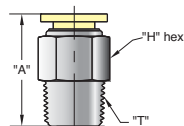

Tubing	Thread "T"	Part No.	"A"	"H" Hex.
1/8"	#10-32	<a href="#">PQ-MC04N</a>	0.899"	
	1/8" NPT	<a href="#">PQ-MC04P</a>	0.836"	7/16"
	1/4" NPT	<a href="#">PQ-MC04Q</a>	0.920"	
5/32"	#10-32	<a href="#">PQ-MC05N</a>	0.899"	7/16"
	1/8" NPT	<a href="#">PQ-MC05P</a>	0.836"	7/16"
	1/4" NPT	<a href="#">PQ-MC05Q</a>	0.920"	9/16"
4 mm*	M5 x 0.8	<a href="#">PQ-MC04M5</a>	0.899"	10 mm
	R1/8	<a href="#">PQ-MC04MR</a>	0.836"	
6 mm*	M5 x 0.8	<a href="#">PQ-MC06M5</a>	0.948"	12 mm
	R1/8	<a href="#">PQ-MC06MR</a>	0.878"	12 mm
	R1/4	<a href="#">PQ-MC06M2</a>	0.873"	14 mm
1/4"	#10-32	<a href="#">PQ-MC08N</a>	0.913"	1/2"
	1/8" NPT	<a href="#">PQ-MC08P</a>	0.913"	1/2"
	1/4" NPT	<a href="#">PQ-MC08Q</a>	0.965"	9/16"
	3/8" NPT	<a href="#">PQ-MC08W</a>	0.965"	11/16"
5/16"	1/8" NPT	<a href="#">PQ-MC10P</a>	1.090"	9/16"
	1/4" NPT	<a href="#">PQ-MC10Q</a>	1.050"	9/16"
	3/8" NPT	<a href="#">PQ-MC10W</a>	1.060"	11/16"
8 mm*	M5 x 0.8	<a href="#">PQ-MC08M5</a>	1.030"	14 mm
	R1/8	<a href="#">PQ-MC08MR</a>	1.030"	14 mm
	R1/4	<a href="#">PQ-MC08M2</a>	1.060"	14 mm
	R3/8	<a href="#">PQ-MC08M3</a>	0.950"	17 mm
3/8"	1/8" NPT	<a href="#">PQ-MC12P</a>	1.280"	11/16"
	1/4" NPT	<a href="#">PQ-MC12Q</a>	1.342"	11/16"
	3/8" NPT	<a href="#">PQ-MC12W</a>	1.241"	11/16"
	1/2" NPT	<a href="#">PQ-MC12Z</a>	1.240"	7/8"
1/2"	1/4" NPT	<a href="#">PQ-MC16Q</a>	1.342"	11/16"
	3/8" NPT	<a href="#">PQ-MC16W</a>	1.241"	7/8"
	1/2" NPT	<a href="#">PQ-MC16Z</a>	1.240"	7/8"

## Male Compact Connector

(10/pack)

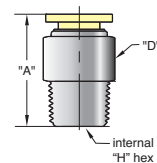

Tubing	Thread "T"	Part No.	"A"	"D" Dia.	"H" Hex.
1/8"	#10-32	<a href="#">PQ-CC04N</a>	0.880"	0.410"	5/64"
	1/8" NPT	<a href="#">PQ-CC04P</a>	0.860"		3/32"
5/32"	#10-32	<a href="#">PQ-CC05N</a>	0.890"	0.400"	5/64"
	1/8" NPT	<a href="#">PQ-CC05P</a>	0.840"	0.410"	3/32"
1/4"	#10-32	<a href="#">PQ-CC08N</a>	0.910"	0.470"	5/64"
	1/8" NPT	<a href="#">PQ-CC08P</a>	0.910"	0.470"	5/32"
	1/4" NPT	<a href="#">PQ-CC08Q</a>	0.970"	0.530"	5/32"
3/8"	1/4" NPT	<a href="#">PQ-CC12Q</a>	1.340"	0.670"	7/32"
	3/8" NPT	<a href="#">PQ-CC12W</a>	1.240"		5/16"

\* Fittings have a green release button.

Note: Fittings with pipe thread NPT, R1/8, R1/4 and R3/8 are supplied with pre-applied sealant.



## Run Tee

(5/pack)

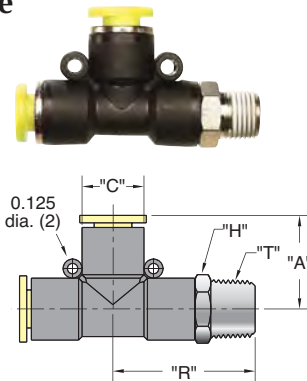

Tubeing	Thread "T"	Part No.	"A"	"C"	"H" Hex.	"R"
1/8"	1/8" NPT	PQ-RT04P	0.722"	0.410"	7/16"	0.980"
5/32"	#10-32	<a href="#">PQ-RT05N</a>	0.722"	0.410"	7/16"	0.900"
	1/8" NPT	<a href="#">PQ-RT05P</a>				0.980"
4 mm*	M5 x 0.8	<a href="#">PQ-RT04M5</a>	0.722"	0.410"	10 mm	0.900"
	R1/8	<a href="#">PQ-RT04MR</a>				0.980"
6 mm*	M5 x 0.8	<a href="#">PQ-RT06M5</a>			12 mm	1.030"
	R1/8	<a href="#">PQ-RT06MR</a>	0.830"	0.524"	12 mm	1.100"
	R1/4	<a href="#">PQ-RT06M2</a>			14 mm	1.140"
1/4"	#10-32	<a href="#">PQ-RT08N</a>			1/2"	1.030"
	1/8" NPT	<a href="#">PQ-RT08P</a>	0.840"	0.524"	1/2"	1.100"
	1/4" NPT	<a href="#">PQ-RT08Q</a>			9/16"	1.230"
5/16"	1/8" NPT	<a href="#">PQ-RT10P</a>			9/16"	1.100"
	1/4" NPT	<a href="#">PQ-RT10Q</a>	0.880"	0.580"	9/16"	1.230"
	3/8" NPT	<a href="#">PQ-RT10W</a>			11/16"	1.290"
8 mm*	R1/8	<a href="#">PQ-RT08MR</a>			14 mm	1.290"
	R1/4	<a href="#">PQ-RT08M2</a>	0.880"	0.580"		
	R3/8	<a href="#">PQ-RT08M3</a>				
3/8"	1/8" NPT	<a href="#">PQ-RT12P</a>			11/16"	1.380"
	1/4" NPT	<a href="#">PQ-RT12Q</a>	1.100"	0.720"		1.470"
	3/8" NPT	<a href="#">PQ-RT12W</a>				1.500"

## Branch Tee

(5/pack)

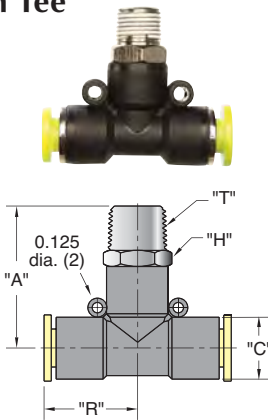

Tubeing	Thread "T"	Part No.	"A"	"C"	"H" Hex.	"R"
5/32"	#10-32	<a href="#">PQ-BT05N</a>	0.900"	0.410"	7/16"	0.722"
	1/8" NPT	<a href="#">PQ-BT05P</a>	0.980"			
4 mm*	M5 x 0.8	<a href="#">PQ-BT04M5</a>	0.900"	0.410"	10 mm	0.722"
	R1/8	<a href="#">PQ-BT04MR</a>	0.980"			
6 mm*	M5 x 0.8	<a href="#">PQ-BT06M5</a>	1.030"		12 mm	
	R1/8	<a href="#">PQ-BT06MR</a>	1.100"	0.524"	12 mm	0.830"
	R1/4	<a href="#">PQ-BT06M2</a>	1.140"		14 mm	
1/4"	#10-32	<a href="#">PQ-BT08N</a>	1.030"		1/2"	
	1/8" NPT	<a href="#">PQ-BT08P</a>	1.100"	0.524"	1/2"	0.840"
	1/4" NPT	<a href="#">PQ-BT08Q</a>	1.230"		9/16"	
5/16"	1/8" NPT	<a href="#">PQ-BT10P</a>	1.100"		9/16"	
	1/4" NPT	<a href="#">PQ-BT10Q</a>	1.230"	0.580"		0.880"
8 mm*	R1/8	<a href="#">PQ-BT08MR</a>			14 mm	
	R1/4	<a href="#">PQ-BT08M2</a>	1.290"	0.580"		0.880"
	R3/8	<a href="#">PQ-BT08M3</a>				
3/8"	1/8" NPT	<a href="#">PQ-BT12P</a>	1.290"		11/16"	
	1/4" NPT	<a href="#">PQ-BT12Q</a>	1.470"	0.720"		1.100"
	3/8" NPT	<a href="#">PQ-BT12W</a>	1.500"			

## Male Elbow

(10/pack)

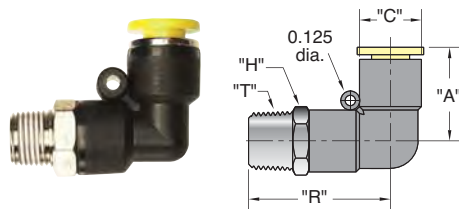

Tubeing	Thread "T"	Part No.	"A"	"C"	"H" Hex.	"R"
1/8"	#10-32	<a href="#">PQ-ME04N</a>			7/16"	0.900"
	1/8" NPT	<a href="#">PQ-ME04P</a>	0.722"	0.410"		0.980"
5/32"	#10-32	<a href="#">PQ-ME05N</a>			7/16"	0.900"
	1/8" NPT	<a href="#">PQ-ME05P</a>	0.722"	0.410"		0.980"
	1/4" NPT	<a href="#">PQ-ME05Q</a>				1.130"
4 mm*	M5 x 0.8	<a href="#">PQ-ME04M5</a>	0.722"	0.410"	10 mm	0.900"
	R1/8	<a href="#">PQ-ME04MR</a>				0.980"
6 mm*	M5 x 0.8	<a href="#">PQ-ME06M5</a>			12 mm	1.030"
	R1/8	<a href="#">PQ-ME06MR</a>	0.830"	0.524"	12 mm	1.100"
	R1/4	<a href="#">PQ-ME06M2</a>			14 mm	1.140"
1/4"	#10-32	<a href="#">PQ-ME08N</a>			1/2"	1.030"
	1/8" NPT	<a href="#">PQ-ME08P</a>			1/2"	1.100"
	1/4" NPT	<a href="#">PQ-ME08Q</a>	0.840"	0.524"	9/16"	1.230"
	3/8" NPT	<a href="#">PQ-ME08W</a>			11/16"	1.290"
	1/8" NPT	<a href="#">PQ-ME10P</a>			9/16"	1.100"
5/16"	1/4" NPT	<a href="#">PQ-ME10Q</a>	0.880"	0.580"	9/16"	1.230"
	3/8" NPT	<a href="#">PQ-ME10W</a>			11/16"	1.290"
8 mm*	R1/8	<a href="#">PQ-ME08MR</a>			14 mm	1.290"
	R1/4	<a href="#">PQ-ME08M2</a>	0.880"	0.580"		
	R3/8	<a href="#">PQ-ME08M3</a>				
3/8"	1/8" NPT	<a href="#">PQ-ME12P</a>			11/16"	1.350"
	1/4" NPT	<a href="#">PQ-ME12Q</a>	1.100"	0.720"	11/16"	1.470"
	3/8" NPT	<a href="#">PQ-ME12W</a>			11/16"	1.500"
	1/2" NPT	<a href="#">PQ-ME12Z</a>			7/8"	1.600"
1/2"	1/4" NPT	<a href="#">PQ-ME16Q</a>				1.550"
	3/8" NPT	<a href="#">PQ-ME16W</a>	1.160"	0.850"	7/8"	1.580"
	1/2" NPT	<a href="#">PQ-ME16Z</a>				1.670"

\* Fittings have a green release button.  
 Note: Fittings with pipe thread NPT, R1/8, R1/4 and R3/8 are supplied with pre-applied sealant.

## Female Elbow

(5/pack)

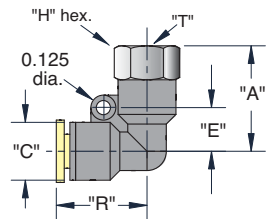

Tubing	Thread "T"	Part No.	"A"	"C"	"H" Hex.	"R"
1/8"	#10-32	<a href="#">PQ-FE04N</a>	0.830"	0.410"	7/16"	0.720"
	1/8" NPT	<a href="#">PQ-FE04P</a>	0.950"			
5/32"	#10-32	<a href="#">PQ-FE05N</a>	0.850"	0.410"	7/16"	0.722"
	1/8" NPT	<a href="#">PQ-FE05P</a>	0.990"			
	1/4" NPT	<a href="#">PQ-FE05Q</a>	0.980"			
1/4"	#10-32	<a href="#">PQ-FE08N</a>	0.940"	0.524"	7/16"	0.840"
	1/8" NPT	<a href="#">PQ-FE08P</a>	1.030"			
5/16"	1/4" NPT	<a href="#">PQ-FE08Q</a>	1.190"	0.580"	9/16"	0.900"
	1/8" NPT	<a href="#">PQ-FE10P</a>	1.120"			
3/8"	1/4" NPT	<a href="#">PQ-FE10Q</a>	1.220"	0.720"	11/16"	1.100"
	3/8" NPT	<a href="#">PQ-FE12Q</a>	1.390"			
		<a href="#">PQ-FE12W</a>	1.420"		7/8"	

## Extended Elbow

(5/pack)

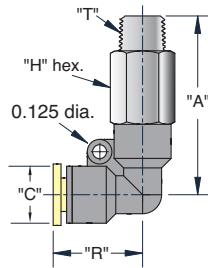

Tubing	Thread "T"	Part No.	"A"	"C"	"H" Hex.	"R"	
5/32"	#10-32	<a href="#">PQ-EE05N</a>	0.722"	0.410"	7/16"	1.360"	
	1/8" NPT	<a href="#">PQ-EE05P</a>					1.480"
1/4"	1/8" NPT	<a href="#">PQ-EE08P</a>	0.840"	0.524"	9/16"	1.640"	
	1/4" NPT	<a href="#">PQ-EE08Q</a>					1.820"
	1/2" NPT	<a href="#">PQ-EE08W</a>					1.940"
5/16"	1/8" NPT	<a href="#">PQ-EE10P</a>	0.900"	0.580"	9/16"	1.810"	
	1/4" NPT	<a href="#">PQ-EE10Q</a>					1.900"
	3/8" NPT	<a href="#">PQ-EE10W</a>					2.010"
	1/4" NPT	<a href="#">PQ-EE12Q</a>					2.170"
3/8"	3/8" NPT	<a href="#">PQ-EE12W</a>	1.100"	0.720"	11/16"	2.170"	
	1/2" NPT	<a href="#">PQ-EE12Z</a>					2.560"
1/2"	3/8" NPT	<a href="#">PQ-EE16W</a>	1.160"	0.850"	11/16"	2.470"	
	1/2" NPT	<a href="#">PQ-EE16Z</a>					2.600"

## Universal Elbow

(5/pack)

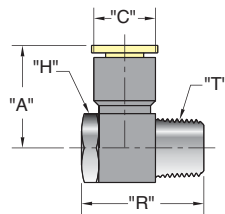

Tubing	Thread "T"	Part No.	"A"	"C"	"R"	"H" Hex.	
5/32"	#10-32	<a href="#">PQ-UE05N</a>	0.820"	0.410"	0.790"	5/16"	
	1/8" NPT	<a href="#">PQ-UE05P</a>					1.020"
4 mm*	M5 x 0.8	<a href="#">PQ-UE04M5</a>	0.831"	0.410"	0.790"	8 mm	
	R1/8	<a href="#">PQ-UE04MR</a>					0.921"
	R1/8	<a href="#">PQ-UE06M5</a>					0.953"
6 mm*	M5 x 0.8	<a href="#">PQ-UE06M5</a>	0.976"	0.524"	0.790"	12 mm	
	R1/8	<a href="#">PQ-UE06MR</a>					0.970"
	R1/4	<a href="#">PQ-UE06M2</a>					1.059"
1/4"	#10-32	<a href="#">PQ-UE08N</a>	0.940"	0.524"	0.790"	1/2"	
	1/8" NPT	<a href="#">PQ-UE08P</a>					1.020"
	1/4" NPT	<a href="#">PQ-UE08Q</a>					1.150"
5/16"	1/8" NPT	<a href="#">PQ-UE10P</a>	1.120"	0.580"	1.020"	9/16"	
	1/4" NPT	<a href="#">PQ-UE10Q</a>					1.150"
	3/8" NPT	<a href="#">PQ-UE10W</a>					1.430"
	R1/8	<a href="#">PQ-UE08MR</a>					1.000"
8 mm*	R1/4	<a href="#">PQ-UE08M2</a>	1.120"	0.580"	1.140"	14 mm	
	R3/8	<a href="#">PQ-UE08M3</a>					1.410"
	1/4" NPT	<a href="#">PQ-UE12Q</a>					1.180"
3/8"	1/4" NPT	<a href="#">PQ-UE12W</a>	1.320"	0.720"	1.430"	11/16"	
	3/8" NPT	<a href="#">PQ-UE12W</a>					

## Y Connector

(5/pack)

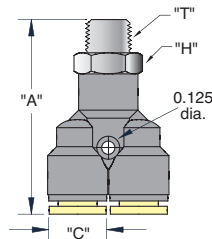

Tubing	Thread "T"	Part No.	"A"	"C"	"H" Hex.	
1/8"	#10-32	<a href="#">PQ-YC04N</a>	1.630"	0.410"	7/16"	
	1/8" NPT	<a href="#">PQ-YC04P</a>				1.660"
5/32"	#10-32	<a href="#">PQ-YC05N</a>	1.630"	0.410"	7/16"	
	1/8" NPT	<a href="#">PQ-YC05P</a>				1.660"
1/4"	#10-32	<a href="#">PQ-YC08N</a>	1.690"	0.524"	1/2"	
	1/8" NPT	<a href="#">PQ-YC08P</a>				1.770"
	1/4" NPT	<a href="#">PQ-YC08Q</a>				1.830"
5/16"	1/8" NPT	<a href="#">PQ-YC10P</a>	1.830"	0.580"	9/16"	
	1/4" NPT	<a href="#">PQ-YC10Q</a>				1.900"
3/8"	1/4" NPT	<a href="#">PQ-YC12Q</a>	2.340"	0.720"	11/16"	
	3/8" NPT	<a href="#">PQ-YC12W</a>				2.400"
1/2"	3/8" NPT	<a href="#">PQ-YC16W</a>	2.500"	0.850"	7/8"	
	1/2" NPT	<a href="#">PQ-YC16Z</a>				2.600"

\* Fittings have a green release button.

Note: Fittings with pipe thread NPT, R1/8, R1/4 and R3/8 are supplied with pre-applied sealant.

## Male Angle Connector

(10/pack)

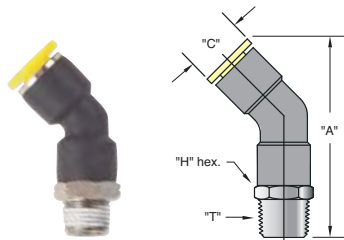

Tubing	Thread "T"	Part No.	"H" Hex.	"A"	"C"
1/8"	#10-32 1/8" NPT	<a href="#">PQ-MA04N</a> <a href="#">PQ-MA04P</a>	7/16"	1.454" 1.474"	0.410"
5/32"	#10-32 1/8" NPT	<a href="#">PQ-MA05N</a> <a href="#">PQ-MA05P</a>	7/16"	1.454" 1.474"	0.410"
4 mm*	M5 x 0.8 R1/8	<a href="#">PQ-MA04M5</a> <a href="#">PQ-MA04MR</a>	10 mm	1.454" 1.474"	0.410"
6 mm*	M5 x 0.8 R1/8 R1/4	<a href="#">PQ-MA06M5</a> <a href="#">PQ-MA06MR</a> <a href="#">PQ-MA06M2</a>	12 mm 10 mm 14 mm	1.556" 1.556" 1.616"	0.520"
1/4"	#10-32 1/8" NPT 1/4" NPT 3/8" NPT	<a href="#">PQ-MA08N</a> <a href="#">PQ-MA08P</a> <a href="#">PQ-MA08Q</a> <a href="#">PQ-MA08W</a>	1/2" 1/2" 9/16" 11/16"	1.620" 1.620" 1.682" 1.722"	0.520"
5/16"	1/8" NPT 1/4" NPT	<a href="#">PQ-MA10P</a> <a href="#">PQ-MA10Q</a>	9/16"	1.800"	0.580"
3/8"	1/8" NPT 1/4" NPT 3/8" NPT	<a href="#">PQ-MA12P</a> <a href="#">PQ-MA12Q</a> <a href="#">PQ-MA12W</a>	11/16"	1.823" 1.923" 1.943"	0.720"
1/2"	1/4" NPT 3/8" NPT 1/2" NPT	<a href="#">PQ-MA16Q</a> <a href="#">PQ-MA16W</a> <a href="#">PQ-MA16Z</a>	7/8"	1.965" 2.125" 2.195"	0.830"

## Stack Elbow

(5/pack)

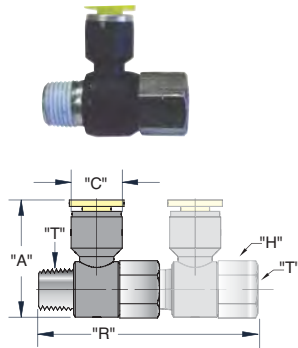

Two fittings shown stacked

Tubing	Thread "T"	Part No.	"A"	"C"	"R"	"H" Hex.
5/32"	#10-32 1/8" NPT	<a href="#">PQ-SE05N</a> <a href="#">PQ-SE05P</a>	0.980" 1.095"	0.410"	1.435"	5/16" 5/16"
1/4"	#10-32 1/8" NPT 1/4" NPT	<a href="#">PQ-SE08N</a> <a href="#">PQ-SE08P</a> <a href="#">PQ-SE08Q</a>	1.165" 1.200" 1.365"	0.524"	2.250" 2.250" 2.600"	1/2" 1/2" 11/16"
5/16"	1/4" NPT 3/8" NPT	<a href="#">PQ-SE10Q</a> <a href="#">PQ-SE10W</a>	1.425" 1.570"	0.580"	2.600" 2.900"	11/16" 3/4"
3/8"	1/4" NPT 3/8" NPT	<a href="#">PQ-SE12Q</a> <a href="#">PQ-SE12W</a>	1.625" 1.690"	0.720"	2.530" 2.970"	11/16" 3/4"
1/2"	3/8" NPT 1/2" NPT	<a href="#">PQ-SE16W</a> <a href="#">PQ-SE16Z</a>	1.740" 1.950"	0.850"	2.970" 3.160"	3/4" 1"

## Manifold Mount

(5/pack)

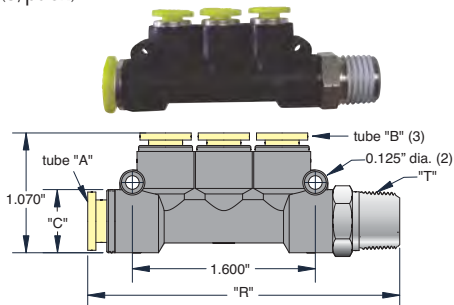

Tube "A"	Tube "B"	Thread "T"	Part No.	"C"	"R"
1/4"	5/32"	1/8" NPT	<a href="#">PQ-MM0805P</a>	0.524"	2.665"
5/16"	1/4"	1/4" NPT	<a href="#">PQ-MM1008Q</a>	0.580"	2.820"

\* Fittings have a green release button.

Note: Fittings with pipe thread NPT, R1/8, R1/4 and R3/8 are supplied with pre-applied sealant.



## Bulkhead Connector

(5/pack)

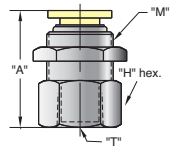

Tube	Thread "T"	Part No.	"A"	Thread "M"	"H" Hex.
1/8"	1/8" NPT	<a href="#">PQ-BC04P</a>	1.052"	M12x1	9/16"
5/32"	1/8" NPT	<a href="#">PQ-BC05P</a>	1.052"	M12x1	9/16"
4 mm*	R1/8	<a href="#">PQ-BC04MR</a>	1.052"	M12x1	14 mm
6 mm*	R1/8	<a href="#">PQ-BC06MR</a>	1.080"	M14x1	17 mm
	R1/4	<a href="#">PQ-BC06M2</a>	1.150"		
1/4"	1/8" NPT	<a href="#">PQ-BC08P</a>	1.084"	M14x1	11/16"
	1/4" NPT	<a href="#">PQ-BC08Q</a>	1.209"		
5/16"	1/8" NPT	<a href="#">PQ-BC10P</a>	1.150"	M16x1	11/16"
	1/4" NPT	<a href="#">PQ-BC10Q</a>	1.195"		
8 mm*	R1/8	<a href="#">PQ-BC08MR</a>	1.125"	M16x1	17 mm
	R1/4	<a href="#">PQ-BC08M2</a>	1.170"		
3/8"	1/4" NPT	<a href="#">PQ-BC12Q</a>	1.400"	M20x1	7/8"
	3/8" NPT	<a href="#">PQ-BC12W</a>	1.415"		
1/2"	1/2" NPT	<a href="#">PQ-BC16Z</a>	1.525"	M22x1	1"

## Bulkhead Union

(5/pack)

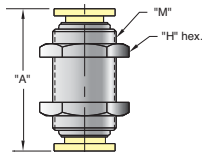

Tube	Part No.	"A"	Thread "M"	"H" Hex.
1/8"	<a href="#">PQ-BU04</a>	0.415"	M12 x 1	14 mm
5/32"	<a href="#">PQ-BU05</a>	1.370"	M12 x 1	5/8"
6 mm*	<a href="#">PQ-BU06M</a>	1.390"	M14 x 1	17 mm
1/4"	<a href="#">PQ-BU08</a>	1.421"	M14 x 1	3/4"
5/16"	<a href="#">PQ-BU10</a>	1.610"	M16 x 1	3/4"
3/8"	<a href="#">PQ-BU12</a>	1.723"	M20 x 1	15/16"
1/2"	<a href="#">PQ-BU16</a>	1.770"	M22 x 1	1"

## Straight Union

(10/pack)

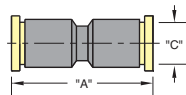

Tube	Part No.	"A"	"C"
1/8"	<a href="#">PQ-SU04</a>	1.240"	0.410"
5/32"	<a href="#">PQ-SU05</a>	1.239"	0.410"
6 mm*	<a href="#">PQ-SU06M</a>	1.500"	0.524"
1/4"	<a href="#">PQ-SU08</a>	1.500"	0.524"
5/16"	<a href="#">PQ-SU10</a>	1.540"	0.580"
3/8"	<a href="#">PQ-SU12</a>	1.851"	0.720"
1/2"	<a href="#">PQ-SU16</a>	1.810"	0.850"

## Elbow Union

(10/pack)

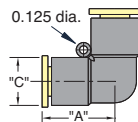

Tube	Part No.	"A"	"C"
1/8"	<a href="#">PQ-EU04</a>	0.710"	0.410"
5/32"	<a href="#">PQ-EU05</a>	0.722"	0.410"
6 mm*	<a href="#">PQ-EU06M</a>	0.830"	0.524"
1/4"	<a href="#">PQ-EU08</a>	0.840"	0.524"
5/16"	<a href="#">PQ-EU10</a>	0.880"	0.580"
3/8"	<a href="#">PQ-EU12</a>	1.100"	0.720"
1/2"	<a href="#">PQ-EU16</a>	1.130"	0.850"

## Tee Union

(10/pack)

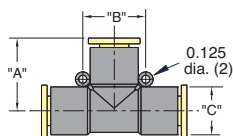

Tube	Part No.	"A"	"B"	"C"
1/8"	<a href="#">PQ-TU04</a>	0.710"	0.656"	0.410"
5/32"	<a href="#">PQ-TU05</a>	0.722"	0.656"	0.410"
6 mm*	<a href="#">PQ-TU06M</a>	0.830"	0.740"	0.524"
1/4"	<a href="#">PQ-TU08</a>	0.840"	0.740"	0.524"
5/16"	<a href="#">PQ-TU10</a>	0.880"	0.800"	0.580"
3/8"	<a href="#">PQ-TU12</a>	1.100"	0.944"	0.720"
1/2"	<a href="#">PQ-TU16</a>	1.130"	1.120"	0.850"

Note:  
Fittings with  
pipe thread  
NPT, R1/8,  
R1/4 and  
R3/8 are  
supplied  
with pre-  
applied  
sealant.

## Cross Union

(5/pack)

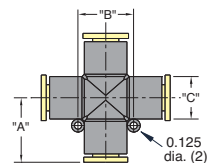

Tube	Part No.	"A"	"B"	"C"
1/8"	<a href="#">PQ-CU04</a>	0.710"	0.560"	0.410"
5/32"	<a href="#">PQ-CU05</a>	0.722"	0.656"	0.410"
6 mm*	<a href="#">PQ-CU06M</a>	0.830"	0.740"	0.524"
1/4"	<a href="#">PQ-CU08</a>	0.840"	0.740"	0.524"
5/16"	<a href="#">PQ-CU10</a>	0.880"	0.800"	0.580"
3/8"	<a href="#">PQ-CU12</a>	1.100"	0.944"	0.720"

## Manifold Union

(5/pack)

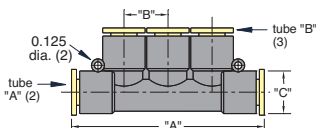

Tube "A"	Tube "B"	Part No.	"A"	"B"	"C"
5/32"	1/8"	<a href="#">PQ-MU0504</a>	2.312"	0.500"	0.560"
6 mm*	5/32"	<a href="#">PQ-MU06M05</a>	2.435"	0.531"	0.524"
1/4"	5/32"	<a href="#">PQ-MU0805</a>	2.435"	0.531"	0.524"
5/16"	1/4"	<a href="#">PQ-MU1008</a>	2.435"	0.580"	0.580"
3/8"	1/4"	<a href="#">PQ-MU1208</a>	2.312"	0.562"	0.725"

\* Fittings have a green release button

## Reduced Union

(10/pack)

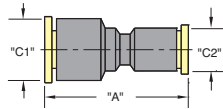

Tubing	Part No.	"A"	"C1"	"C2"
5/32"-1/8"	<a href="#">PQ-RU0504</a>	1.230"	0.410"	0.410"
6 mm*-5/32"	<a href="#">PQ-RU06M05</a>	1.367"	0.524"	0.410"
1/4"-1/8"	<a href="#">PQ-RU0804</a>	1.367"	0.524"	0.410"
5/16"-1/4"	<a href="#">PQ-RU1008</a>	1.550"	0.580"	0.524"
3/8"-1/4"	<a href="#">PQ-RU1208</a>	1.666"	0.720"	0.524"
1/2"-3/8"	<a href="#">PQ-RU1612</a>	1.810"	0.850"	0.720"

## Y Union

(5/pack)

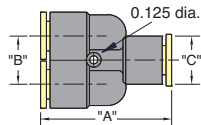

Tubing	Part No.	"A"	"B"	"C"
1/8"	<a href="#">PQ-YU04</a>	1.340"	0.415"	0.410"
5/32"	<a href="#">PQ-YU05</a>	1.318"	0.517"	0.410"
6 mm*	<a href="#">PQ-YU06M</a>	1.495"	0.531"	0.524"
1/4"	<a href="#">PQ-YU08</a>	1.495"	0.531"	0.524"
5/16"	<a href="#">PQ-YU10</a>	1.495"	0.590"	0.580"
3/8"	<a href="#">PQ-YU12</a>	2.017"	0.720"	0.720"
1/2"	<a href="#">PQ-YU16</a>	2.070"	0.840"	0.840"

## Reduced Branch

(5/pack)

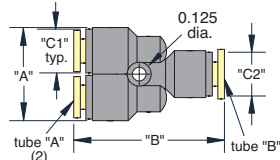

Tube "A"	Tube "B"	Part No.	"A"	"B"	"C1"	"C2"
1/8"	5/32"	<a href="#">PQ-RB0504</a>	0.830"	1.340"	0.420"	0.410"
5/32"	1/4"	<a href="#">PQ-RB0805</a>	0.830"	1.390"	0.410"	0.524"
1/4"	5/16"	<a href="#">PQ-RB1008</a>	1.025"	1.670"	0.524"	0.580"
1/4"	3/8"	<a href="#">PQ-RB1208</a>	1.025"	1.780"	0.524"	0.720"
3/8"	1/2"	<a href="#">PQ-RB1612</a>	1.420"	2.050"	0.720"	0.850"

## Tee Reducer

(5/pack)

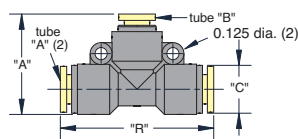

Tube "A"	Tube "B"	Part No.	"A"	"C"	"R"
5/32"	1/8"	<a href="#">PQ-TR0504</a>	0.910"	0.410"	1.385"
1/4"	5/32"	<a href="#">PQ-TR0805</a>	1.050"	0.524"	1.570"
5/16"	1/4"	<a href="#">PQ-TR1008</a>	1.170"	0.580"	1.835"
3/8"	1/4"	<a href="#">PQ-TR1208</a>	1.380"	0.720"	2.160"
1/2"	3/8"	<a href="#">PQ-TR1612</a>	1.600"	0.850"	2.240"

## Elbow Reducer

(5/pack)

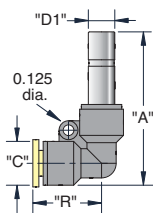

Tubing	Part No.	"A"	"C"	"D1"	"R"
1/8"	<a href="#">PQ-ER0405</a>	1.480"	0.420"	5/32"	0.710"
5/32"	<a href="#">PQ-ER0508</a>	1.640"	0.410"	1/4"	0.722"
1/4"	<a href="#">PQ-ER0810</a>	1.765"	0.524"	5/16"	0.840"
5/16"	<a href="#">PQ-ER1012</a>	2.020"	0.580"	3/8"	0.880"
3/8"	<a href="#">PQ-ER1216</a>	2.260"	0.720"	1/2"	1.100"

## Plug-In Elbow

(5/pack)

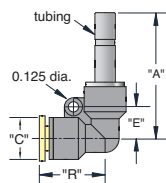

Tubing	Part No.	"A"	"C"	"E"	"R"
1/8"	<a href="#">PQ-PE04</a>	1.290"	0.410"	0.328"	0.722"
5/32"	<a href="#">PQ-PE05</a>	1.290"	0.410"	0.328"	0.722"
1/4"	<a href="#">PQ-PE08</a>	1.550"	0.524"	0.370"	0.840"
5/16"	<a href="#">PQ-PE10</a>	1.600"	0.580"	0.430"	0.900"
3/8"	<a href="#">PQ-PE12</a>	1.850"	0.720"	0.472"	1.100"
1/2"	<a href="#">PQ-PE16</a>	1.940"	0.850"	0.570"	1.160"

## Tube Reducer (Stem)

(10/pack)

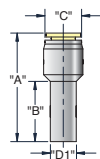

Tubing	Part No.	"A"	"B"	"C"	"D1"
1/8"	<a href="#">PQ-TRS0405</a>	1.320"	0.690"	0.410"	5/32"
5/32"	<a href="#">PQ-TRS0508</a>	1.400"	0.810"	0.524"	1/4"
1/4"	<a href="#">PQ-TRS0810</a>	1.480"	0.850"	0.580"	5/16"
1/4"	<a href="#">PQ-TRS0812</a>	1.610"	0.990"	0.720"	3/8"
3/8"	<a href="#">PQ-TRS1216</a>	1.730"	0.990"	0.850"	1/2"

\* Fittings have a green release button.

Note: Fittings with pipe thread NPT, R1/8, R1/4 and R3/8 are supplied with pre-applied sealant.

## Stem Reducer

(10/pack)

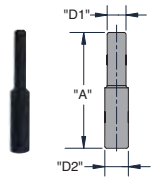

Tubing	Part No.	"A"	"D1"	"D2"
5/32"	<a href="#">PQ-SR0508</a>	1.417"	5/32"	1/4"
1/4"	<a href="#">PQ-SR0810</a>	1.535"	1/4"	5/16"
5/16"	<a href="#">PQ-SR1012</a>	1.811"	5/16"	3/8"
3/8"	<a href="#">PQ-SR1216</a>	2.126"	3/8"	1/2"

## Stem Coupler

(10/pack)

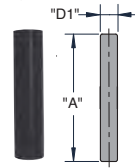

Tubing	Part No.	"A"	"D1"
5/32"	<a href="#">PQ-SC05</a>	1.378"	5/32"
1/4"	<a href="#">PQ-SC08</a>	1.457"	1/4"

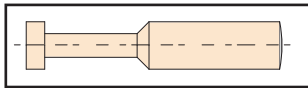

## Push-Quick Plugs

Clippard offers a variety of Push-Quick Plugs in sizes to fit 1/8" through 3/8" O.D. tubing.

These plastic plugs may be used to plug the port of a Push-Quick Fitting for later use. Used as a temporary plug,

they may later be removed and tubing inserted to connect to an additional line of a circuit.

Part No.	Description	Part No.	Description
<a href="#">PQ-PG04</a>	1/8" O.D. Tube	<a href="#">PQ-PG08</a>	1/4" O.D. Tube
<a href="#">PQ-PG05</a>	5/32" O.D. Tube	<a href="#">PQ-PG10</a>	5/16" O.D. Tube
<a href="#">PQ-PG06M</a>	6 mm O.D. Tube	<a href="#">PQ-PG12</a>	3/8" O.D. Tube

## Push-Quick Fitting Adapters

Clippard offers a variety of accessories that are designed for use with Push-Quick Fittings. These include special #10-32 threaded adapters in both male (p/n 11674) and female (p/n 11675) thread configurations and adapters that can be used to plug a Push-Quick fitting.

The threaded adapters insert into Push-Quick Fittings and provide either a male or female thread that can be used to mount any Clippard product with a #10-32 threaded inlet. This allows the direct attachment of the product to a Push-Quick Fitting without hoses or additional fittings.

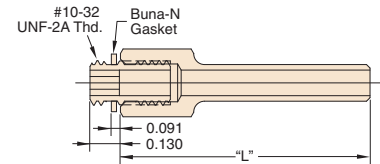

Part No.	"L"	Tube Size
<a href="#">11674-05</a>	1.063"	5/32" OD
<a href="#">11674-08</a>	1.031"	1/4" OD
<a href="#">11674-12</a>	1.218"	3/8" OD

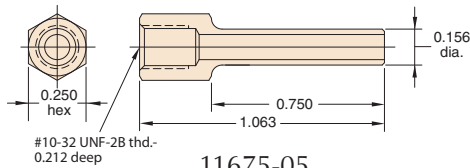

[11675-05](#)  
5/32" O.D. Tube

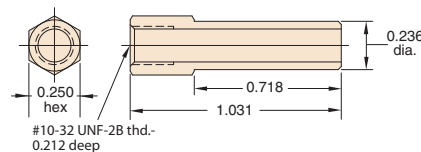

[11675-08](#)  
1/4" O.D. Tube

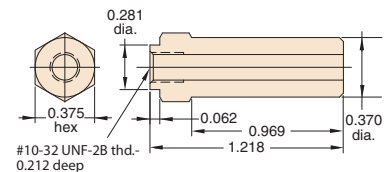

[11675-12](#)  
3/8" O.D. Tube

**Figure 1** shows an MAV-3 3-Way Valve connected to a PQ-RT05P Run Tee using a 11674-05 Adapter. In this example, the Run Tee is connected to a 1/8" NPT supply pipe.

**Figure 2** shows an IND-1M-WH Pressure Indicator connected to a PQ-TU08 Tee Union using a 11675-08 Adapter. If one of the branches of a Push-Quick Fitting is to be used as a temporary pressure gauge port, the PQ-PGXX series of Plugs can be used when the gauge is not in place. Plugs may also be used if Push-Quick Fitting branches are intended for future additions to the circuit, but have no current need.

**Figure 3** shows a PQ-CU Cross Union with one branch plugged with a PQ-PG08 Plug.

MAV-3



**Figure 1**

[11674](#)

Run Tee



IND-1M-WH



**Figure 2**

[11675](#)

Tee Union



PQ-PGXX



**Figure 3**

Cross Union





Minimatic barb fittings provide a flexible, easy alternative to ferrule and push-to-connect design fittings.

Clippard Minimatic barb fittings are designed to be used with Clippard urethane hose. The flexibility and strength of urethane hose and the compact design of the fittings are ideal for pneumatic applications where convenience and size are considerations. The Minimatic barb fitting used with Clippard urethane hose will provide a leak free connection that will hold well beyond the working pressure of the hose without the need for additional clamps.

Minimatic barb fittings are available in a wide variety of configurations in a number of styles including tee, connectors, crosses, swivel, and universal. Barb sizes can be mixed on the same fitting for applications requiring multiple tubing sizes. The electroless nickel plating of Minimatic barb fittings provides corrosion resistance in applications involving high moisture, while enabling the fittings to retain their original, lustrous appearance. Nitrile gasket included with #10-32 threads except when ordered in bulk.

## Features

- Miniature size provides low profile
- Multiple configurations for every need
- Brass or Brass Electroless nickel plating
- Available with many hose barb sizes
- Available with #10-32 thread and 1/8" NPT
- Holds to the burst pressure of polyurethane hose



## Miniature Pneumatic Fittings Poster

Clippard's full-color fittings poster displays hundreds of available fittings including Push-Quick, Barb, Brass, Quick-Connect and more. Also included is an extensive variety of miniature hose and tubing from copper and nylon to flexible polyurethane, vinyl and Nitrile. Sizes include 1/8" c 1/4", 5/32", 6 mm, 8 mm, 3/8" and 1/2" OD in various styles. Call or visit [www.clippard.com](http://www.clippard.com) to request a copy.



## Single-Barb Fittings

- Allow for easier assembly onto tubing
- Provide less leakage potential and increased pressure performance
- Reduce the need to constantly tighten the assembly
- Provide a single sharp edge allowing the barb to catch onto the tubing for a leak-free connection
- Require less clamp pressure
- Allow tubing to "relax" to its original size which is essential to the assembly and pressure of the connection.

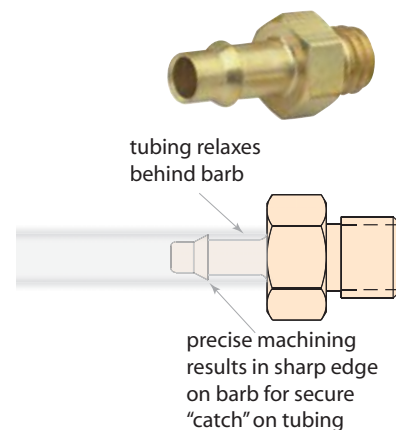

All fittings are brass unless otherwise noted, i.e. ENP (Electroless Nickel-Plated)

## #3-56 to Barb Connectors

### #3-56 Male to 1/16" Barb

(10/pack)

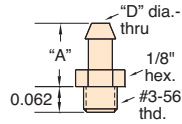

Barb (ID)	Order No.	"A"	"D" Dia.
1/16"	<a href="#">11750-2</a>	0.187"	0.046"

## #10-32 to Barb Connectors

### #10-32 Male to Single Barb

(11752- 10/pack)

(CT\_ 5/pack)

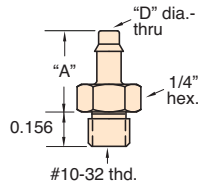

Barb (ID)	Order No.	"A"	"D" Dia.	Material
1/16"	11752-5*	0.312"	0.052"	Brass
3/32"	<a href="#">11752-8*</a>	0.367"	0.073"	Brass
1/8"	11752-4*	0.406"	0.109"	Brass
1/16"	<a href="#">CT2**</a>	0.328"	0.052"	ENP Brass
3/32"	<a href="#">CT3**</a>	0.367"	0.073"	ENP Brass
1/8"	<a href="#">CT4**</a>	0.406"	0.109"	ENP Brass

\* Nitrile gasket furnished in pack quantity only

\*\* Gasket pre-installed

### #10-32 Male to Multi Barb

(10/pack)

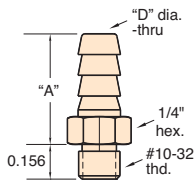

Barb (ID)	Order No.	"A"	"D" Dia.
1/16"	11752-2	0.437"	0.052"
1/8"	<a href="#">11752-3</a>	0.500"	0.109"
1/8"	<a href="#">11752-1</a>	0.656"	0.090"

Nitrile gasket furnished in pack quantity only

### #10-32 Male with Captivated O-Rings to Barb, 1/4" Hex.

(10/pack)

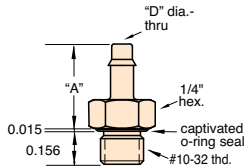

Barb (ID)	Order No.	"A"	"D" Dia.
1/16"	11792-5	0.313"	0.052"
3/32"	<a href="#">11792-8</a>	0.352"	0.073"
1/8"	<a href="#">11792-4</a>	0.391"	0.109"

Nitrile o-ring furnished installed



### ENP #10-32 Male with Captivated O-Rings to Barb, 5/16" Hex.

(10/pack)

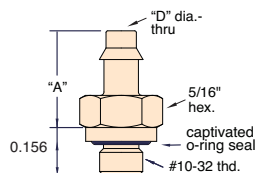

Barb (ID)	Order No.	"A"	"D" Dia.
1/16"	<a href="#">11782-5-ENP</a>	0.481"	0.055"
1/8"	<a href="#">11782-4-ENP</a>	0.512"	0.109"

Nitrile o-ring furnished installed

### #10-32 Male Flush Fitting to Barb

(10/pack)

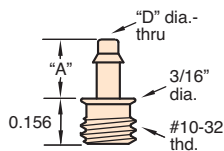

Barb (ID)	Order No.	"A"	"D" Dia.
1/16"	<a href="#">12841</a>	0.203"	0.052"
3/32"	<a href="#">12843</a>	0.242"	0.073"
1/8"	<a href="#">12842</a>	0.325"	0.104"

Gasket not required; thread sealant required. Tighten by hand for flush mounting in #10-32 threaded holes.





# MINIMATIC® BARB CONNECTORS

All fittings are brass unless otherwise noted, i.e. ENP (Electroless Nickel-Plated)

## ENP #10-32 Male to Barb Swivel

(5/pack)

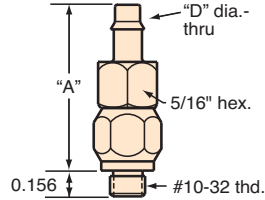

Barb (ID)	Order No.	"A"	#D" Dia.
3/32"	<a href="#">ST3</a>	0.821"	0.052"
1/8"	<a href="#">ST4</a>	0.891"	0.109"

Gasket included, not installed

## #10-32 Male to 1/8" I.D. Barb Swivel

(5/pack)

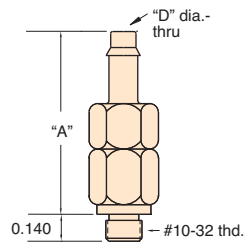

Barb (ID)	Order No.	"A"	"D" Dia.
1/8"	<a href="#">15045</a>	0.762"	0.109"

Not to be used as a constant rotation junction

**TIP** Most Clippard #10-32 threaded fittings require no more than 9 inch-pounds of torque to seal. We recommend that this force not be exceeded.

## ENP #10-32 Female to Barb

(5/pack)

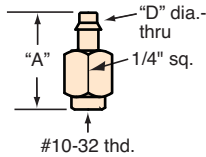

Barb (ID)	Order No.	"A"	"D" Dia.
1/16"	<a href="#">CF2</a>	0.640"	0.052"
3/32"	<a href="#">CF3</a>	0.640"	0.073"
1/8"	<a href="#">CF4</a>	0.718"	0.109"

## ENP #10-32 Female to Barb Swivel

(5/pack)

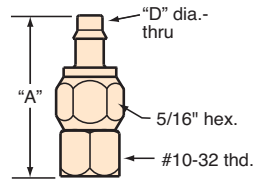

Barb (ID)	Order No.	"A"	"D" Dia.
3/32"	<a href="#">S3F</a>	0.821"	0.052"
1/8"	<a href="#">S4F</a>	0.871"	0.109"

## Barb to Barb Connectors

### ENP Barb to Barb

(5/pack)

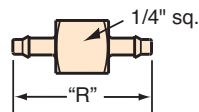

Barb (ID)	Barb (ID)	Order No.	"R"
1/16"	1/16"	<a href="#">C22</a>	0.656"
1/16"	3/32"	<a href="#">C32</a>	0.684"
1/16"	1/8"	<a href="#">C42</a>	0.734"
3/32"	3/32"	<a href="#">C33</a>	0.712"
3/32"	1/8"	<a href="#">C43</a>	0.762"
1/8"	1/8"	<a href="#">C44</a>	0.812"

### ENP Barb to Barb Swivel

(5/pack)

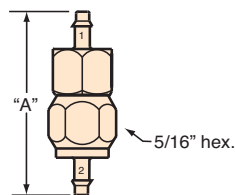

Barb (ID) 1	Barb (ID) 2	Order No.	"A"
3/32"	3/32"	<a href="#">S33</a>	1.052"
1/8"	1/8"	<a href="#">S44</a>	1.183"



All fittings are brass unless otherwise noted, i.e. ENP (Electroless Nickel-Plated)

## 1/16" Barb to Male NPT

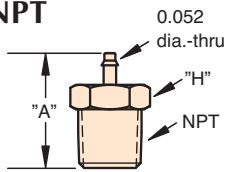

NPT	Order No.	"A"	"H" Hex.	Pkg. Qty.
1/16"	<a href="#">1CJ2</a>	0.490"	5/16"	10
1/8"	<a href="#">2CP2</a>	0.740"	7/16"	10
1/4"	<a href="#">4CQ2</a>	0.770"	9/16"	1
3/8"	<a href="#">6CW2</a>	0.890"	11/16"	1
1/2"	<a href="#">8CZ2</a>	1.020"	13/16"	1

## 3/32" Barb to Male NPT

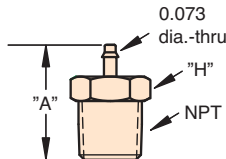

NPT	Order No.	"A"	"H" Hex.	Pkg. Qty.
1/16"	<a href="#">1CJ3</a>	0.710"	5/16"	10
1/8"	<a href="#">2CP3</a>	0.773"	7/16"	10
1/4"	<a href="#">4CQ3</a>	0.804"	9/16"	1
3/8"	<a href="#">6CW3</a>	0.929"	11/16"	1
1/2"	<a href="#">8CZ3</a>	1.054"	13/16"	1

## 1/8" Barb to Male NPT

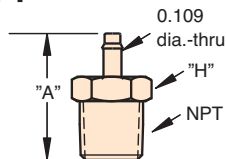

NPT	Order No.	"A"	"H" Hex.	Pkg. Qty.
1/16"	<a href="#">1CJ4</a>	0.719"	5/16"	10
1/8"	<a href="#">2CP4</a>	0.860"	7/16"	10
1/4"	<a href="#">4CQ4</a>	0.890"	9/16"	1
3/8"	<a href="#">6CW4</a>	1.020"	11/16"	1
1/2"	<a href="#">8CZ4</a>	1.140"	13/16"	1

## 1/8" Barb to 1/8" Male NPT

(10/pack)

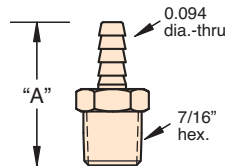

Barb (ID)	Order No.	"A"
1/8"	<a href="#">11924-1</a>	1.000"



## Barb to 1/8" Male NPT Swivel

(5/pack)

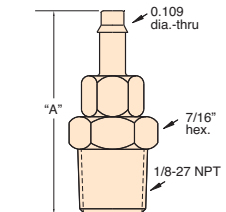

Barb (ID)	Order No.	"A"
1/8"	<a href="#">15055</a>	1.155"

*Nitrile o-ring furnished installed*

*Not to be used as a constant rotation junction*

## ENP 1/8" NPT Swivel

(5/pack)

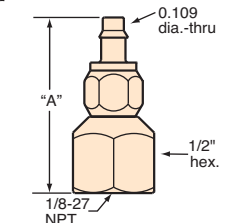

Barb (ID)	Order No.	"A"
1/8"	<a href="#">S4N</a>	1.103"

## 1/4" Barb to Male NPT Flush Fittings

(10/pack)

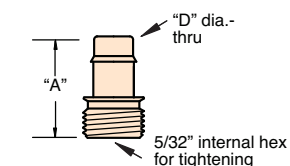

Barb (ID)	Order No.	"A"	NPT
1/8"	<a href="#">12844*</a>	0.625"	1/8"
1/4"	<a href="#">12845*</a>	0.625"	1/4"

*\* Requires thread sealant. Threads specifically designed to go flush into 1/8" or 1/4" NPT female port*

All fittings are ENP (Electroless Nickel-Plated)

## #10-32 Male to Barb

(5/pack)

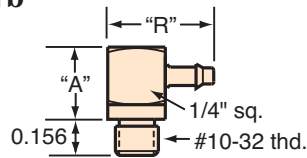

Barb (ID)	Order No.	"A"	"R"
1/16"	<a href="#">CT0-2</a>	0.312"	0.468"
3/32"	<a href="#">CT0-3</a>	0.312"	0.493"
1/8"	<a href="#">CT0-4</a>	0.312"	0.562"

Gasket included, not installed

## #10-32 Male to Barb Universal

(5/pack)

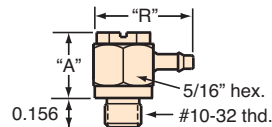

Barb (ID)	Order No.	"A"	"R"
1/16"	<a href="#">UT0-2</a>	0.344"	0.504"
3/32"	<a href="#">UT0-3</a>	0.344"	0.556"
1/8"	<a href="#">UT0-4</a>	0.344"	0.576"

Nitrile o-ring included

## #10-32 Female to Barb

(5/pack)

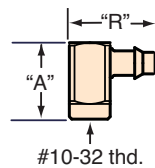

Barb (ID)	Order No.	"A"	"R"
1/16"	<a href="#">CF0-2</a>	0.468"	0.453"
3/32"	<a href="#">CF0-3</a>	0.468"	0.493"
1/8"	<a href="#">CF0-4</a>	0.468"	0.525"

## Universal #10-32

(5/pack)

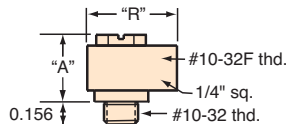

Order No.	"A"	"R"
<a href="#">UT0-F</a>	0.344"	0.500"

## #10-32 Male to Barb Swivel

(5/pack)

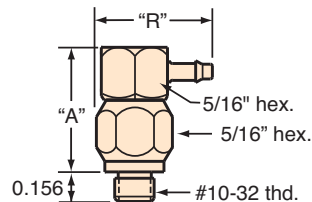

Barb (ID)	Order No.	"A"	"R"
1/16"	<a href="#">ST0-2</a>	0.578"	0.531"
3/32"	<a href="#">ST0-3</a>	0.578"	0.580"
1/8"	<a href="#">ST0-4</a>	0.578"	0.611"

Gasket included, not installed



## 1/8" NPT Male to Barb Swivel

(5/pack)

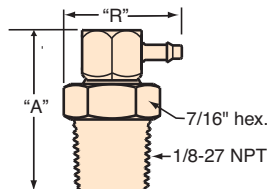

Barb (ID)	Order No.	"A"	"R"
1/16"	<a href="#">SP0-2</a>	0.843"	0.612"
3/32"	<a href="#">SP0-3</a>	0.843"	0.653"
1/8"	<a href="#">SP0-4</a>	0.843"	0.684"

## 1/8" Barb to Barb Swivel

(5/pack)

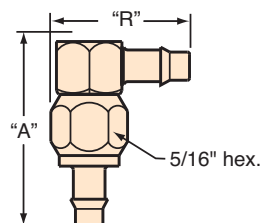

Barb (ID)	Order No.	"A"	"R"
1/8"	<a href="#">S40-4</a>	0.875"	0.656"

All fittings are ENP (Electroless Nickel-Plated)

## #10-32 Male to Barb

(5/pack)

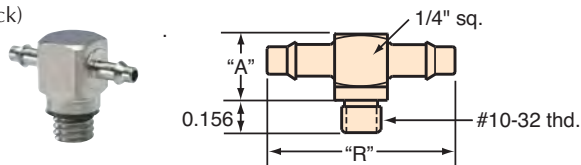

Barb (ID)	Barb (ID)	Order No.	"A"	"R"
1/16"	1/16"	<a href="#">TT0-202</a>	0.312"	0.670"
3/32"	3/32"	<a href="#">TT0-303</a>	0.312"	0.738"
1/8"	1/16"	<a href="#">TT0-402</a>	0.312"	0.748"
1/8"	1/8"	<a href="#">TT0-404</a>	0.312"	0.826"

Nitrile gasket included, not installed

## #10-32 Male Universal

(5/pack)

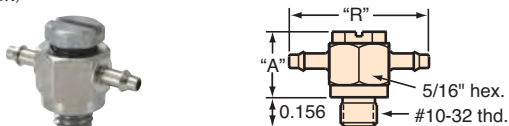

Barb (ID)	Barb (ID)	Order No.	"A"	"R"
1/16"	1/16"	<a href="#">UT0-2002</a>	0.344"	0.718"
1/16"	3/32"	<a href="#">UT0-3002</a>	0.344"	0.759"
1/16"	3/32"	<a href="#">UT0-3003</a>	0.344"	0.800"
1/8"	1/16"	<a href="#">UT0-4002</a>	0.344"	0.790"
1/8"	3/32"	<a href="#">UT0-4003</a>	0.344"	0.832"
1/8"	1/8"	<a href="#">UT0-4004</a>	0.344"	0.863"

Nitrile o-ring included

## Universal #10-32

(5/pack)

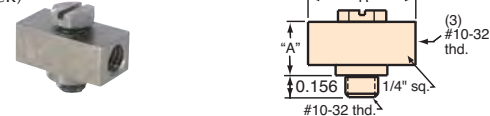

Order No.	"A"	"R"
<a href="#">UT0-FOF</a>	0.351"	0.625"



## #10-32 Male Swivel

(5/pack)

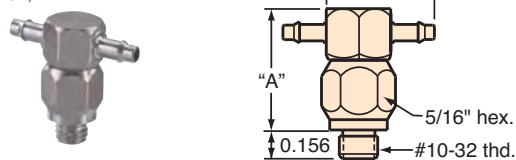

Barb (ID)	Barb (ID)	Order No.	"A"	"R"
1/16"	1/16"	<a href="#">ST0-2002</a>	0.578"	0.718"
3/32"	3/32"	<a href="#">ST0-3003</a>	0.578"	0.801"
1/8"	1/8"	<a href="#">ST0-4004</a>	0.578"	0.863"

Gasket included, not installed

## 1/8" NPT Male Swivel

(5/pack)

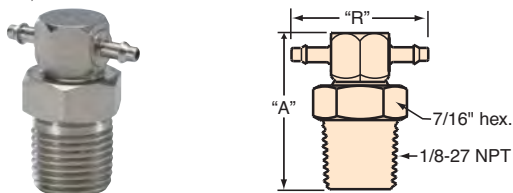

Barb (ID)	Barb (ID)	Order No.	"A"	"R"
1/16"	1/16"	<a href="#">SP0-2002</a>	0.843"	0.718"
3/32"	3/32"	<a href="#">SP0-3003</a>	0.843"	0.801"
1/8"	1/8"	<a href="#">SP0-4004</a>	0.843"	0.863"

## Barb to Barb

(5/pack)

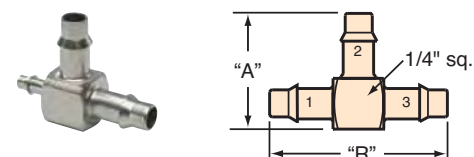

Barb 1 (ID)	Barb 2 (ID)	Barb 3 (ID)	Order No.	"A"	"R"
1/16"	1/16"	1/16"	<a href="#">T22-2</a>	0.671"	0.460"
1/16"	1/16"	1/8"	<a href="#">T42-2</a>	0.734"	0.460"
1/16"	3/32"	1/16"	<a href="#">T22-3</a>	0.656"	0.494"
1/16"	1/8"	1/16"	<a href="#">T22-4</a>	0.656"	0.538"
1/16"	1/8"	1/8"	<a href="#">T42-4</a>	0.734"	0.538"
3/32"	1/16"	3/32"	<a href="#">T33-2</a>	0.712"	0.460"
3/32"	3/32"	3/32"	<a href="#">T33-3</a>	0.712"	0.494"
3/32"	1/8"	3/32"	<a href="#">T33-4</a>	0.712"	0.538"
1/8"	1/16"	1/8"	<a href="#">T44-2</a>	0.812"	0.460"
1/8"	3/32"	1/8"	<a href="#">T44-3</a>	0.812"	0.494"
1/8"	1/8"	1/8"	<a href="#">T44-4</a>	0.812"	0.538"

## Barb to Barb Swivel

(5/pack)

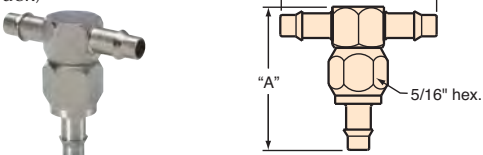

Barb (ID)	Order No.	"A"	"R"
1/8"	<a href="#">S40-4004</a>	0.871"	0.611"

All fittings are ENP (Electroless Nickel-Plated)

## #10-32 Male to Barb

(5/pack)

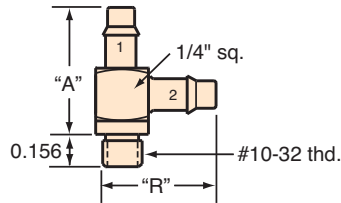

Barb 1 (ID)	Barb 2 (ID)	Order No.	"A"	"R"
1/16"	1/16"	<a href="#">TT2-2</a>	0.515"	0.460"
1/16"	1/8"	<a href="#">TT2-4</a>	0.500"	0.525"
3/32"	3/32"	<a href="#">TT3-3</a>	0.543"	0.493"
1/8"	1/16"	<a href="#">TT4-2</a>	0.593"	0.460"
1/8"	1/8"	<a href="#">TT4-4</a>	0.593"	0.538"

Nitrile gasket included, not installed

## #10-32 Male to Barb Swivel

(5/pack)

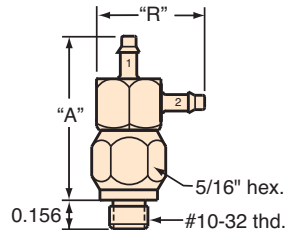

Barb 1 (ID)	Barb 2 (ID)	Order No.	"A"	"R"
1/16"	1/16"	<a href="#">ST2-2</a>	0.781"	0.516"
3/32"	3/32"	<a href="#">ST3-3</a>	0.821"	0.556"
1/8"	1/8"	<a href="#">ST4-4</a>	0.872"	0.556"

Gasket included, not installed



## Universal #10-32 to Barb

(5/pack)

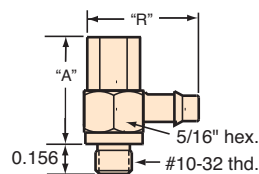

Barb (ID)	Order No.	"A"	"R"
1/16"	<a href="#">UTF-2</a>	0.562"	0.504"
3/32"	<a href="#">UTF-3</a>	0.562"	0.556"
1/8"	<a href="#">UTF-4</a>	0.562"	0.576"

Nitrile o-ring included

## Universal #10-32

(5/pack)

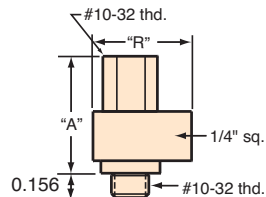

Order No.	"A"	"R"
<a href="#">UTF-F</a>	0.562"	0.500"

## 1/8" NPT Male to Barb

(5/pack)

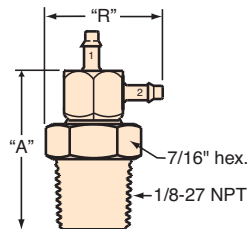

Barbs (ID)	Order No.	"A"	"R"
1/16"	<a href="#">SP2-2</a>	1.031"	0.625"
3/32"	<a href="#">SP3-3</a>	0.656"	1.062"
1/8"	<a href="#">SP4-4</a>	1.156"	0.718"

## Barb to Barb Swivel

(5/pack)

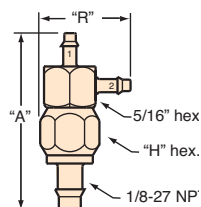

Barb 1 (ID)	Barb 2 (ID)	Order No.	"A"	"R"
1/16"	1/16"	<a href="#">S42-2</a>	1.074"	0.531"
1/8"	1/8"	<a href="#">S44-4</a>	1.183"	0.611"

All fittings are ENP (Electroless Nickel-Plated) unless otherwise noted

## #10-32 Male to Barb

(5/pack)

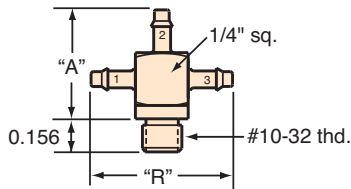

Barb 1 (ID)	Barb 2 (ID)	Barb 3 (ID)	Order No.	"A"	"R"
1/16"	1/16"	1/16"	<a href="#">XT2-202</a>	0.515"	0.670"
1/16"	1/8"	1/16"	<a href="#">XT4-202</a>	0.593"	0.670"
3/32"	3/32"	3/32"	<a href="#">XT3-303</a>	0.543"	0.736"
1/8"	1/16"	1/16"	<a href="#">XT2-402</a>	0.515"	0.748"
1/8"	1/16"	1/8"	<a href="#">XT2-404</a>	0.515"	0.826"
1/8"	1/8"	1/16"	<a href="#">XT4-402</a>	0.593"	0.748"
1/8"	1/8"	1/8"	<a href="#">XT4-404</a>	0.593"	0.826"

Nitrile gasket included, not installed

## Universal #10-32 to Barb

(5/pack)

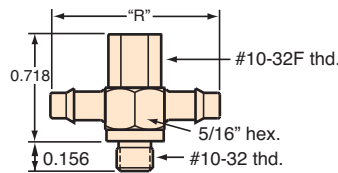

Barb	Barb	Order No.	"A"	"R"
1/16"	1/16"	<a href="#">UTF-2002</a>	0.562"	0.718"
3/32"	3/32"	<a href="#">UTF-3003</a>	0.562"	0.800"
1/8"	1/16"	<a href="#">UTF-4002</a>	0.562"	0.790"
1/8"	1/8"	<a href="#">UTF-4004</a>	0.562"	0.863"

Nitrile o-ring included

## Universal #10-32

(5/pack)

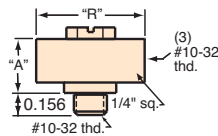

Order No.	"A"	"R"
<a href="#">UTF-FOE</a>	0.562"	0.625"

## Barb to Barb

(5/pack)

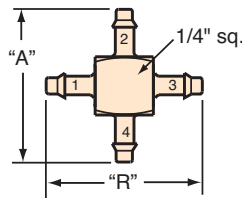

Barb 1	Barb 2	Barb 3	Barb 4	Order No.	"A"	"R"
1/16"	1/16"	1/16"	1/16"	<a href="#">X22-202</a>	0.656"	0.670"
1/16"	1/16"	1/16"	3/32"	<a href="#">X32-202</a>	0.684"	0.670"
1/16"	1/16"	1/16"	1/8"	<a href="#">X42-202</a>	0.734"	0.670"
1/16"	1/8"	1/16"	1/8"	<a href="#">X44-202</a>	0.812"	0.670"
1/16"	1/8"	1/8"	1/8"	<a href="#">X44-402</a>	0.812"	0.748"
3/32"	1/16"	3/32"	1/16"	<a href="#">X33-202</a>	0.712"	0.748"
3/32"	3/32"	3/32"	3/32"	<a href="#">X33-303</a>	0.712"	0.736"
3/32"	1/8"	3/32"	1/8"	<a href="#">X44-303</a>	0.812"	0.736"
3/32"	3/32"	3/32"	1/8"	<a href="#">X43-303</a>	0.762"	0.736"
1/8"	1/16"	1/16"	1/8"	<a href="#">X42-402</a>	0.734"	0.748"
1/8"	1/8"	1/8"	1/8"	<a href="#">X44-404</a>	0.812"	0.826"

## Compression Fittings

### Brass #10-32 to Tube Compression Fittings with Captivated O-Rings

(10/pack)

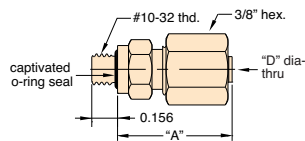

Tube (OD)	Order No.	"A"	"D" Dia.
1/8"	<a href="#">11923</a>	0.694"	0.090"
1/16"	<a href="#">15160</a>	0.694"	0.046"

Options: (-ENP) Replacement Ferrule and nut #15155 (11923 only)



### Brass NPT to 1/8" O.D. Tube Compression Fittings

(10/pack)

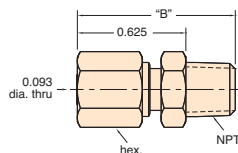

NPT	Order No.	"B"	Hex
1/8"	<a href="#">3810-1</a>	1.035"	7/16"
1/16"	<a href="#">3810-2</a>	0.914"	3/8"

Options: (-ENP) Replacement Ferrule and nut #15155

# #10-32 NIPPLES & COUPLINGS

## Male #10-32 Nipple

(10/pack)

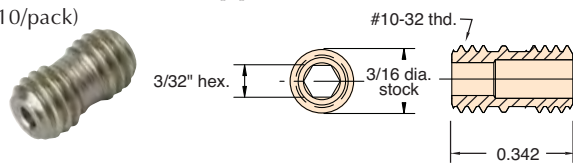

**Order No.**

15453

**Material:** Stainless steel

**Seals:** Sealant necessary

**Use:** Excellent for a surface to surface connection of female #10-32 products



## #10-32 Male Nipple

(10/pack)

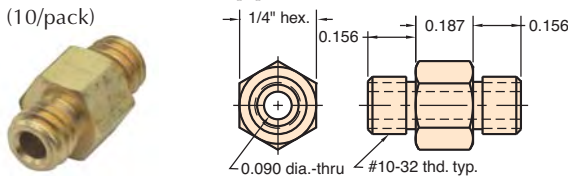

**Order No.**

11999

**Thread:** #10-32 both ends

**Options:** (-ENP)

**Gaskets:** Nitrile 2 furnished

**Use:** For coupling cylinders directly to valves, and many other coupling arrangements



## #10-32 Female Hex Coupling

(10/pack)

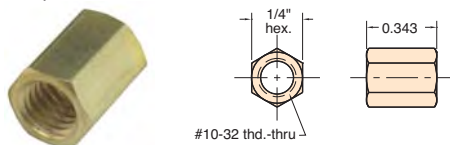

**Order No.**

15004

**Thread:** #10-32 tapped

**Options:** (-ENP)

**Use:** For coupling two #10-32 male fittings



## #10-32 Extension Fitting

(10/pack)

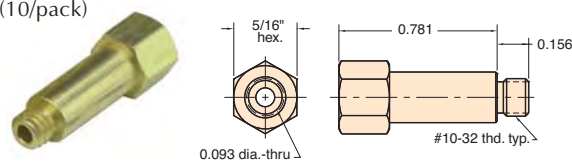

**Order No.**

15010

**Gasket:** Nitrile furnished

**Options:** (-ENP)

**Use:** To provide extension for convenience in assembling components



## #10-32 Swivel Fitting

(5/pack)

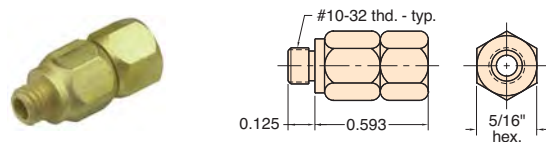

**Order No.**

15040

**Thread:** #10-32

**Options:** (-ENP)

**Seals:** Nitrile o-ring (gasket furnished package only)

**Use:** Allows connection to rotate for tightening in confined spaces

**Note:** Used for positioning not for rotary connector



## 1/8" NPT to #10-32 Swivel Adapter

(5/pack)

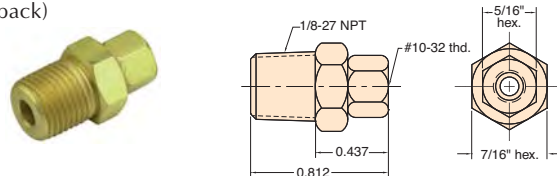

**Order No.**

15060

**Thread:** 1/8-27 NPT male and #10-32 tapped **Options:** (-ENP)

**Seals:** Nitrile o-ring

**Use:** Allows connection to rotate for tightening in confined spaces.

**Note:** Used for positioning not for rotary connector



## Female 1/8" NPT to #10-32 Swivel Adapter

(5/pack)

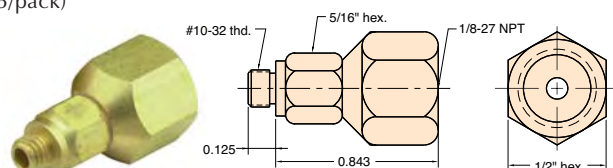

**Order No.**

15050

**Thread:** #10-32 and tapped for 1/8-27 NPT **Options:** (-ENP)

**Seals:** Nitrile o-ring (gasket furnished package only)

**Use:** Allow connection to rotate for tightening in confined spaces

**Note:** Used for positioning not for rotary connector





All fittings are Brass unless otherwise noted

## #3-56 Couplings

(10/pack)

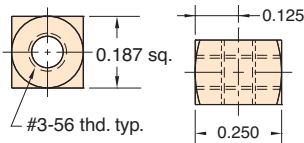

Porting	Order No.
In-Line	<a href="#">11749-1</a>
"T"	<a href="#">11749-2</a>
"X"	<a href="#">11749-3</a>

**Thread:** M2.5 - 0.45 (#3-56 US equiv.) **Options:** (-ENP)  
**Use:** Threads into Clippard subminiature cylinder; fits 1/16" I.D. hose

## #10-32 "X" Coupling

(10/pack)

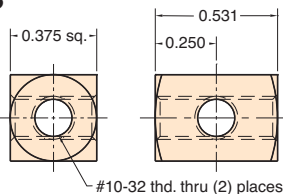

Order No.
<a href="#">15002-5</a>

**Options:** (-ENP)

## #10-32 to #10-32 Fittings

(10/pack)

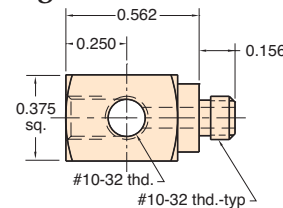

Porting	Order No.	Hex.
"L"	<a href="#">15002-2</a>	7/16"
"T"	<a href="#">15002-3</a>	7/16"
"X"	<a href="#">15002-4</a>	7/16"

**Options:** (-ENP)

## Adjustable #10-32 "L" Fitting

(5/pack)

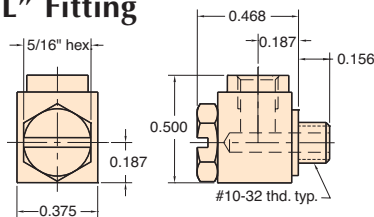

Order No.
<a href="#">15002-1</a>

**Stud:** Stainless steel hex head with screwdriver slot (12292)  
**Seals:** Nitrile o-ring furnished **Options:** (-ENP)

## Adjustable #10-32 "T" Fitting

(5/pack)

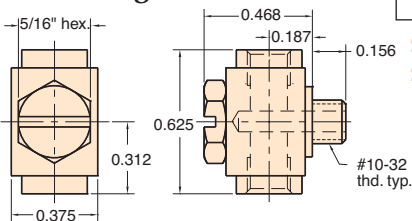

Order No.
<a href="#">15002-6</a>

**Stud:** Stainless steel hex head with screwdriver slot (12292)  
**Seals:** Nitrile o-ring furnished **Options:** (-ENP)



## Miniature #10-32 Manifold Stud

(10/pack)

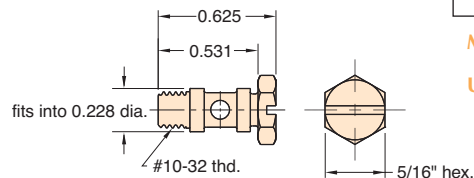

Order No.
<a href="#">12292</a>

**Material:** Stainless steel **Seals:** Nitrile o-ring and gasket furnished

**Use:** This hollow, cross-drilled stud is useful for connecting specially-made manifolds to multiple ports of valves or cylinders, eliminating need for external fittings with hose

## 1/8" NPT to #10-32 Adapter Fittings

(5/pack)

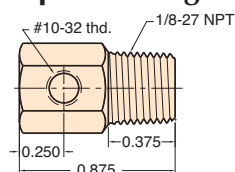

Porting	Order No.	Hex.
"L"	<a href="#">15090-1</a>	7/16"
"T"	<a href="#">15090-2</a>	7/16"
"X"	<a href="#">15090-3</a>	7/16"

**Options:** (-ENP)

All fittings are Brass unless otherwise noted

## #10-32 Thread to Male NPT

(5/pack)

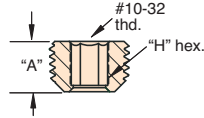

External Thd.	Order No.	"A"	"H" Hex.
1/8" NPT	<a href="#">15036</a>	0.250"	5/32"

Will adapt standard pipe to fittings and Clippard miniature components

To be used with a thread sealant in applications where low profile (no hex) or flush mount is desired.



## #10-32 Thread to Male NPT

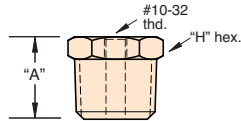

External Thd.	Order No.	"A"	"H" Hex.	Pkg. Qty.
1/16" NPT	<a href="#">1CIF</a>	0.468"	5/16"	10
1/8" NPT	<a href="#">2CPF</a>	0.531"	7/16"	10
1/4" NPT	<a href="#">4COF</a>	0.562"	9/16"	10
3/8" NPT	<a href="#">6CWF</a>	0.687"	11/16"	5
1/2" NPT	<a href="#">8CZF</a>	0.812"	13/16"	5

Will adapt standard pipe to fittings and Clippard miniature components.  
(-ENP) optional.

## 1/16" NPT Thread to Male NPT

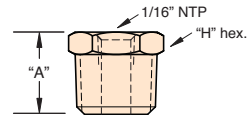

External Thd.	Order No.	"A"	"H" Hex.	Pkg. Qty.
1/8" NPT	<a href="#">2CPK</a>	0.531"	7/16"	10
1/4" NPT	<a href="#">4COK</a>	0.562"	9/16"	10
3/8" NPT	<a href="#">6CWK</a>	0.687"	11/16"	5
1/2" NPT	<a href="#">8CZK</a>	0.812"	13/16"	5

Will adapt standard pipe to fittings and Clippard miniature components.  
(-ENP) optional.

## 1/8" NPT Thread to Male NPT

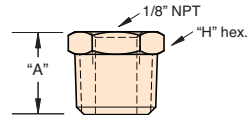

External Thd.	Order No.	"A"	"H" Hex.	Pkg. Qty.
1/4" NPT	<a href="#">4CON</a>	0.562"	9/16"	10
3/8" NPT	<a href="#">6CWN</a>	0.687"	11/16"	5
1/2" NPT	<a href="#">8CZN</a>	0.812"	13/16"	5

Will adapt standard pipe to fittings and Clippard miniature components.  
(-ENP) optional.

## 1/4" NPT Thread to Male NPT

(5/pack)

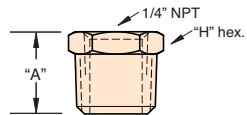

External Thd.	Order No.	"A"	"H" Hex.
3/8" NPT	<a href="#">6CWY</a>	0.687"	11/16"
1/2" NPT	<a href="#">8CZY</a>	0.812"	13/16"

Will adapt standard pipe to fittings and Clippard miniature components.  
(-ENP) optional.

## 3/8" NPT Thread to Male NPT

(5/pack)

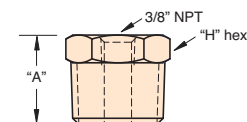

External Thd.	Order No.	"A"	"H" Hex.
1/2" NPT	<a href="#">8CZD</a>	0.812"	13/16"

Will adapt standard pipe to fittings and Clippard miniature components.  
(-ENP) optional.

## Tips On Using Minimatic® Fittings

### Hose or Tubing Size

The use of different sizes of hose or tubing in your circuits deserves some care and consideration. In general, follow this guide for the size of hose or tubing you use.

For air logic circuits, we recommend:  
1/16" I.D. for pilots  
1/8" I.D. for supplies and outputs

## #10-32 Screw Plugs

**Gasket:** Nitrile furnished package only

**Use:** For plugging unused ports in manifolds, air lines and other devices

**Use:** For plugging unused ports in manifold, air lines and other devices that require a flush surface plug; use 3/32 Allen hex wrench to install

**Note:** Thread sealant recommended

### Screw Plug

(10/pack)

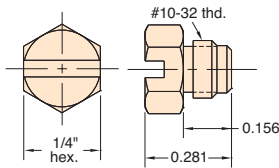

Order No.	Description
<a href="#">11755</a>	Brass Plug

**Options:** (-ENP)



### Screw Plug with Captivated O-Ring

(10/pack)

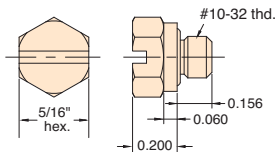

Order No.	Description
<a href="#">11782-7-ENP</a>	ENP Plug

### Headless Plug

(10/pack)

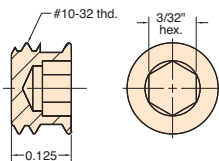

Order No.	Description
<a href="#">0035-2</a>	Stainless Steel Headless Plug

*Thread sealant required*

### Bulkhead Fittings

(15027 5/pack)

(15029 1/pack)

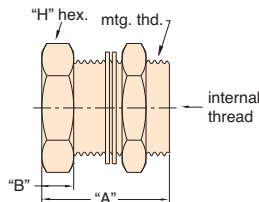

Internal Thd.	Mtg. Thread	Order No.	"A"	"B"	"H" Hex.
#10-32	#15/32-32	<a href="#">15027</a>	0.500"	0.125"	9/16"
1/8" NPT	3/4-20	<a href="#">15029-1</a>	1.000"	0.250"	7/8"
1/4" NPT	3/4-20	<a href="#">15029-2</a>	1.000"	0.250"	7/8"

**Options:** (-ENP)

**Locking Nut:** Two steel lockwashers



Clippard's reputation of building jigs, fixtures and machines as well as modifying existing machines to improve productivity is carried on in its well equipped machine shop. New product prototypes are crafted by experienced engineers and machinists.



## Gaskets

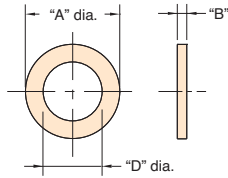

**Nitrile** gaskets are designed for use with #10-32 threads; included with packaged Clippard fittings. -40 to 250°F.

**FKM** gaskets are designed for use with #10-32 threads in high temperature applications. -20 to 450°F.

Material	Order No.	"A" Dia.	"B"	"D" Dia.
Nitrile	<a href="#">11761-2</a>	0.240"	0.022"	0.150"
FKM	<a href="#">11761-8</a>	0.240"	0.022"	0.150"
Nylon	<a href="#">11761-4</a>	0.307"	0.031"	0.192"
EPDM	<a href="#">11761-7</a>	0.240"	0.022"	0.150"

*Designed for use with #10-32 threads*

**Nylon** gaskets are designed for use with #10-32 threads in applications that require nylon for chemical compatibility. 40 to 200°F.

**EPDM** gaskets are designed for use with #10-32 threads in applications that require EPDM for low temperature or chemical compatibility; do not use with petroleum-based lubricants. -60 to 300°F.

**Gasket Tips** Gaskets are recommended for use with Clippard fittings. They provide snug, dependable seals without extra effort or materials. The most popular gasket for static sealing of #10-32 threads is the 11761-2 Nitrile Gasket. This gasket is included with packaged fittings and comes installed on a variety of Minimatic® slip-on fittings. Overtightening fittings with gaskets may have a tendency to extrude the gasket. While this may be a concern, the actual sealing is being accomplished by a small piece of the gasket at the base of the threads.

**Sealants** There are a number of brands of anaerobic sealants that may be used with Clippard fittings. Anaerobic sealants are applied wet and harden when no longer exposed to air. their proper use results in a very effective, low cost seal. There are several alternate sealing methods:

1. sealant alone
2. gasket alone
3. gasket and sealant combination
4. home alone

The first two methods will provide adequate sealing for normal air pressures. When extra resistance to vibration is necessary or a permanent orientation of the fitting is required, use of the combination of both gasket and sealant is recommended.

## Tips On Using Barb Fittings

**Hose or Tubing Size.** The use of different sizes of hose or tubing in your circuits deserves some care and consideration. In general, follow the manufacturer's guide for the size of hose or tubing you use. For air logic circuits, we recommend 1/16" ID for pilots and 1/8" ID for supplies and outputs.

**Swivel Fittings.** Minimatic® swivel connector fittings are very efficient in applications where joints need to be disconnected and reconnected frequently. Made with a threaded connection on one end and a swivel connection on the other, these fittings provide a true cost savings on pneumatic circuit designs. They are valuable also where short lengths of hose are being connected. Note: These are not rotating joints. They are for assembly benefits . . . not as a constant rotation connection.

**Tightening #10-32 Fittings.** TIGHTEN WITH CARE. Often a "finger tight" connection between Clippard fittings with anaerobic sealant is all that is required. When using a gasket, most Clippard #10-32 threaded fittings require no more than 9 inch-pounds of torque to seal. We recommend that this force not be exceeded. Use wrench #11770 with a 1/4" and 5/16" open-end.

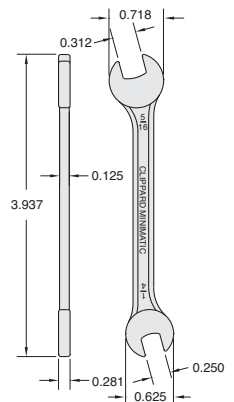

All fittings are Brass unless otherwise noted

## Brass Mufflers

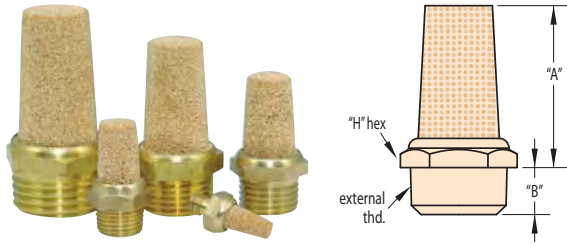

External Thd.	Order No.	"A"	"B"	"H" Hex.
#10-32	11130-N	0.560"	0.195"	8 mm
1/8" NPT	11130-P	0.686"	0.259"	12 mm
1/4" NPT	11130-Q	0.860"	0.300"	14 mm
3/8" NPT	11130-W	1.129"	0.330"	17 mm
1/2" NPT	11130-Z	1.331"	0.386"	21 mm

Sintered bronze muffler (40 micron), Nitrile gasket furnished on #11130-N only

## 1/8" NPT Muffler

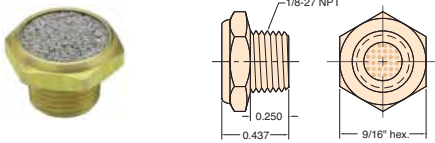

Order No.	Description
15080	1/8" NPT Muffler

**Material:** Solid brass body; sintered stainless steel insert (100 micron)

**Thread:** 1/8" NPT

**Options:** (-ENP)

**Use:** To muffle exhaust for quiet system operation



## #10-32 ENP Muffler

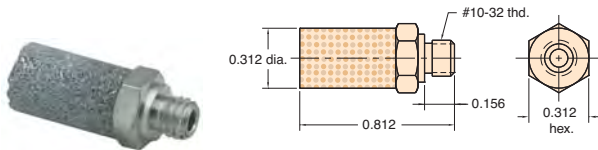

Order No.	Description
15070	#10-32 Muffler

**Material:** Electroless nickel plated brass body sintered stainless steel muffler (60 micron)

**Gasket:** Nitrile furnished

**Use:** To muffle exhaust for quiet system operation

## 12-Port Manifold

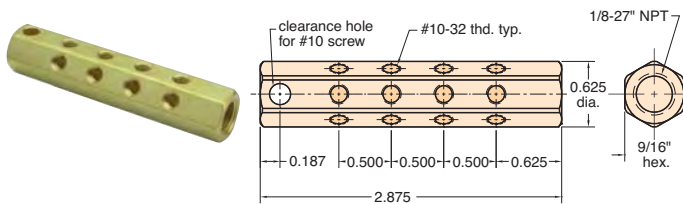

Order No.
MAN-12

**Material:** Brass

**Options:** (-ENP)

**Thread:** Tapped ports: 1/8" standard pipe tapped inlet

**Mounting:** 13/64" diameter mounting hole

**Use:** May be mounted on jigs, fixtures or machinery to provide up to 12 convenient #10-32 outlets from one standard 1/8" pipe connection; may be used with any Clippard #10-32 fittings, quick connects and many other devices; unused ports can be plugged with screw plug 11755



## 6-Port Rotary Manifold

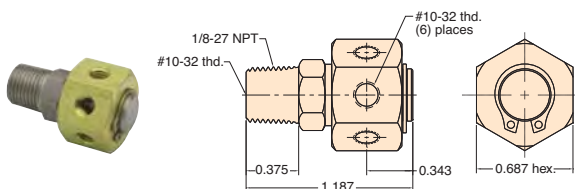

Order No.
MRM-6

**Material:** Brass and stainless steel

**Thread:** 1/8" NPT for inlet is also tapped #10-32; outlet consists of 6 ports tapped #10-32

**Seals:** Nitrile o-ring furnished

**Working Range:** 250 psig max. **Air Flow:** 5.9 scfm @ 50 psig

**Use:** May be used either as a rotary joint or as a stationary manifold; ideal for distributing air or liquid from center column onto a rotary index table; unused ports may be plugged with screw plug 11755 and gasket

Low RPM applications



## Miniature Terminal Blocks

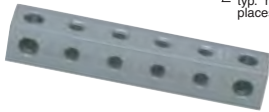
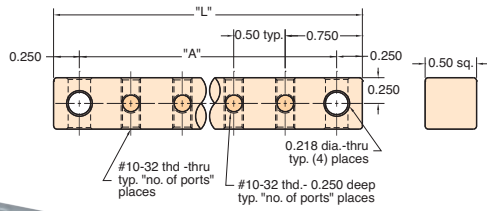

15028-4 pictured at left

Order No.	# of Ports	"A"	"L"
<a href="#">15028-4</a>	4	2.500"	3.000"
<a href="#">15028-6</a>	6	3.500"	4.000"
<a href="#">15028-8</a>	8	4.500"	5.000"
<a href="#">15028-10</a>	10	5.500"	6.000"

**Material:** Anodized aluminum

**Thread:** #10-32 tapped ports

**Mounting:** With two 7/32: diameter mounting holes

**Use:** To help organize connections in circuit boxes, control panels and machine piping; cross drilled mounting holes permit mounting of "T" in any direction; use screw plug 11755 to plug unused ports

## #10-32 Block Manifolds

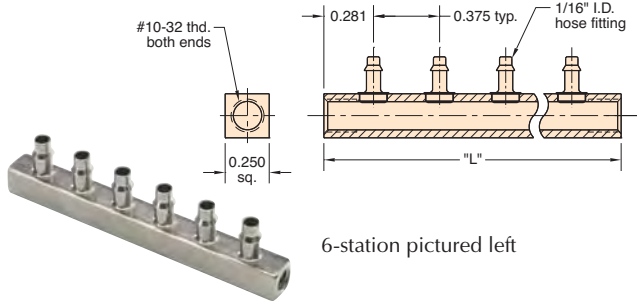

6-station pictured left

Order No.	# of Stations	Hose Barbs	"L"
<a href="#">BTT2-04</a>	4	1/16" I.D.	1.687"
<a href="#">BTT2-06</a>	6	1/16" I.D.	2.437"
<a href="#">BTT2-08</a>	8	1/16" I.D.	3.187"
<a href="#">BTT2-10</a>	10	1/16" I.D.	3.937"
<a href="#">BTT2-12</a>	12	1/16" I.D.	4.687"
<a href="#">BTT4-04</a>	4	1/8" I.D.	1.687"
<a href="#">BTT4-06</a>	6	1/8" I.D.	2.437"
<a href="#">BTT4-08</a>	8	1/8" I.D.	3.187"
<a href="#">BTT4-10</a>	10	1/8" I.D.	3.937"
<a href="#">BTT4-12</a>	12	1/8" I.D.	4.687"

One end may be used as the air supply to the manifold and the other end plugged.

## #10-32 Block Manifolds with #6 Screws

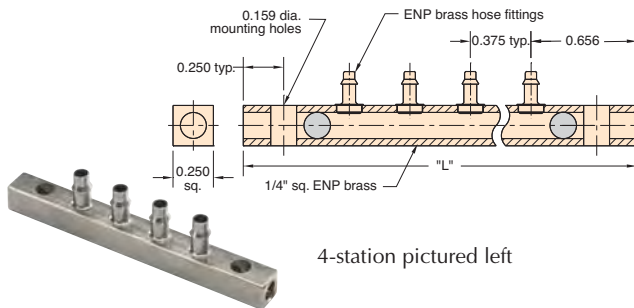

4-station pictured left

Order No.	# of Stations	Hose Barbs	"L"
<a href="#">BHH2-04</a>	4	1/16" I.D.	2.437"
<a href="#">BHH2-06</a>	6	1/16" I.D.	3.187"
<a href="#">BHH2-08</a>	8	1/16" I.D.	3.937"
<a href="#">BHH2-10</a>	10	1/16" I.D.	4.687"
<a href="#">BHH2-12</a>	12	1/16" I.D.	5.437"
<a href="#">BHH4-04</a>	4	1/8" I.D.	2.437"
<a href="#">BHH4-06</a>	6	1/8" I.D.	3.187"
<a href="#">BHH4-08</a>	8	1/8" I.D.	3.937"
<a href="#">BHH4-10</a>	10	1/8" I.D.	4.687"
<a href="#">BHH4-12</a>	12	1/8" I.D.	5.437"

One of the stations must be used as the air supply to the manifold.

## CUSTOMer solutions

If you need a product that fits your application perfectly, Clippard has the capability to design or modify one of its products to suit your exact needs. We understand that a standard catalog product may be close but not be exactly what you need. **Let us know YOUR Need, and we will help to find YOUR Solution!**



### Bleed Valves

This miniature device is a vent or bleed valve that uses a tire stem valve in a small panel-mounted body with integral hose barb.



### Standard fittings don't always fit!

Clippard manufactures custom fittings to meet your exact requirements.





## In-Line Manifolds

Clippard's aluminum pipe thread manifolds are an economical and efficient choice for grouping pneumatic valves and other components in applications where space is limited. In addition, manifolds help to reduce potential leak points and allow for faster installation, all with one common air supply and less piping.

A unique feature of this series of manifolds is a bottom T-slot mounting system which allows for secure mounting using only two carriage bolts on any center distance along the length of the manifold. Hardware Kit ordered separately (MAN-MH).

**Medium:** Air or Liquid

**Material:** Clear Anodized Aluminum



**Outlet Ports (Top Ports):** 1/8" NPT or 1/4" NPT

**Inlet Ports (End Ports):** 1/4" NPT or 3/8" NPT

**Mounting:** Top-to-bottom and front-to-back mounting holes as well as bottom T-slot mounting system

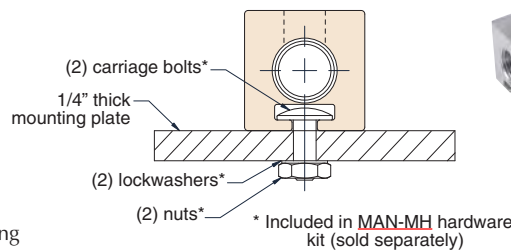
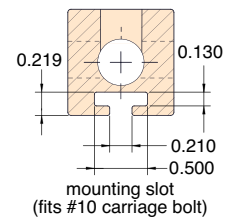
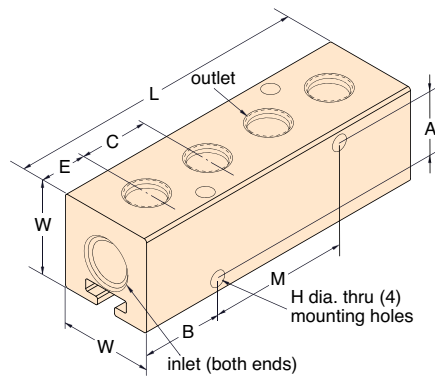

Part No.	Stations **	Width "W"	End Inlets	Top Outlets	Center "C"***	End "E"	Length "L"	Mtg. "M"	"A"	"B"	Hole* "H"
<a href="#">MAN-ASF1-04</a>	4						3.250"	1.500"			
<a href="#">MAN-ASF1-06</a>	6	1"	1/4" NPT	1/8" NPT	0.750"	0.500"	4.750"	3.000"	0.700"	0.875"	0.172"
<a href="#">MAN-ASF1-08</a>	8	Sq.					6.250"	4.500"			(#8 screw)
<a href="#">MAN-ASF1-10</a>	10						7.750"	6.000"			
<a href="#">MAN-ALF1-04</a>	4						3.250"	1.500"			
<a href="#">MAN-ALF1-06</a>	6	1 1/4"	3/8" NPT	1/8" NPT	0.750"	0.500"	4.750"	3.000"	0.875"	0.875"	0.201"
<a href="#">MAN-ALF1-08</a>	8	Sq.					6.250"	4.500"			(#10 screw)
<a href="#">MAN-ALF1-10</a>	10						7.750"	6.000"			
<a href="#">MAN-ALF2-04</a>	4						4.125"	1.750"			
<a href="#">MAN-ALF2-06</a>	6	1 1/4"	3/8" NPT	1/8" NPT	0.875"	0.750"	5.875"	3.500"	0.875"	1.187"	0.201"
<a href="#">MAN-ALF2-08</a>	8	Sq.					7.625"	5.250"			(#10 screw)
<a href="#">MAN-ALF2-10</a>	10						9.375"	7.000"			
<a href="#">MAN-ALY2-04</a>	4						3.875"	1.750"			
<a href="#">MAN-ALY2-06</a>	6	1 1/4"	3/8" NPT	1/4" NPT	0.875"	0.625"	5.625"	3.500"	0.875"	1.062"	0.201"
<a href="#">MAN-ALY2-08</a>	8	Sq.					7.375"	5.250"			(#10 screw)
<a href="#">MAN-ALY2-10</a>	10						9.125"	7.000"			
<a href="#">MAN-ALY6-04</a>	4						5.875"	2.750"			
<a href="#">MAN-ALY6-06</a>	6	1 1/4"	3/8" NPT	1/4" NPT	1.375"	0.875"	8.625"	5.500"	0.875"	1.562"	0.201"
<a href="#">MAN-ALY6-08</a>	8	Sq.					11.375"	6.250"			(#10 screw)
<a href="#">MAN-ALY6-10</a>	10						14.125"	11.000"			

\* 0.172" can be tapped by the user for #10-32 thread; 0.201" may be tapped by user for 1/4"-20 thread for mounting.

\*\* Variations available—consult factory.

The Minimatic J-Series quick connect consists of two component parts that are joined to form the complete connector. The valve body contains a 2-way spring-loaded poppet valve that is generally connected to the main air supply. When the poppet is not depressed, the air supply is shut-off by this valve. The Cap contains a valve depressor that when assembled to the valve body, depresses the poppet allowing air to flow from the main supply to circuitry or equipment downstream. Valve body & cap assemblies contain both components.

M J Q C - □ □ □ □

**Cap**

- B4** - 1/8" hose barb
- FT** - #10-32 female thd.
- PF** - Panel mount #10-32 female thd.
- PB** - Panel mount 1/8" hose barb
- MP** - 1/8" male NPT thd.
- MQ** - 1/4" male NPT thd.

**Valve Body**

- B4** - 1/8" hose barb
- FT** - #10-32 female thd.
- MT** - #10-32 male thd.
- MP** - 1/8" male NPT thd.
- FP** - 1/8" female NPT thd.
- MQ** - 1/4" male NPT thd.

To order just the cap

MJQC - C □ □

To order just the valve body

MJQC - V □ □

## Valve Body & Cap Assemblies

\*1/8" Barb - fits 1/8" I.D. hose. Ideal for use with Clippard URH1-0804 polyurethane hose.

- High flow of 14 scfm @ 100 psig
- Space saving attractive miniature design
- Wide variety of connectors
- Adds convenience to equipment and circuits
- Brass body, electroless nickel plated
- Non-corrosive - Acetal poppet
- Fills the gap between clumsy, large quick connects and smaller quick connects with less flow
- Nitrile seals, positive shut off
- Positive threaded connection, stays connected
- Medium: Air, Oil, or Water
- Working Pressure: 0 to 150 psig max.

Minimatic J-Series quick connect fittings are very compact yet provide a very high flow. The electroless nickel plated brass body is available with #10-32 threads (M or F), 1/8" NPT threads (M or F), 1/4" NPT threads (M) or a 1/8" hose single barb configuration.

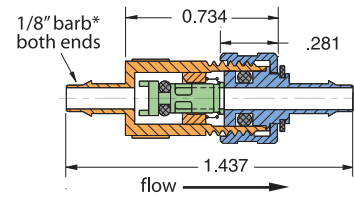

Part No.	Description
MIQC-B4B4	1/8" Barb Outlet, 1/8" Barb Inlet (MJQC-VB4/MJQC-CB4 Combo)

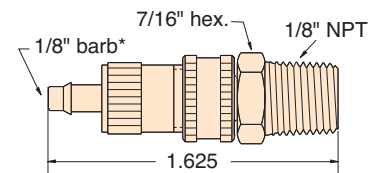

Part No.	Description
MIQC-MPB4	1/8" Barb Outlet, 1/8" NPT Inlet (MJQC-VB4/MJQC-CMP Combo)

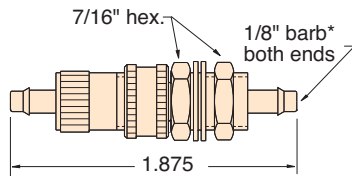

Part No.	Description
MIQC-PBB4	1/8" Barb Outlet, 1/8" Barb Inlet with Thread (MJQC-VB4/MJQC-CPB Combo)

(supplied with mounting nut and two washers)

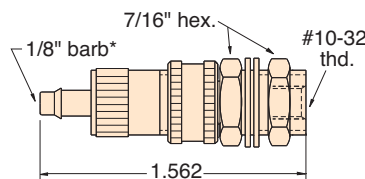

Part No.	Description
MIQC-PFB4	1/8" Barb Outlet, #10-32 Inlet (MJQC-VB4/MJQC-CPF Combo)

(supplied with mounting nut and two washers)

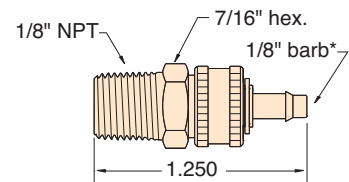

Part No.	Description
MIQC-B4MP	1/8" NPT Outlet, 1/8" Barb Inlet (MJQC-VMP/MJQC-CB4 Combo)

## Caps with Open Flow Path

Minimatic J-Series quick connect fittings are ideal for use in jigs, fixtures, feeding devices, logic control circuitry and automatic or semi-automatic machinery. Assembly is simple, and the tightening of the knurled cap assures a positive, leakproof, high pressure connection that will stay connected.

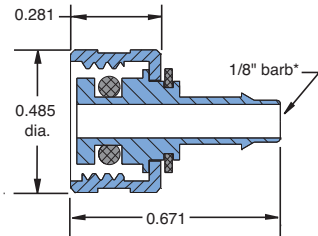

**Part No.** MIQC-CB4 **Description**  
1/8" Barb

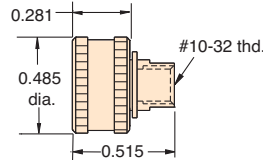

**Part No.** MIQC-CFT **Description**  
#10-32

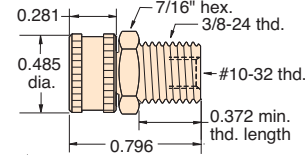

**Part No.** MIQC-CPF **Description**  
3/8" Thread

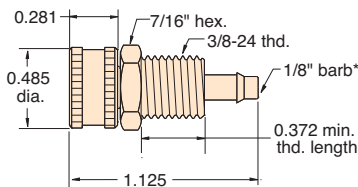

**Part No.** MIQC-CPB **Description**  
1/8" Barb  
*(supplied with mounting nut and two washers)*

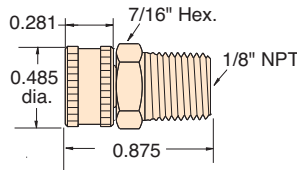

**Part No.** MIQC-CMP **Description**  
1/8" NPT

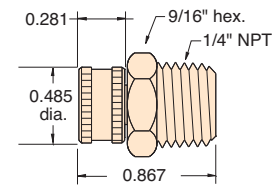

**Part No.** MIQC-CMQ **Description**  
1/4" NPT

## Valve Bodies with Shut-Off Valve

Minimatic J-Series quick connect fittings are very compact yet provide a high flow of 14 scfm @ 100 psig. The electroless nickel plated brass body is available with #10-32 threads (M or F), 1/8" NPT threads (M or F), 1/4" NPT threads (M) or a 1/8" hose single barb configuration that is ideal for use with Clippard URH1-0804 polyurethane hose.

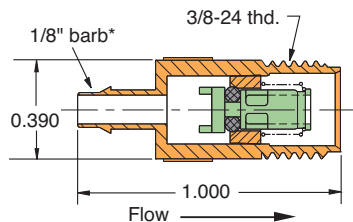

**Part No.** MIQC-VB4 **Description**  
1/8" Barb, 3/8-24 Thd.

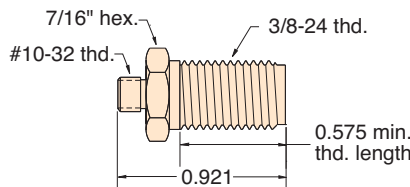

**Part No.** MIQC-VMT **Description**  
#10-32 Male, 3/8-24 Thd.  
*(supplied with mounting nut and two washers)*

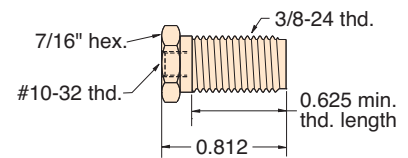

**Part No.** MIQC-VFT **Description**  
#10-32 Female, 3/8-24 Thd.  
*(supplied with mounting nut and two washers)*

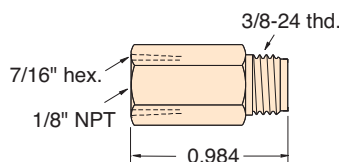

**Part No.** MIQC-VFP **Description**  
1/8" NPT Female, 3/8-24 Thd.

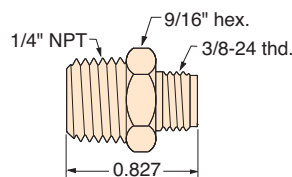

**Part No.** MIQC-VMQ **Description**  
1/4" NPT Male, 3/8-24 Thd.

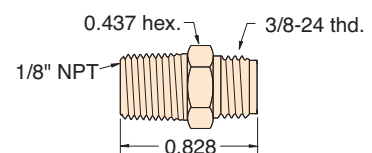

**Part No.** MIQC-VMP **Description**  
1/8" NPT Male, 3/8-24 Thd.

\*1/8 Barb - fits 1/8" I.D. hose. Ideal for use with Clippard URH1-0804 polyurethane hose.

## Push-Quick Fittings with MJQC Quick-Connect Port



These 1/4" fittings combine the quick, easy Push-Quick functionality with the flexibility and security of the Quick-Connect series with no circuit interruption. MJQC Quick-Connect Caps (ordered separately on previous page) attach to the threaded port allowing for a variety of uses.

- Serves as an easy connection point for temporary functions/circuitry
- Quickly test for air flow
- Easy connection to valves, cylinders, hose, etc.
- Check air pressure via a gauge
- Use as a dump valve/vent

Part No.	Description
<a href="#">PQ-RT08QC</a>	Run Tee with 3/8-24 Thread
<a href="#">PQ-BT08QC</a>	Branch Tee with 3/8-24 Thread

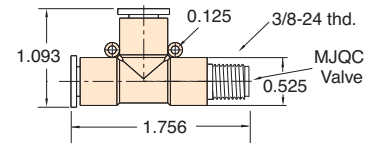

**PQ-RT08QC**

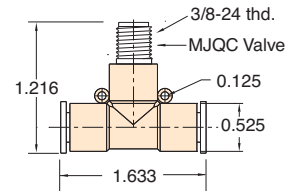

**PQ-BT08QC**

## Quick Connect Assembly

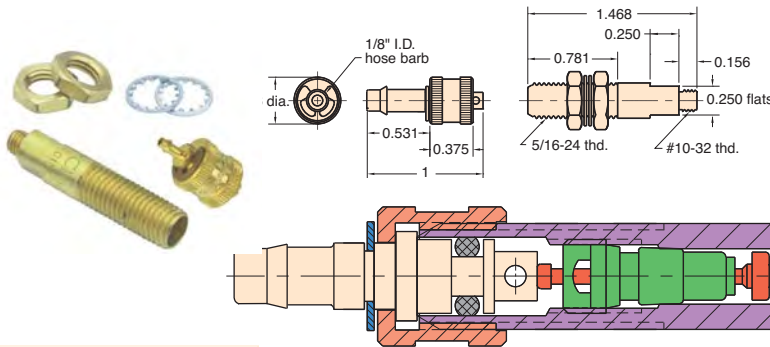

Part No.	Description
<a href="#">MQC-2S</a>	QC Assembly

**Type:** One way check quick connect assembly of valve body MQC-V2 and hose connector MQC-F

**Material:** Body- brass, Stem- brass

**Seals:** Nitrile

**Working Pressure:** 0 to 300 psig

**Air Flow:** 3.0 scfm @ 50 psig  
5.8 scfm @ 100 psig

**Triple Barb:** Order [MQC-2](#)

## Quick Connect Assembly

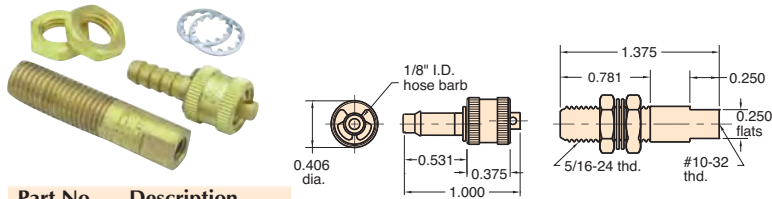

Part No.	Description
<a href="#">MQC-3S</a>	QC Assembly

**Type:** One way check quick connect assembly of valve body MQC-V3 and hose connector MQC-F

**Material:** Body- brass, Stem- brass

**Seals:** Nitrile

**Working Pressure:** 0 to 300 psig

**Air Flow:** 3.0 scfm @ 50 psig  
5.8 scfm @ 100 psig

**Triple Barb:** Order [MQC-3](#)

## Valve Body



Part No.	Description
<a href="#">MQC-V2</a>	Valve Body

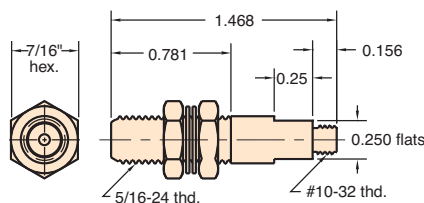

**Material:** Brass

**Thread:** #10-32 male

**Mounting:** In panel or bracket to 1/4" thick with two 7/16" mounting nuts and lockwashers furnished; also screws directly into operative unit or manifold

**Seals:** Nitrile

**Use:** For connection with external shut-off to external hose, use hose connectors: MQC-F, MQC-FT, MQC-F2

**Options:** (-ENP)

All fittings are Brass

## Valve Body

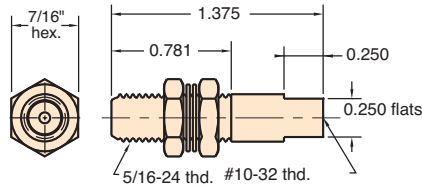

Part No.	Description
<a href="#">MQC-V3</a>	Valve Body

**Thread:** Tapped #10-32

**Mounting:** In panel or bracket to 1/4" thick with two 7/16" mounting nuts and lockwashers furnished; like MQC-V2, but end is tapped #10-32 instead of threaded

**Seals:** Nitrile

**Use:** For connection with external shut-off to external hose, use hose connectors: MQC-F, MQC-FT, MQC-F2

**Options:** (-ENP)



## Valve Body

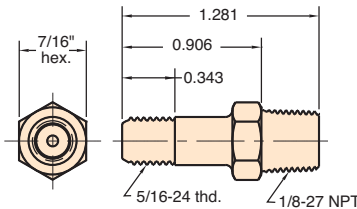

Part No.	Description
<a href="#">MQC-VP</a>	Valve Body

**Thread:** 1/8" NPT base; 5/16-24 body

**Use:** For connection with external shut-off to external hose, use hose connectors: MQC-F, MQC-FT, MQC-F

**Seals:** Nitrile

**Options:** (-ENP)

## 1/8" Hose Connector

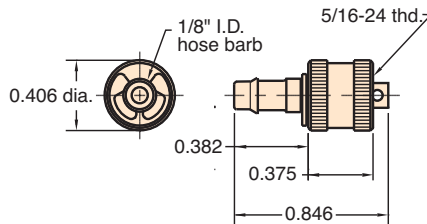

Part No.	Description
<a href="#">MQC-FS</a>	Hose Connector

**Thread:** I.D. of knurled end screws onto male end of valve bodies

**For Use With:** 1/8" I.D. Vinyl, Nitrile or braided hose

**Installation:** Simply push hose onto barbed end and secure with hose clamp 5000-1, 5000-2 or 5000-1A.

**Seals:** Nitrile

**Options:** (-ENP)

**Triple Barb:** Order [MQC-F](#)

## 1/16" Hose Connector

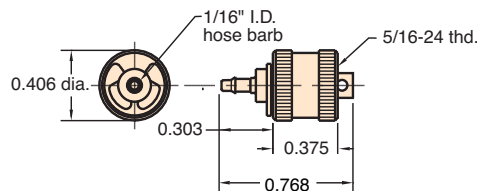

Part No.	Description
<a href="#">MQC-F2S</a>	Hose Connector

**Thread:** I.D. of knurled end screws onto male end of valve bodies

**For Use With:** Subminiature VYH1-0402-CLT 1/16" ID vinyl hose

**Installation:** Simply push hose onto barbed end and secure with slip-over hose clamp furnished

**Seals:** Nitrile

**Options:** (-ENP)

**Triple Barb:** Order [MQC-F2](#)



## #10-32 Tapped Connector

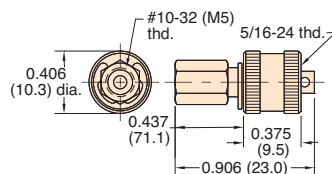

Part No.	Description
<a href="#">MQC-FT</a>	#10-32 Connector

**Thread:** Outlet is tapped #10-32. I.D. of knurled end screws onto male end of valve bodies: MQC-V2, MQC-V3, MQC-VP

**Mounting:** Outlet mounts with #10-32 short coupling [11999](#)

**Seals:** Nitrile

**Options:** (-ENP)



**Tip** When assembling #10-32 threaded fittings with gaskets, turn the fitting in until the gasket contacts the surface. Then give the fitting less than a 1/4 turn to achieve a good seal.



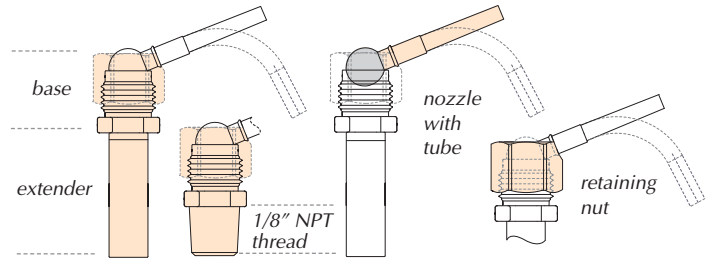
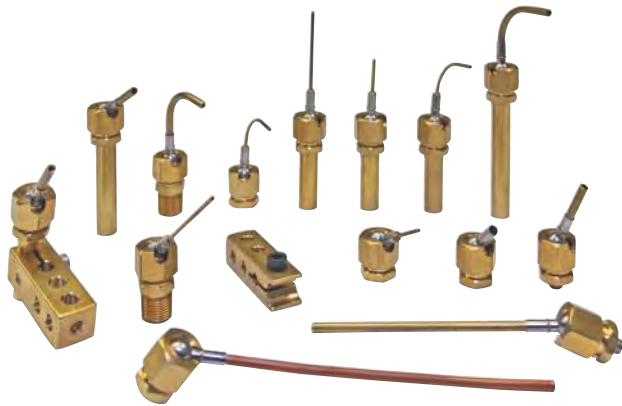

**Air Jet Bases & Extenders\***

**Order No.**

- AJB-F Base with #10-32 Female Thread, No Extender
- AJB-N Base with #10-32 Male Thread, No Extender
- AJB-P Base with 1/8" NPT Thread, No Extender
- AJB-10 Base with #10-32 Female Thread, 1" Extender
- AJB-15 Base with #10-32 Female Thread, 1.5" Extender
- AJB-20 Base with #10-32 Female Thread, 2" Extender

\* All come complete with retaining nut. Nozzles ordered separately below

**Air Jet Nozzles**

- AJT-B Ball Nozzle Only
- AJT-1S1 Ball Nozzle with 1/32" ID Straight Brass Tube, 1"
- AJT-1S2 Ball Nozzle with 1/32" ID Straight Brass Tube, 2"
- AJT-1S3 Ball Nozzle with 1/32" ID Straight Brass Tube, 3"
- AJT-2S1 Ball Nozzle with 1/16" ID Straight Brass Tube, 1"
- AJT-2S2 Ball Nozzle with 1/16" ID Straight Brass Tube, 2"
- AJT-2S3 Ball Nozzle with 1/16" ID Straight Brass Tube, 3"
- AJT-3S1 Ball Nozzle with 3/32" ID Straight Brass Tube, 1"
- AJT-3S2 Ball Nozzle with 3/32" ID Straight Brass Tube, 2"
- AJT-3S3 Ball Nozzle with 3/32" ID Straight Brass Tube, 3"
- AJT-2F4 Ball Nozzle with Flexible Copper Tube, 4" 1/16" ID only)
- AJT-1N Ball Nozzle with 1/32" ID 90° Tube
- AJT-2N Ball Nozzle with 1/16" ID 90° Tube
- AJT-3N Ball Nozzle with 3/32" ID 90° Tube

**Accessories**

- AIK Air Jet Kit (see web site for details)
- AJS Mounting Squeeze Block
- 27801-PKG Retaining Nut

Air jets are used extensively within the manufacturing environment. They are designed to deliver a concentrated flow of air or liquid to a specific location. They are used in blow-off, cleaning, drying, part ejecting, and cooling applications. Clippard's new line provides a wide variety of nozzles, bases, and mounting hardware to accomplish these functions in a simple, cost-effective way. By selecting the

appropriate orifice size, the nozzle can deliver anywhere from a large blast to a small pin-point stream of air, water, or oil. Nozzles can be easily aimed and locked into position for precise delivery of air or liquid. Nozzle tubes are interchangeable.

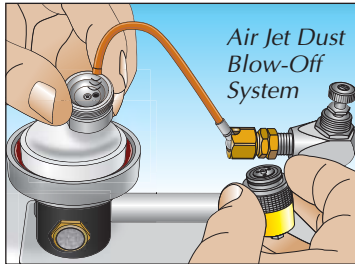

**Medium:** Air, gases, water, compatible cooling fluids

**Materials:** Corrosion-resistant brass and stainless steel

**Ports:** #10-32 male, #10-32 female, 1/8-27 NPT

**Pressure Range:** Up to 200 psig

**Mounting:** Mounting squeeze block, direct-mount

**Temperature Range:** 32 to 180°F (0 to 82°C)

**Nozzle Tube I.D.s**

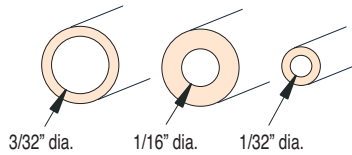

Blank ball nozzles are available to allow customers to install their own special nozzle tubes. Consult Clippard with requirements.

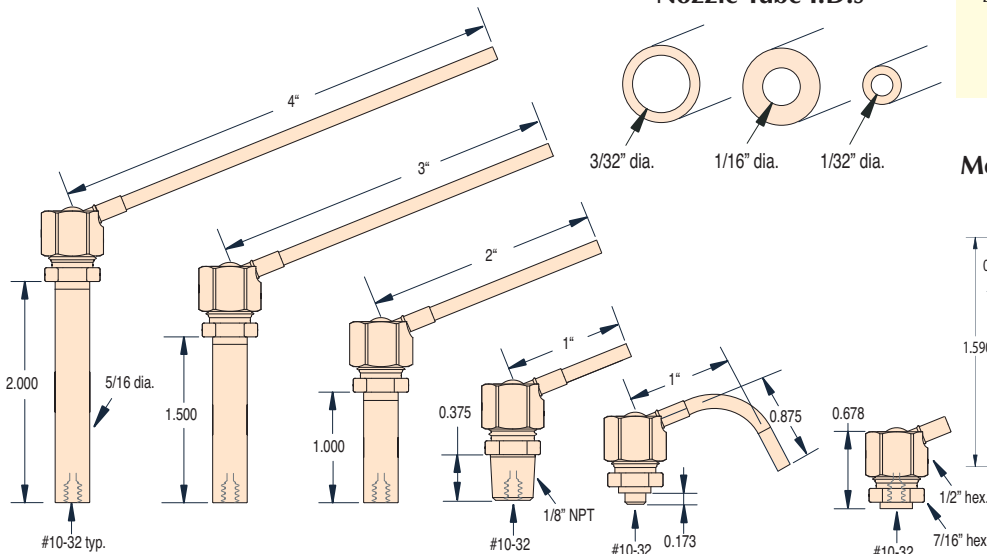

**Mounting Squeeze Block**

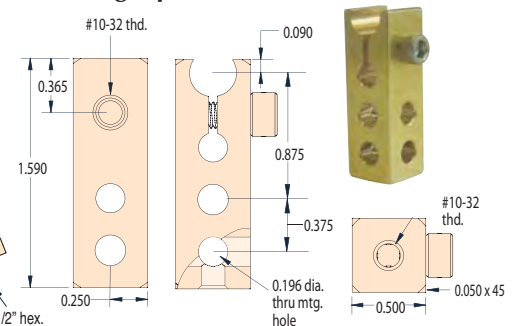





For the ultimate in convenience, have a selection of helpful fittings available for every need. Keeping a supply of fittings on hand can save money and time, allowing projects, prototypes, circuits, and repairs to be finished quickly and avoiding delays.

These Minimatic fittings kits contain a variety of the most commonly used fittings and quick connects. The kit saves time ordering and additional parts or replacements can be ordered at any time. Each kit comes in a sturdy plastic case.



## Minimatic Slip-On Fittings Kit



- UT0-FOF Universal Tee #10-32M to #10-32F
- UT0-F Universal Elbow #10-32M to #10-32F
- UTF-F Universal Tee #10-32M to #10-32F
- UTF-FOF Universal Cross #10-32M to #10-32F
- In-Line Connectors
  - C44 1/8" I.D. Hose to 1/8" I.D. Hose
  - C42 1/8" I.D. Hose to 1/16" I.D. Hose
  - C22 1/16" I.D. Hose to 1/16" I.D. Hose
- T22-4 1/8" I.D. Hose Tee to 1/16" I.D. Hose
- T44-2 1/16" I.D. Hose Tee to 1/8" I.D. Hose
- X44-404 1/8" I.D. Hose Cross
- X22-202 1/16" I.D. Hose Cross
- SP0-4 1/8" MNPT to Elbow 1/8" I.D. Hose
- SP0-2 1/8" MNPT to Elbow 1/16" I.D. Hose
- SP0-4004 1/8" MNPT to Tee 1/8" I.D. Hose
- SP0-2002 1/8" MNPT to Tee 1/16" I.D. Hose
- T22-2 1/16" I.D. Hose Tee
- T44-4 1/8" I.D. Hose Tee
- XT4-404 1/8" I.D. Hose Cross with #10-32M
- XT2-202 1/16" I.D. Hose Cross with #10-32M
- CT2 1/16" I.D. Hose to #10-32M
- CT4 1/8" I.D. Hose to #10-32M
- Inline Swivel Connectors
  - S44 1/8" I.D. Hose to 1/8" I.D. Hose
  - ST4 1/8" I.D. Hose to #10-32M
  - S4F 1/8" I.D. Hose to #10-32F

### Contains:

- CT0-2 Connector Elbow 1/16" I.D. Hose to #10-32M
- UT0-2 Universal Elbow 1/16" I.D. Hose to #10-32M
- ST0-2 Swivel Elbow 1/16" I.D. Hose to #10-32M
- CT0-4 Connector Elbow 1/8" I.D. Hose to #10-32M
- UT0-4 Universal Elbow 1/8" I.D. Hose to #10-32M
- ST0-4 Swivel Elbow 1/8" I.D. Hose to #10-32M
- TT0-202 Connector 1/16" I.D. Hose Tee with #10-32M
- UT0-2002 Universal 1/16" I.D. Hose Tee with #10-32M
- ST0-2002 Swivel 1/16" I.D. Hose Tee with #10-32M
- TT0-404 Connector 1/8" I.D. Hose Tee with #10-32M
- UT0-4004 Universal 1/8" I.D. Hose Tee with #10-32M
- ST0-4004 Swivel 1/8" I.D. Hose Tee with #10-32M
- 11770 Clippard 1/4" & 5/16" Wrench 11770
- 11761-2 Gasket
- Hose Samples

Part No.	Description
<u>17555-SF1</u>	Slip-On Fittings Kit

## Minimatic Fittings Kit



### Contains:

- 1/8" NPT to #10-32 Elbow 15090-1
- #10-32 Elbow Fitting 15002-2
- #10-32 Screw Plug 11755
- #10-32 to 1/16" I.D. Hose Fitting 11752-2

- #10-32 Extension Fitting 15010
- 1/8" MNPT to 1/8" I.D. Hose Adapter 11924-1
- Adjustable #10-32 Elbow Fitting 15002-1
- #10-32 Cross Fitting 15002-4
- Female #10-32 Hex Connector 15004
- #10-32M to 1/8" I.D. Hose with Swivel 15045
- 1/4" MNPT to #10-32F Adapter 4CQF
- 1/8" NPT to #10-32 Tee 15090-2
- #10-32 Tee Fitting 15002-3
- #10-32M Short Coupling 11999
- #10-32 to 1/8" I.D. Hose Fitting 11752-3
- Gasket 11761-2
- 12-Port Manifold MAN-12
- 1/4" & 5/16" Wrench 11770
- 1/8" MNPT to #10-32F Adapter 2CPF

Part No.	Description
17555	Minimatic Fittings Kit

## Minimatic Quick Connect Fittings Kit



### Contains:

- 1/8" I.D. Tee Connector T44-4
- Panel Mount #10-32F Cap MJQC-CPF
- Panel Mount 1/8" I.D. Hose Cap MJQC-CPB

- 3/8-24 Nuts 0107-48
- Lockwasher 0302-43
- 1/8" NPTF Valve MJQC-VFP
- 1/4" NPTM Valve MJQC-VMQ
- 1/8" NPTM Valve MJQC-VMP
- 1/8" NPTM Cap MJQC-CMP
- 1/4" NPTM Cap MJQC-CMQ
- 1/8" I.D. Hose Valve MJQC-VB4
- Panel Mount #10-32F Valve MJQC-VFT
- Panel Mount #10-32M Valve MJQC-VMT
- #10-32F Cap MJQC-CFT
- 1/8" I.D. Hose Cap MJQC-CB4
- Gasket 11761-2
- Hose Samples
- 1/4" & 5/16" Wrench 11770
- #10-32M to 1/8" I.D. CT4
- UTO-4 UTO-4004

Part No.	Description
17555-QC1	Quick Connect Fittings Kit





## 1/8" O.D. Copper Tubing

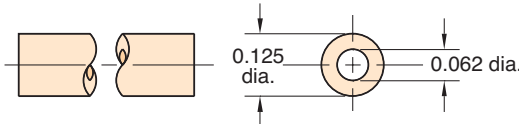
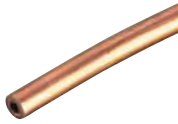

**Part No.** **Description**  
[3811-1-RL](#) Copper Tubing

**Material:** High pressure copper  
**Working Pressures:** to 2,500 psig  
**Static Burst Pressure:** over 10,000 psig  
**Lengths Available:** 50'  
**Bend Radius:** 3/8"  
**Use With:** Ferrule tubing connectors: [3810-1](#), [3810-2](#), [11923](#)

## 3/32" I.D. Nylon Tubing

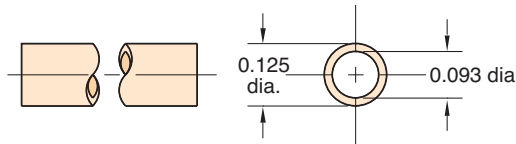

**Part No.**  
[NYT1-0403-CLT-□](#)

**Material:** Semi-flexible nylon tubing  
**Color:** Clear / Translucent  
**Working Range:** to 250 psig  
**Static Burst Pressure:** Approx. 1,000 psig  
**Use With:** Ferrule tubing connectors: [11923](#), [3810-1](#), [3810-2](#)  
**Forming:** May be formed into sharp corners with heat  
**Lengths Available:** 50' and 500'  
**Bend Radius:** 3/8"

## 1/16" I.D. 80A Vinyl Hose

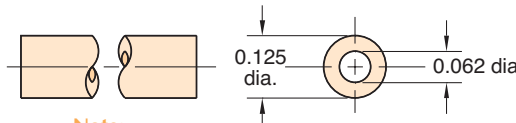

**Part No.**  
[VYH1-0402-CLT-□](#)

**Note:**  
 Consult factory for custom colors

**Type:** Flexible, durable vinyl plastic hose  
**Working Range:** 0 to 105 psig at 70°F maximum 60 psig at 80°F or above (max. temp. 100°F)  
**Use With:** Hose fittings: [11752-2](#) and clamp [5000-4](#)  
**Bend Radius:** 3x hose dia.  
**Color:** Translucent: Clear  
**Lengths Available:** 50' and 500'  
**Bend Radius:** 3/8"

## 1/8" I.D. 80A Vinyl Hose

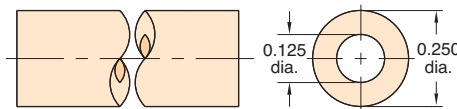

**Part No.**  
[VYH1-0804-CLT-□](#)

**Note:**  
 Consult factory for custom colors

**Working Range:** 0 to 105 psig at 70°F maximum 60 psig at 80°F or above (max. temp. 100°F)  
**Use With:** Hose fittings: [11752-1](#), [11752-3](#) and [11924](#)  
 Hose clamps: [5000-2](#)  
**Bend Radius:** 3x hose dia.  
**Color:** Translucent: Clear  
**Lengths Available:** 50' and 500'  
**Bend Radius:** 1/2"

## 1/8" I.D. Twin Vinyl Hose

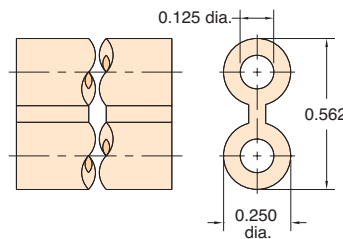

**Part No.**  
[VYH2-0804-GYS-□](#)

**Type:** Flexible, durable vinyl plastic hose, but two hoses molded together, one side has rib entire length for identification  
**Color:** Solid: Gray/Gray  
**Use Clamp:** [5000-1](#)  
**Working Range:** 0 to 150 psig at 70°F maximum 60 psig at 80°F or above (max. temp. 100°F)  
**Use:** Ideal for feeding supply in on one line and out on the other, reduces labor; makes neat assembly; may be parted with any sharp cutting edge  
**Lengths Available:** 50' and 500'  
**Bend Radius:** 1/2"

## 1/16" I.D. 85A Polyurethane Hose

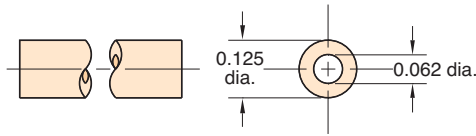

**Working Range:** 0 to 105 psig at 100°F Maximum 120°F

**Static Burst Pressure:** Over 500 psig at 70°F

**Color:** Solid: Black, brown, white, gray, orange  
Translucent: Clear, blue, green, red, yellow

**Lengths Available:** 50' and 500'

**Bend Radius:** 3/16"

**Note:** In normal application hose clamps are not required with hose when used with Clippard hose barb fittings

**Part No.**

[URH1-0402-□□](#)

**Note:**

Specify color on order, and use full product number (including code letters for color) as shown in Price List. If no color is specified, clear will be furnished.

## 1/16" I.D. 85A Polyurethane Ribbon Hose

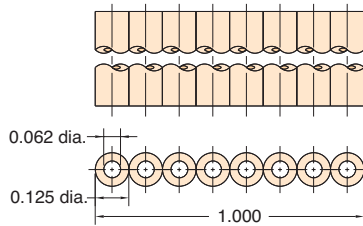
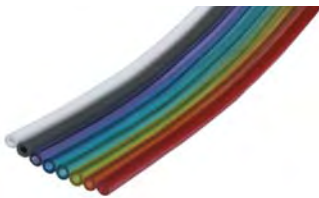

**Type:** Flexible, durable urethane hose

**Working Range:** 0 to 105 psig at 100°F maximum 120°F

**Static Burst Pressure:** Over 500 psig at 70°F

**Color:** Solid: Gray, white  
Translucent: Blue, green, orange, purple, red, yellow

**Lengths Available:** 50'

**Bend Radius:** 3/16"

**Note:** In normal application, hose clamps are not required with hose when used with Clippard hose barb fittings

**Part No.**

[URH8-0402-02T-050](#)

## 1/8" I.D. 85A Polyurethane Hose

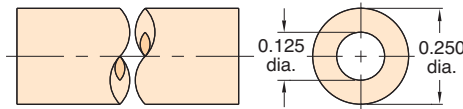

**Working Range:** 0 to 105 psig at 100°F Maximum 120°F

**Static Burst Pressure:** Approximately 425 psig at 70°F

**Color:** Solid: Black, brown, white, gray, orange  
Translucent: Clear, blue, green, red, yellow

**Lengths Available:** 50' and 500'

**Bend Radius:** 3/8"

**Note:** In normal application hose clamps are not required with hose when used with Clippard hose barb fittings

**Part No.**

[URH1-0804-□□](#)

**Note:**

Specify color on order, and use full product number (including code letters for color) as shown in Price List. If no color is specified, clear will be furnished.

## Twin 1/8" I.D. 85A Polyurethane Hose

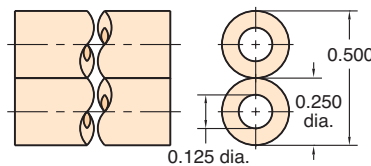

**Working Range:** 0 to 105 psig at 100°F

**Static Burst Pressure:** Approximately 425 psig at 70°F

**Color:** Solid: Gray and black combination

**Lengths Available:** 50' and 500'

**Bend Radius:** 3/8"

**Use:** Ideal for feeding supply in on one line and out on the other; reduces labor; makes neat assembly; may be parted with any sharp cutting edge

**Note:** In normal application, hose clamps are not required with URH2-0804-01S hose when used with Clippard hose barb fittings

**Part No.**

[URH2-0804-01S-□](#)

## 1/8" I.D. 85A Polyurethane Ribbon Hose

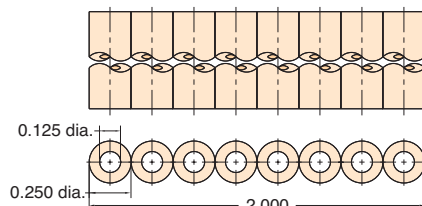
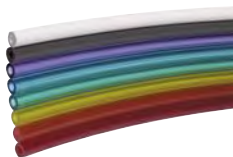

**Type:** Flexible, durable urethane hose

**Working Range:** 0 to 105 psig at 100°F maximum 120°F

**Static Burst Pressure:** Over 500 psig at 70°F

**Color:** Solid: Gray, white  
Translucent: Blue, green, orange, purple, red, yellow

**Lengths Available:** 50'

**Bend Radius:** 3/8"

**Note:** In normal application, hose clamps are not required with hose when used with Clippard hose barb fittings

**Part No.**

[URH8-0804-02T-050](#)



### 5/32" O.D. 95A Polyurethane Tubing

Flexible, durable ether based tubing

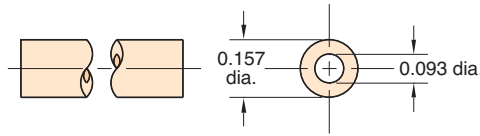

**Part No.**

URT1-0503-□□

**Note:**

Specify color on order, and use full product number (including code letters for color) as shown in Price List. If no color is specified, clear will be furnished.

**Working Range:** 0 to 105 psig at 100°F Maximum 120°F

**Static Burst Pressure:** Over 500 psig at 70°F

**Color:** Solid: Black, gray, orange, red, white  
Translucent: Blue, clear, green, red, yellow

**Lengths Available:** 50' and 500'

**Bend Radius:** 3/8"

**Note:** Designed for use with push-in fittings.

### 6 mm O.D. 95A Polyurethane Tubing

Flexible, durable ether based tubing

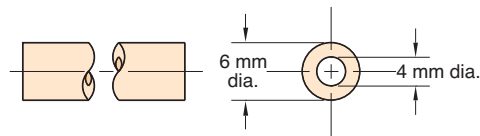

**Part No.**

URT1-0604M-□□

**Note:**

Specify color on order, and use full product number (including code letters for color) as shown in Price List. If no color is specified, clear will be furnished.

**Working Range:** 0 to 105 psig at 100°F Maximum 120°F

**Static Burst Pressure:** Over 450 psig at 70°F

**Color:** Solid: Black  
Translucent: Blue, clear, green, red

**Lengths Available:** 50' and 500'

**Bend Radius:** 1/2"

**Note:** Designed for use with push-in fittings.

### 1/4" O.D. 95A Polyurethane Tubing

Flexible, durable ether based tubing

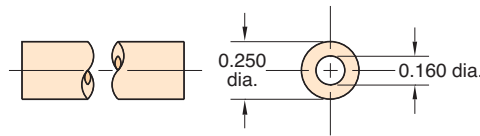

**Part No.**

URT1-0805-□□

**Note:**

Specify color on order, and use full product number (including code letters for color) as shown in Price List. If no color is specified, clear will be furnished.

**Working Range:** 0 to 105 psig at 100°F Maximum 120°F

**Static Burst Pressure:** Over 450 psig at 70°F

**Color:** Solid: Black, gray, orange, red, white  
Translucent: Blue, clear, green, red, yellow

**Lengths Available:** 50' and 500'

**Bend Radius:** 1/2"

**Note:** Designed for use with push-in fittings.

### 8 mm O.D. 95A Polyurethane Tubing

Flexible, durable ether based tubing

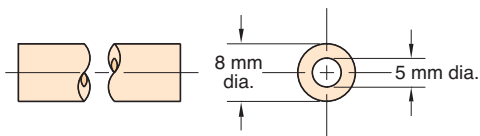

**Part No.**

URT1-0805M-CLT-□

**Working Range:** 0 to 105 psig at 100°F Maximum 120°F

**Static Burst Pressure:** Over 465 psig at 75°F

**Color:** Clear

**Lengths Available:** 50' and 500'

**Bend Radius:** 3/4"

**Note:** Designed for use with push-in fittings.

### 3/8" O.D. 95A Polyurethane Tubing

Flexible, durable ether based tubing

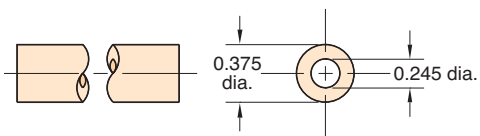

**Part No.**

URT1-1208-□□

**Note:**

Specify color on order, and use full product number (including code letters for color) as shown in Price List. If no color is specified, clear will be furnished.

**Working Range:** 0 to 105 psig at 100°F Maximum 120°F

**Static Burst Pressure:** Over 440 psig at 75°F

**Color:** Solid: Black  
Translucent: Blue, clear, green, red

**Lengths Available:** 50' and 500'

**Bend Radius:** 7/8"

**Note:** Designed for use with push-in fittings.

## 1/2" O.D. 95A Polyurethane Tubing

Flexible, durable ether based tubing

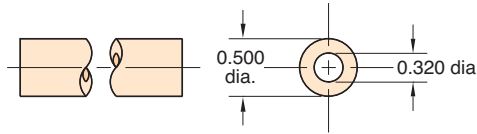

**Part No.**

URT1-1610-CLT-□

**Working Range:** 0 to 105 psig at 100°F Maximum 120°F

**Static Burst Pressure:** Over 420 psig at 75°F

**Color:** Clear

**Lengths Available:** 50' and 250'

**Bend Radius:** 1 1/8"

**Note:** Designed for use with push-in fittings.

## 5/32" O.D. 50D Polyethylene Tubing

Linear low density tubing

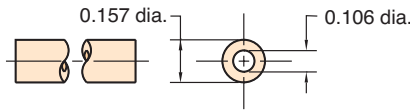

**Part No.**

PET1-0503-□-□

**Note:**

Specify color on order, and use full product number (including code letters for color) as shown in Price List. If no color is specified, natural will be furnished.

**Working Range:** 0 to 105 psig at 100°F Maximum 120°F

**Static Burst Pressure:** Over 540 psig at 75°F

**Colors:** Solid: Black or Natural

**Lengths Available:** 50' and 500'

**Bend Radius:** 1/2"

**Note:** Designed for use with push-in fittings.

## 6 mm O.D. 50D Polyethylene Tubing

Linear low density tubing

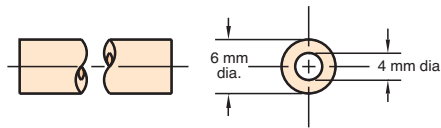

**Part No.**

PET1-0604M-□-□

**Note:**

Specify color on order, and use full product number (including code letters for color) as shown in Price List. If no color is specified, natural will be furnished.

**Working Range:** 0 to 105 psig at 100°F Maximum 120°F

**Static Burst Pressure:** Approximately 560 psig at 75°F

**Colors:** Solid: Black or Natural

**Lengths Available:** 50' and 500'

**Bend Radius:** 1 1/4"

**Note:** Designed for use with push-in fittings.

## 1/4" O.D. 50D Polyethylene Tubing

Linear low density tubing

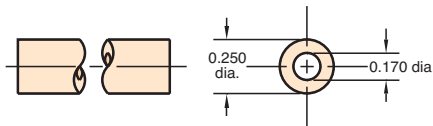

**Part No.**

PET1-0805-□-□

**Note:**

Specify color on order, and use full product number (including code letters for color) as shown in Price List. If no color is specified, natural will be furnished.

**Working Range:** 0 to 105 psig at 100°F Maximum 120°F

**Static Burst Pressure:** Approximately 480 psig at 75°F

**Colors:** Solid: Black or Natural

**Lengths Available:** 50' and 500'

**Bend Radius:** 1 1/4"

**Note:** Designed for use with push-in fittings.

## 3/8" O.D. 50D Polyethylene Tubing

Linear low density tubing

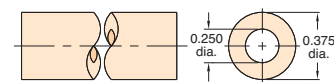

**Part No.**

PET1-1208-□-□

**Note:**

Specify color on order, and use full product number (including code letters for color) as shown in Price List. If no color is specified, natural will be furnished.

**Working Range:** 0 to 105 psig at 100°F Maximum 120°F

**Static Burst Pressure:** Approximately 600 psig at 75°F

**Colors:** Solid: Black or Natural

**Lengths Available:** 50' and 500'

**Bend Radius:** 2"

**Note:** Designed for use with push-in fittings.

### Quick Set Hose Clamp



**Type:** Zinc plated steel  
**Use:** 5000-1 with twin vinyl hose

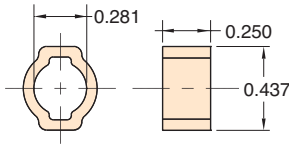

**Part No.** **Description**  
5000-1 Hose Clamp

### Quick Set Hose Clamp



**Type:** Zinc plated steel

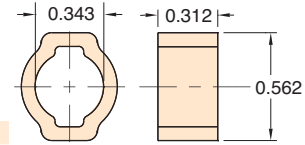

**Part No.** **Description**  
5000-1A Hose Clamp

### Reusable Hose Clamp

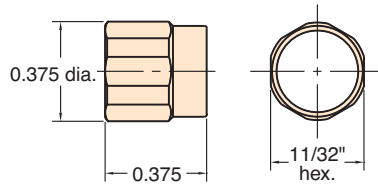

**Part No.** **Description**  
5000-2 Hose Clamp

**Material:** Brass, self-threading, reusable

**Use With:** 11765 Nitrile hose VYH1-0804-CLT vinyl hose and Clippard hose fittings

**Installation:** Slip sleeve over hose, push onto fitting, then screw into place; tighten with wrench

**Options:** (-ENP)



### Press-On Hose Clamp

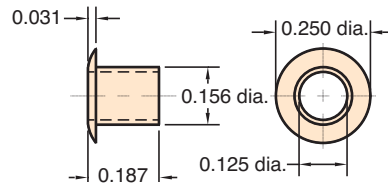

**Part No.** **Description**  
5000-4 Hose Clamp

**Material:** Brass, press-on hose clamp

**Use:** for VYH1-0402-CLT hose 1/16" I.D. vinyl

**Installation:** Simply place hose clamp over hose with flange end out; then press hose partially onto fitting, then slide clamp back toward fitting to secure

**Options:** (-ENP)



### Polyethylene vs. Vinyl vs. Polyurethane

Polyurethane offers a wider range of chemical compatibility than Vinyl, it may be used at much higher temperatures and clamps are not needed when used with barb fittings. Linear low density polyethylene offers a lower cost alternative to polyurethane and superior environmental stress crack resistance over standard polyethylene. Both polyurethane and polyethylene are FDA approved.

### Typical Hose & Tubing Bend Radii

When using hose or tubing, care should always be taken to avoid sharp bends to prevent compressing the inside diameter of the hose or tubing and restricting flow. For extremely close connections, allow a short loop of hose to avoid crimping.

Clippard Hose & Tubing		I.D.	O.D.	Min. Bend Radius
3811-1-RL	Copper Tube	1/16"	1/8"	3/8"
NYT1-XXX	Nylon Tubing	3/32"	1/8"	3/8"
VYH1-XXX	80A Duro. Vinyl Hose	1/16"	1/8"	3/8"
VYH1-XXX	80A Duro. Vinyl Hose	1/8"	1/4"	1/2"
VYH2-XXX	Dual Vinyl Hose	1/8"	1/4"	1/2"
URH1-XXX	85A Duro. Polyurethane Hose	1/16"	1/8"	3/16"
URH8-XXX	Ribbon 85A Duro. Polyurethane	1/16"	1/8"	3/16"
URH1-XXX	85A Duro. Polyurethane Hose	1/8"	1/4"	3/8"
URH2-XXX	Dual 85A Duro. Polyurethane	1/8"	1/4"	3/8"
URH8-0804-XXX	Ribbon 85A Duro. Polyurethane	1/8"	1/4"	3/8"
URT1-0503-XXX	95A Duro. Polyurethane Tubing	3/32"	5/32"	3/8"
URT1-0604M-XXX	95A Duro. Polyurethane Tubing	4 mm	6 mm	1/2"
URT1-0805-XXX	95A Duro. Polyurethane Tubing	0.160"	1/4"	1/2"
URT1-0805M-CLT	95A Duro. Polyurethane Tubing	5 mm	8 mm	3/4"
URT1-1208-XXX	95A Duro. Polyurethane Tubing	0.245"	3/8"	7/8"
URT1-1610-XXX	95A Duro. Polyurethane Tubing	0.320"	1/2"	1 1/8"
PET1-0503-XXX	50D Duro. Polyethylene Tubing	0.106"	5/32"	1/2"
PET1-0604M-XXX	50D Duro. Polyethylene Tubing	4 mm	6 mm	1 1/4"
PET1-0805-XXX	50D Duro. Polyethylene Tubing	0.170"	1/4"	1 1/4"
PET1-1208-XXX	50D Duro. Polyethylene Tubing	1/4"	3/8"	2"