

MULTI-SPINDLE HEADS

MULTI-SPINDLE HEADS

Ahead is information on the range of multi-spindle heads available from E2. Multi-spindle heads enable tools to be closer together than with separate units, and all holes can be worked simultaneously without having to control numerous units.

Most hole patterns are symmetrical and therefore ideal for using adjustable multi-spindle heads. It is also often possible to produce non-symmetrical patterns using these. E2 offers assistance in checking the feasibility of using an adjustable head.

Adjustable multi-spindle heads can be divided into the following four basic types:

- 2-spindle heads
- 3-spindle heads (centre spindle fixed)
- 3-spindle heads (all spindles adjustable)
- 4-spindle heads

When adjustable heads aren't suitable for the pattern to be produced or don't have enough spindles, special heads with fixed spindles can be used. These heads also offer extra precision and high repeatability for operations. All E2 units suitable for adjustable multi-spindle heads can also be fitted with fixed heads. For more information or a quote, contact E2.

PLEASE NOTE

- that multi-spindle heads reduce the idling speed as well as the speed and torque at maximum output for all units with pneumatic spindle drive. The effect on idling speed ranges from -5% for a small 2-spindle head on a low speed BE33 to -30% for a large 3 or 4-spindle head on a high speed BE22. This has been taken into account in the Guidelines in each unit's details.
- when tapping with the BEG 48 or BEG 55 you need length compensation on all spindles. This can be achieved by using collets with float compensation or tapping spindles. See Tool Holders (page 52) for more information.

MULTI-SPINDLE HEADS

DIMENSIONS FOR E2 MULTI-SPINDLE HEADS

This first section, with information on E2's range of multi-spindle heads, is followed by a section showing specifications of feasible head and unit combinations for drilling and tapping. Other combinations are possible for special applications like counter-sinking, reaming, etc, as well as heads with fixed spindles in patterns according to customer specification. Please contact E2 for further information.

The collets needed for the tool holders on E2's multi-spindle heads are described in more detail in Tool Holders (page 51).



2-SPINDLE HEADS

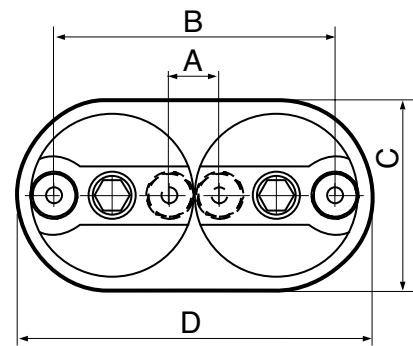

Specifications						
MODEL	MAX CAPACITY IN STEEL		COLLETS FOR MAX Ø [mm]	COLLET TYPE	MAX SPEED [rpm]	WEIGHT EXCL. ADAPTOR [kg]
	DRILLING Ø [mm]	TAPPING [M-threads]				
VH 042P	5	M3	5	ER8	4 000	0.95
VH 062P	7	M5	8	ER11	4 000	1.65
VH 082P	10	M5	12	ER16	4 000	2.20
VH 102P	12	M6	12	ER16	3 500	3.50
VH 132P	14	M6	15	ER20	3 000	5.30
VH 182P	16	M8	16	ER25	2 500	8.30

Dimensions [mm]				
MODEL	A MIN SPINDLE SPACING	B MAX SPINDLE SPACING	C SHORTER SIDE	D LONGER SIDE
VH 042P	12	72	49	91
VH 062P	17	93	65	120
VH 082P	24	108	75	141
VH 102P	28	120	83	157
VH 132P	35	151	102	195
VH 182D	41	173	122	229

3-SPINDLE HEADS (centre spindle fixed)

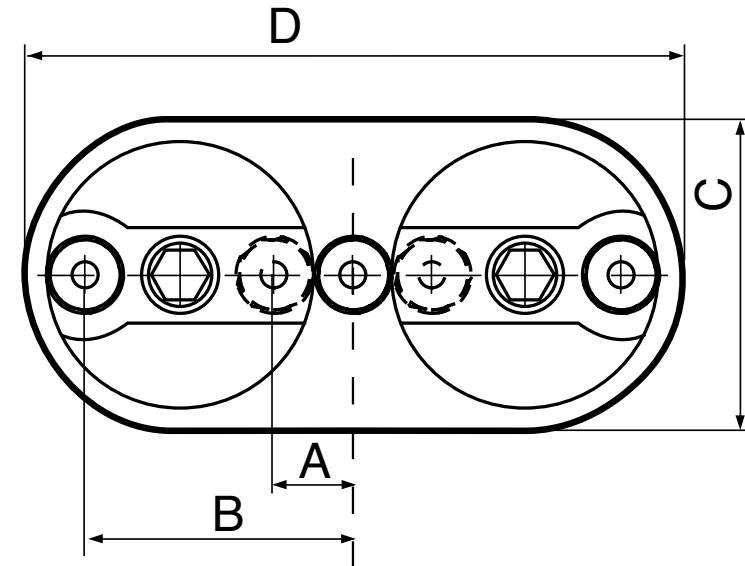

Specifications						
MODEL	MAX CAPACITY IN STEEL		COLLETS FOR MAX Ø [mm]	COLLET TYPE	MAX SPEED [rpm]	WEIGHT EXCL. ADAPTOR [kg]
	DRILLING Ø [mm]	TAPPING [M-threads]				
VH 043LP	5	M3	5	ER8	4 000	1.05
VH 063LP	7	M5	8	ER11	4 000	1.95
VH 083LP	10	M6	12	ER16	4 000	2.90
VH 103LP	12	M8	12	ER16	3 500	4.90
VH 133LP	14	M12	15	ER20	3 000	7.20
VH 183LP	16	M14	16	ER25	2 500	10.75

Dimensions [mm]				
MODEL	A MIN SPINDLE SPACING	B MAX SPINDLE SPACING	C SHORTER SIDE	D LONGER SIDE
VH 043LP	12	42	49	103
VH 063LP	17.5	55.5	65	138
VH 083LP	24	66	75	165
VH 103LP	28	74	87	189
VH 133LP	35	93	102	230
VH 183LD	41	107	122	270

3-SPINDLE HEADS

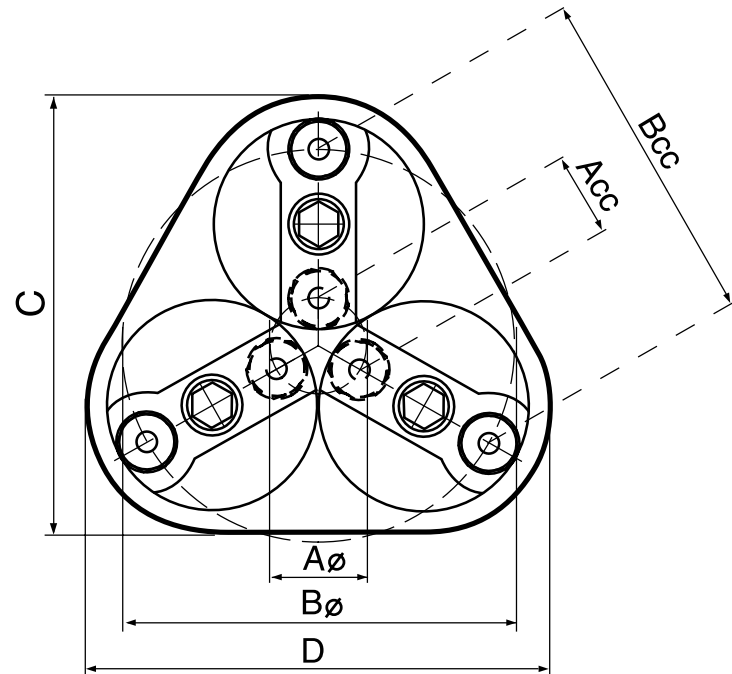

Specifications

MODEL	MAX CAPACITY IN STEEL		COLLETS FOR MAX Ø [mm]	COLLET TYPE	MAX SPEED [rpm]	WEIGHT EXCL. ADAPTOR [kg]
	DRILLING Ø [mm]	TAPPING [M-threads]				
VH 043P	5	M3	5	ER8	4 000	1.4
VH 063P	7	M5	8	ER11	4 000	2.3
VH 083P	10	M6	12	ER16	4 000	3.4
VH 103P	12	M8	12	ER16	3 500	4.9
VH 133P	14	M12	15	ER20	3 000	8.3
VH 183D	20	M14	-	TR28	2 500	12.0

Dimensions

MODEL	A MIN SPINDLE SPACING		B MAX SPINDLE SPACING		C SHORTER SIDE	D LONGER SIDE
	Ø	CC	Ø	CC		
VH 043P	18.5	16	78.5	68	86	91
VH 063P	27	23.5	103	89	113	119
VH 083P	36	32	120	104	134	142
VH 103P	40	35	132	115	148	157
VH 133P	51	44.5	167	144	184	195
VH 183D	59	52	191	165	216	229

4-SPINDLE HEADS

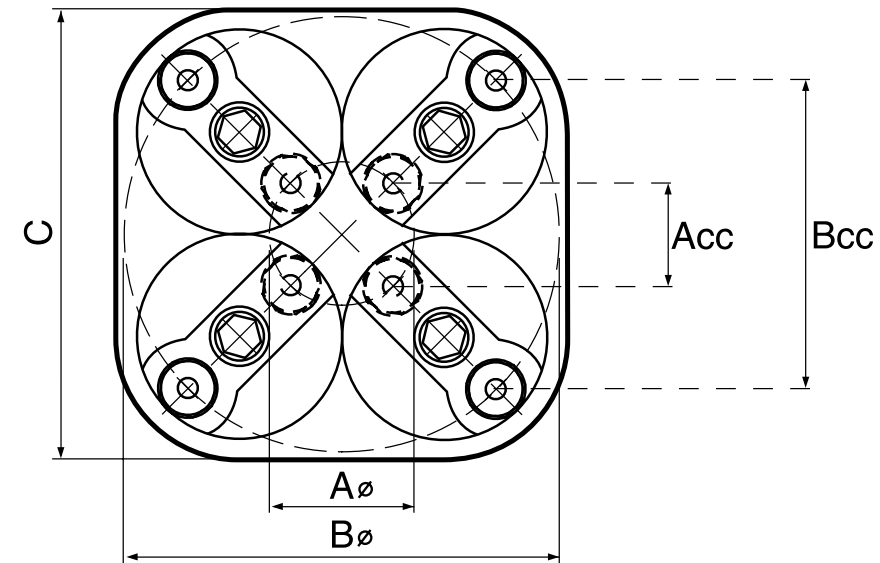

Specifications

MODEL	MAX CAPACITY IN STEEL		COLLETS FOR MAX Ø [mm]	COLLET TYPE	MAX SPEED [rpm]	WEIGHT EXCL. ADAPTOR [kg]
	DRILLING Ø [mm]	TAPPING [M-threads]				
VH 044P	5	M3	5	ER8	4 000	1.9
VH 064P	7	M5	8	ER11	4 000	3.1
VH 084P	10	M6	12	ER16	4 000	4.6
VH 104P	12	M8	12	ER16	3 500	7.2
VH 134P	14	M12	15	ER20	3 000	10.8
VH184D	20	M14	-	TR28	2 500	15.8

Dimensions

MODEL	A MIN SPINDLE SPACING		B MAX SPINDLE SPACING		C SIDE
	Ø	CC	Ø	CC	
VH 044P	29.5	21	89.5	63	91
VH 064P	41	29	117.5	82.5	119
VH 084P	53.5	38	137.5	97	142
VH 104P	60	42.5	152	107	158
VH 134P	75	53	191	135	196
VH 184D	86	61	218	154	230

MULTI-SPINDLE HEADS

DIMENSIONS FOR E2 UNITS WITH MULTI-SPINDLE HEADS

Below are specifications of the feasible head and unit combinations for drilling and tapping. Please also check out www.e2systems.com for CAD drawings and models of units with multi-spindle heads.

BE 22 SK and BE 33 SK

Dimensions [mm]				
MODEL	A	B	C	D
VH 042P / 043P / 043LP / 044P	22	25	97	50
VH 062P / 063P / 063LP / 064P	25	34	136	50
VH 082P / 083P / 083LP / 084P	28	40	148	50

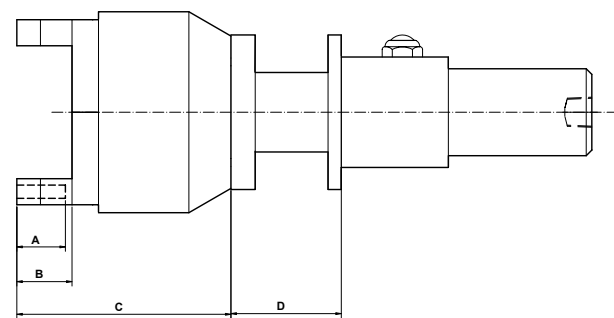

ADAPTOR WEIGHT 0.3 KG

BE(F) 22

Dimensions [mm]				
MODEL	A	B	C	D
VH 042P / 043P / 043LP / 044P	22	25	97	13
VH 062P / 063P / 063LP / 064P	25	34	136	14

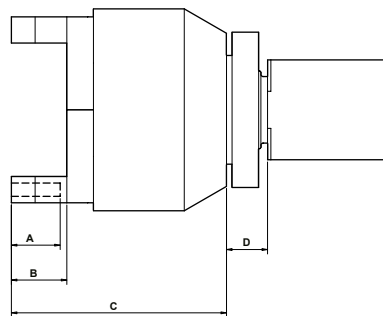

ADAPTOR WEIGHT 0.2 KG

BE 33

Dimensions [mm]				
MODEL	A	B	C	D
VH 042P / 043P / 043LP / 044P	22	25	97	13
VH 062P / 063P / 063LP / 064P	25	34	136	14
VH 082P / 083P / 083LP / 084P	28	40	148	14

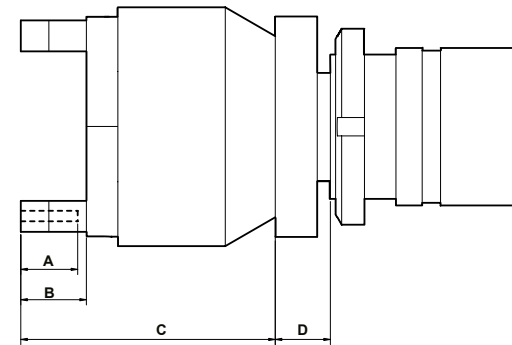

ADAPTOR WEIGHT 0.5-1.5 KG

BE 48 and BEG 48

Dimensions [mm]				
MODEL	A	B	C	D
VH 042P / 043P / 043LP / 044P	22	25	97	98
VH 062P / 063P / 063LP / 064P	25	34	136	98
VH 082P / 083P / 083LP / 084P	28	40	148	98
VH 102P / 103P / 103LP / 104P	28	40	162	104

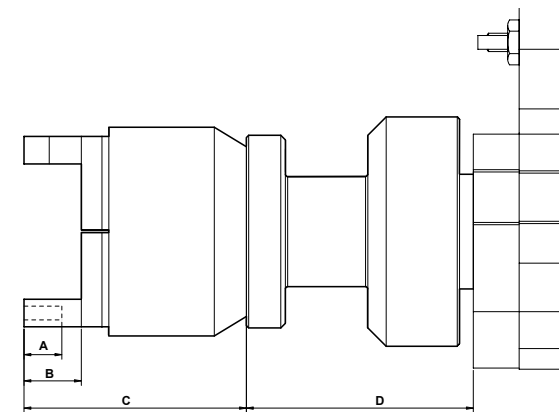

ADAPTOR WEIGHT 1.2 KG

BE 55 and BEG 55

Dimensions [mm]				
MODEL	A	B	C	D
VH 062P / 063P / 063LP / 064P	25	34	136	63
VH 082P / 083P / 083LP / 084P	28	40	148	63
VH 102P / 103P / 103LP / 104P	28	40	162	68
VH 132P / 133P / 133LP / 134P	28	55	174	72
VH 182 / 183 / 183L / 184	-	94	225	68

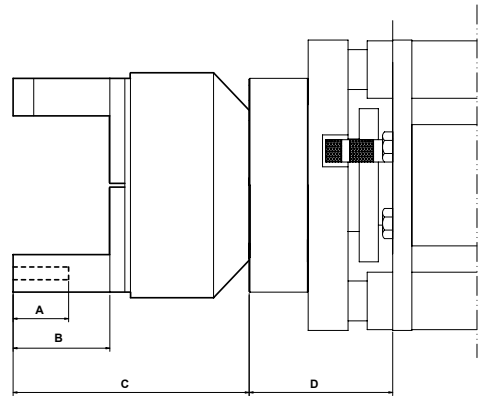

ADAPTOR WEIGHT 3.1 KG

LS 22

Dimensions [mm]			
MODEL	A	B	C
VH 042	22	25	97

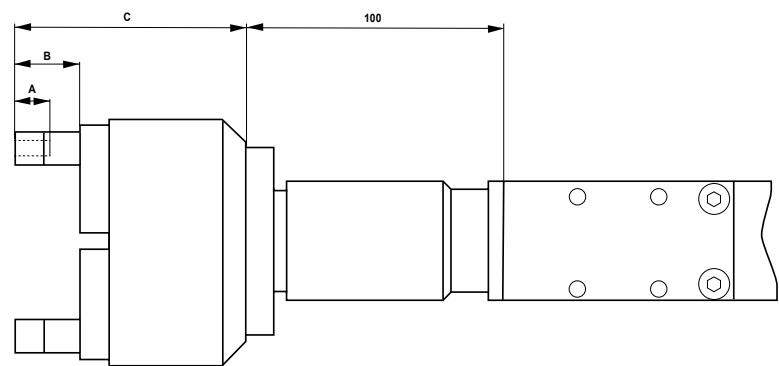

ADAPTOR WEIGHT 1.1 KG

TOOL HOLDERS

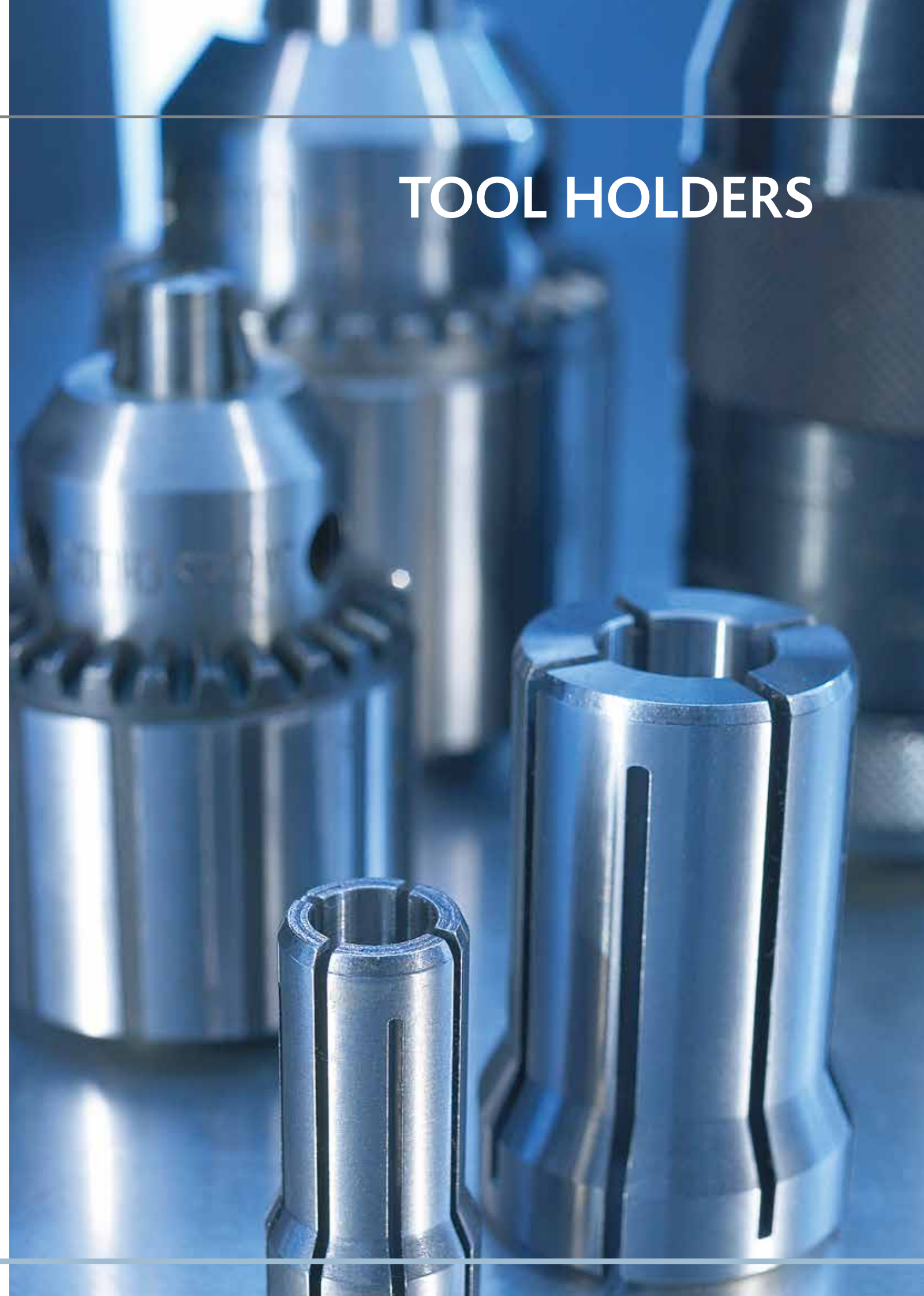

TOOL HOLDERS

All E2 units are delivered ready for tools. E2 has selected a cost-effective tool holding solution for each unit, but if the application requires other holding tools, E2 offers a wide range of options.

FOR DRILLING, E2 OFFERS

- KEY CHUCKS
- DRILL CHUCKS
- PRECISION CHUCKS
- COLLET CHUCKS AND COLLETS

FOR TAPPING, E2 OFFERS

- QUICK-CHANGE CHUCK WITH TAP HOLDERS
- COLLETS WITH LENGTH COMPENSATION
- TAPPING SPINDLES WITH LENGTH COMPENSATION AND TAP HOLDERS



DRILLING

Key chucks

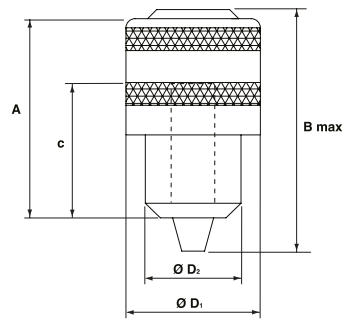

Dimensions [mm]					
KEY CHUCKS	A	B	C	D1	D2
0.5-6.5 3/8"-24	42.5	53	17	29.5	21
0.8-10.0 3/8"-24	49.5	61	24.5	34	24.5

Drill chucks

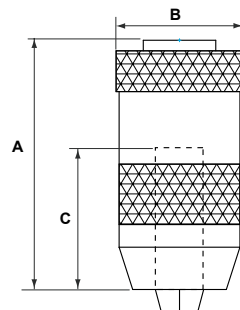

Dimensions [mm]			
DRILL CHUCKS	A	B	C
0-10.0 JT2	83	ø42.5	20-31
3.0-16.0 JT2	95	ø46	20-39

When it's time to change tools, many people prefer using self-tightening keyless chucks for rapid tool changing.

DRILLING

Precision chucks

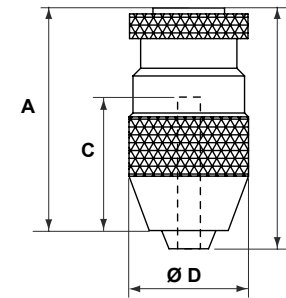

Dimensions [mm]				
PRECISION CHUCKS	A	B	C	D
0-3.0 B10	44	47.5	ca 11-15	ø24
0-5.0 B10	56	61.5	ca 12-18	ø30
0-8.0 B10	69	77.5	ca 16-24	ø38

The E2 selection of precision chucks has been chosen to maintain the unit's precision as far as possible right through to the tool. Keyless self-tightening chucks as well as collet chucks are available.

Collet chucks and Collets

Collet chuck systems offer more reliable clamping with regard to repeatability plus precision and clamping force.

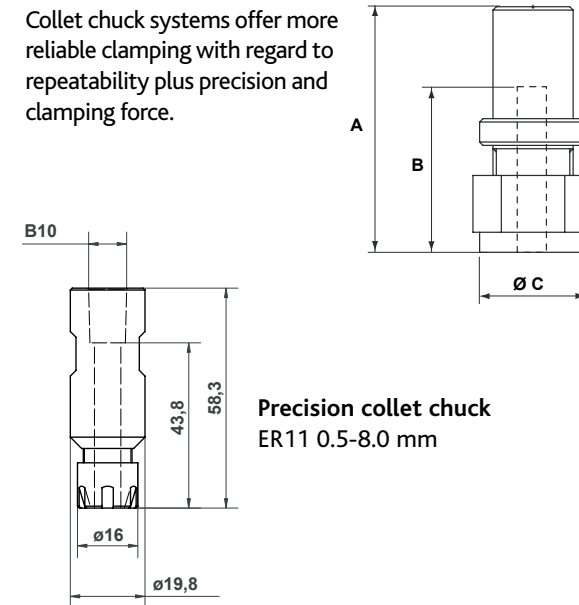

Dimensions [mm]			
COLLET CHUCKS	A	B	C
1.0-10.0 DA200 3/8"-24	49	ø36	ø20.5
3.0-20.0 DA180 3/8"-24	63	ø46.5	ø43.5
2.0-14.0 DA100 JT2	71	ø48	ø36.5
3.0-20.0 DA 180 MT2	63	ø46.5	38

Here we present the specifications of collets for the above chucks, as well as the integrated tool holders that are used in E2 range of multi-spindle heads.

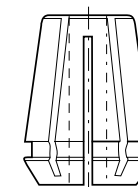

Dimensions [mm]				
COLLETS	NOMINAL		INCREMENTS	CLAMPING RANGE
	Min ø	Max ø		
ER8	1.0	5.0	0.5	-0.5
ER11	1.0	8.0	0.5	-0.5
ER16	1.0	12.0	0.5	-1.0*
ER20	1.0	15.0	0.5	-1.0*
ER32	2.0	20.0	0.5	-1.0

Clamping range -0.8 mm i.e ø 10.0 covers 9.2-10.0 mm
 *ER16 and ER20 Clamping range only 0.5 mm at 1.0 and 1.5 mm nominal diameter
 **0.1 mm up to 10.0 mm diameter

TAPPING

Quick-change chucks with Tap holders

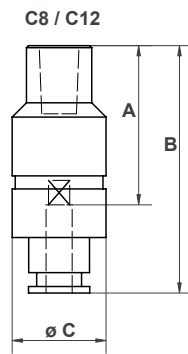
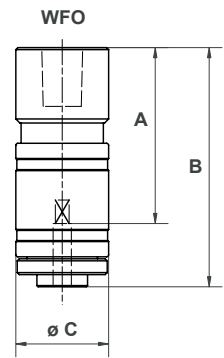

Dimensions [mm]			
CHUCKS	A	B	C
WFO B10	43.4	59.0	ø22.9
WFO B12	46.9	62.5	ø22.9
C8 JT1	39.0	60.6	ø23.0
C12 B12	44-49	64-66	ø30.0

Available in ISO, ANSI and DIN.

Collets with length compensation

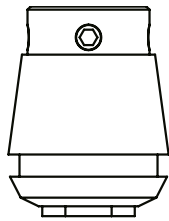

For tapping when relatively short length compensation is required, E2 offers ER collets with expansion compensation suitable for use with E2 units. These can be used in all ER chucks and tool holders (on multi-spindle heads) made for ER collets.

Specifications [mm]					
COLLETS	SHAFT DIAMETER		THREAD SIZE		LENGTH COMPENSATION
	Min ø	Max ø	Min	Max	Max
ER16-ET1 16	1.4	6.3	M0.7	M6	7
ER20-ET1 20	2.2	7.0	M1	M8	7
ER32-ET1 32	4.5	12.5	M4	M12	10

Available in ISO, ANSI and DIN.

Tapping spindles with length compensation and Tap holders

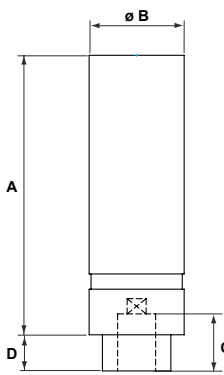

Dimensions [mm]					
TAPPING SPINDLE	A	B	C	D	LENGTH COMPENSATION
GS12E JT2	108-133	ø30	17-20	15-17	25
GS24E B18*	147-187	ø50	30	19-29	40

Available in ISO, ANSI and DIN.

When greater length compensation is required, E2 offers tapping spindles. These tapping attachments provide maximum total length compensation that can be used for expansion, compression or both.

* BEG 48 ER 32 + B18/ø16 taper shank
BEG 55 MT2 + B18/MT2 taper shank

CONTROLS



CONTROLS

E2's units are designed for automation and are simple to connect. The following installation example shows connections and the peripheral equipment required by the units. When installing several pneumatically-operated units, we recommend that each unit have an individual sensor and individual main valves. The wiring circuit show which valves/sensors are integrated into the units.

BE 11 / HFS 100

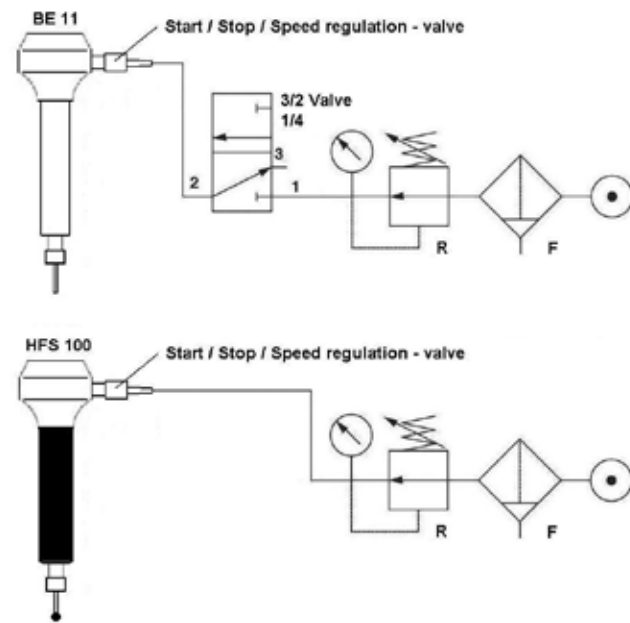

Working Pressure	4-6.3 bar
Air	Clean and dry

BE 22 SK(M) and 33 SK(M)

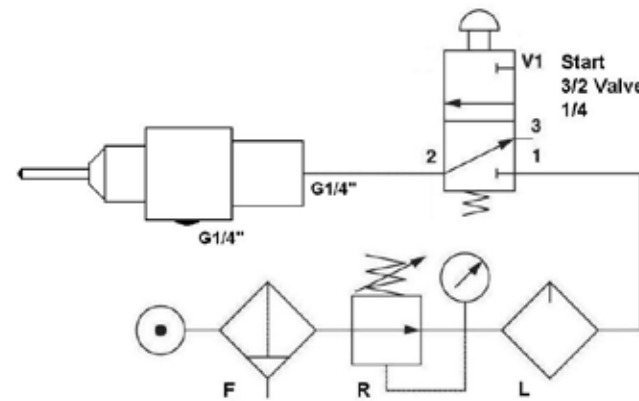

Working Pressure	6-7 bar
Air	Clean, dry and with oil mist (lubrication).
Options	Motor for air with no lubricator. Central silencer

BE(S) 21

Pneumatic limit switches

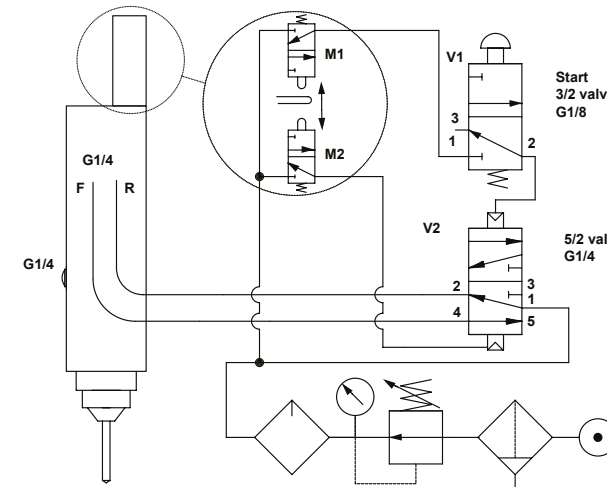

Electric limit switches

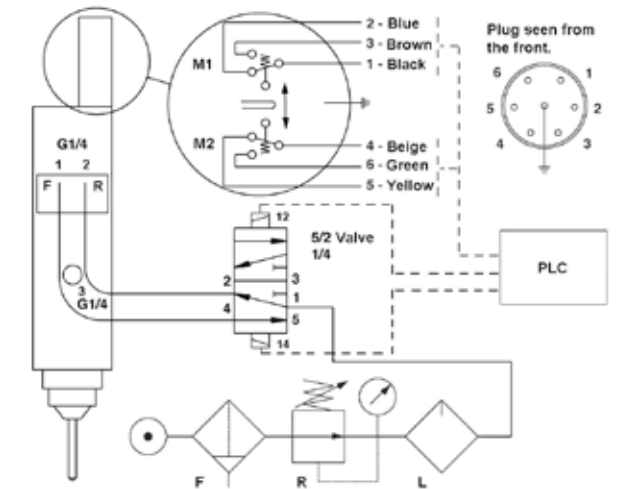

The max load for the switches at 220V is 1A.

The limit switches come with either 1.2 m hose (Pn) or 1.2 m cable (El).

We recommend a delayed return for accurate drilling depth tolerances and for countersinking.

The rotation of the spindle starts when the unit is fed air for forward feed. During the return the rotation gradually slows to a complete stop.

Working Pressure	6-7 bar
Air	Clean, dry and with oil mist (lubrication).
Options	Motor for air with no lubricator. Emergency break valve parallel to M2, which stops the unit and returns it to home position. Central silencer

BE 22 and BE 33

Pneumatic limit switches

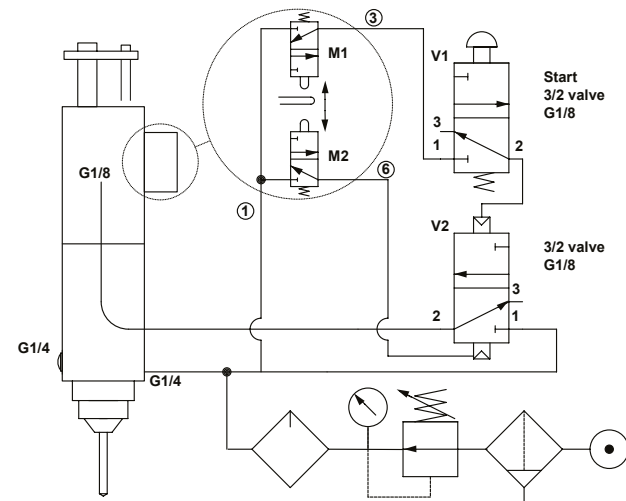

Electric limit switches

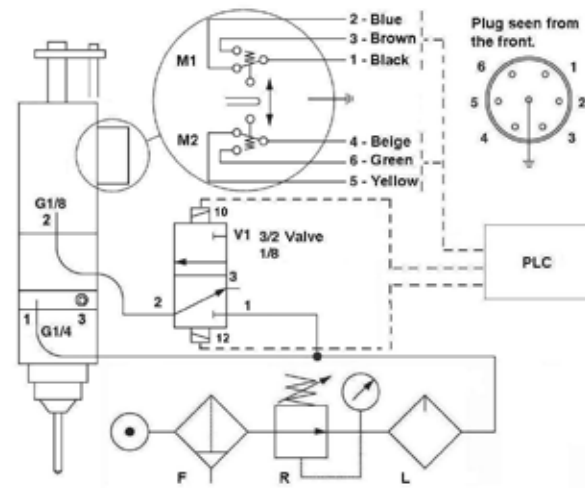

The max load for the switches at 220 V is 1A.

The limit switches comes with either 2 m hose (Pn) or 2 m cable (El).
We recommend a delayed return for accurate drilling depth tolerances and for countersinking.

When the main valve is actuated, spindle feed and rotation commence. When the valve is released, the spindle returns to its start position and the motor's rotation ceases.

Working Pressure	6–7 bar
Air	Clean, dry and with oil mist (lubrication).
Options	Motor for air with no lubricator. Emergency break valve parallel to M2, which stops the unit and returns it to home position. Central silencer

BE 48 and BEG 48

Pneumatic limit switches

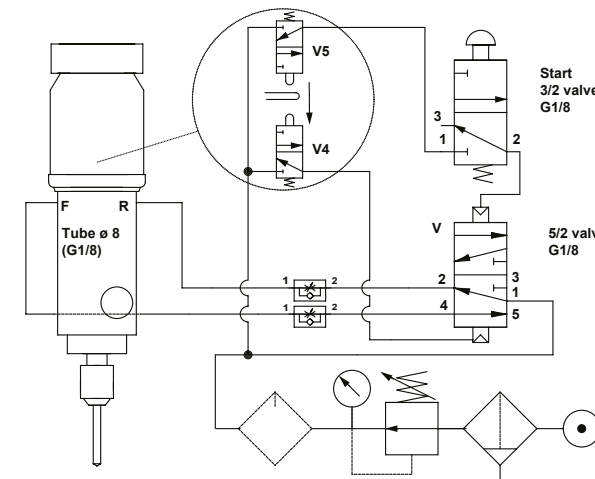

Electric limit switches or Linear transducer

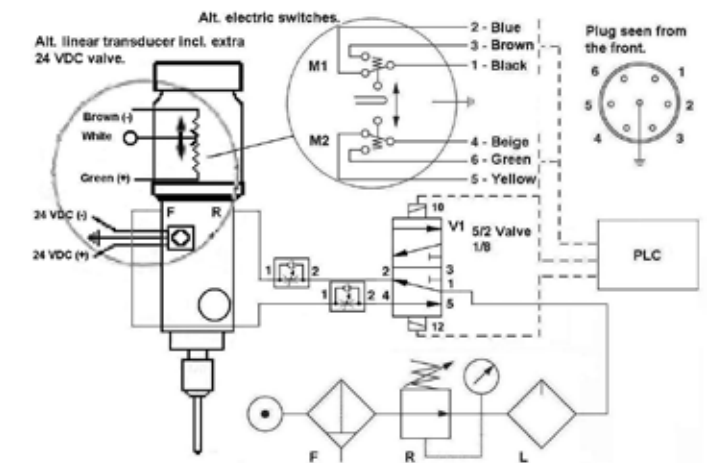

The max load for the switches at 220 V is 1A.

Linear transducer (optional) for full control of the stroke. Ideal for the control of automatic chip removal, multiwall drilling, tapping, reaming etc.

The limit switches comes with either 2 m hose (Pn) or 2 m cable (El).
We recommend a delayed return for accurate drilling depth tolerances and for countersinking.

Working Pressure	Max 8 bar
Air	Clean and dry. Lubrication is not necessary but increases the life span of the unit.
Options	Emergency break valve parallel to V4 (unit returns to home position, the spindle must be shut off electrically)
Motor	The electrical motors are 3-phase and designed to work with both 50 and 60 Hz. Connect the motor via an overload cut-out to provide protection against overloading. Standard units can be operated via frequency converters, normally in the speed range 30–150 %. When tapping with reversible motor you must add a pole reversal contactor to the system.

BE 55 and BEG 55

Control systems and electrical connections:

The signal comes from the limit sensors of the BE(G) 55 from the control system. There is one sensor for the home and one for the extracted position. The drilling or tapping cycle/depth is controlled by a linear sensor which enables you to set the rapid feed distance, max drilling depth, chip-removal cycle and/or multi-wall drilling function.

There are two control systems to choose from:

C1A where you handle sensor signals and control valves externally (the control system has push buttons to manually control the valves for fast approach and controlled feed). Typically used together with PLC or similar.

C5A is a logic control system with integrated functions for normal cycle, chip removal and multi wall operation integrated. You only need a switch (impulse max 0.5 s) to start the operation. A ready signal will indicate when the cycle is completed.

The C5A control system and valve coils are designed for 230 V 50 Hz or 110 V 50/60 Hz. The C1A control system is powered separately by 24 VDC. Both control systems are supplied with cables for connecting external controls.

Motors

The electrical motors are 3-phase and designed to work with both 50 and 60 Hz. Connect motor via an overload cut-out to provide protection against overloading. Standard units can be operated via frequency converters, normally in the speed range 30-150 %. Note: minimum motor speed with standard hydraulic gear pump is 500 rpm. When tapping with reversible motor you must add a pole reversal contactor to the system.

LS 11 and LS 22

Pneumatic limit switches

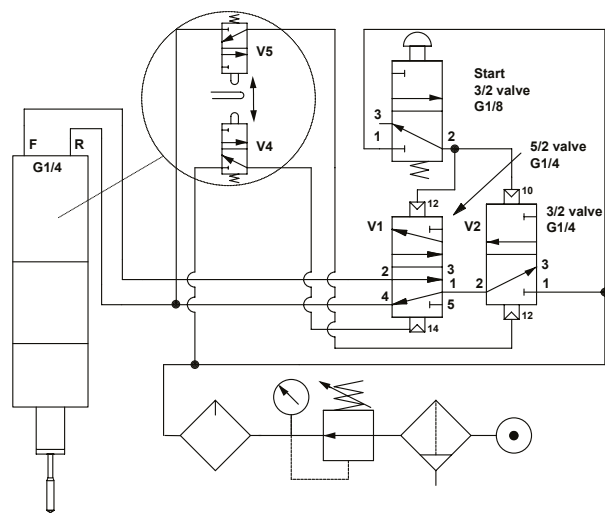

Electric limit switches

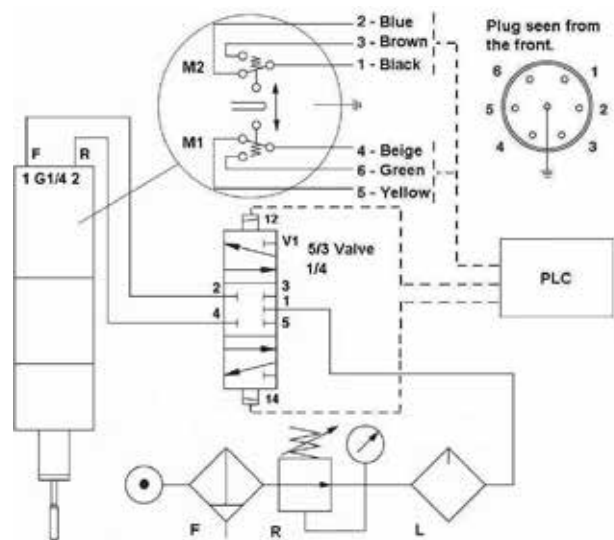

The max load for the switches at 220 V is 1A.

The limit switches come with either 1.2 m hose (Pn) or 1.2 m cable (El).

Working Pressure	6-7 bar
Air	Clean, dry and with oil mist (lubrication).
Options	Motor for air with no lubricator. Emergency break 3/2 button. Connection from main to port 14 on valve V1 (unit goes to home position)